



Pneumatic expansion shafts



Mechanical expansion shafts



Expansion couplings



Expansion chucks and adapters



Friction and knife shafts

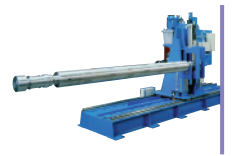

Shaft handling

Expansion chucks and adapters





Pneumatic expansion shafts



Mechanical expansion shafts



Expansion couplings



Expansion chucks and adapters



Friction and knife shafts



Shaft handling



		Page
4.1	Mechanically activated	
4.1.1	Mech. expansion chuck Series 831	4
4.1.2	Mech. expansion chuck Series 841	6
4.1.3	Mech. expansion chuck Series 834	8
4.2	Pneumatically activated	
4.2.1	Mech. expansion chuck Series 860/861	10
4.2.2	Mech. expansion chuck Series 811	12
4.3	Mech. adapter Series 900	14
4.4	Inquiry data sheet	16

We want you to be successful

The expansion units presented in this catalogue originate from the Vorwald Classic Programme and the winding technology products developed and marketed by Deublin USA and Germany. By virtue of their specific features these products have acquired a large market share in the field of rewinding and unwinding systems in the paper and film processing industry ranging from the smallest to the largest installations. The sheer breadth of products within the Neuenhauser-Vorwald range means that all areas of winding technology are now covered. Each product reflects the quality and experience of the manufacturing company behind it. Neuenhauser-Vorwald manufactures these products in European factories that are equipped with ultra-modern facilities and have been **certified according to DIN ISO 9001**. Our product quality and depth of experience ensures for all our customers economic utilisation of our expansion units.



Mechanical expansion chuck Series 831

with individual expansion lugs

The Vorwald expansion chucks of the Series 831 are suitable for rewinding and unwinding machines in which the required clamping force is applied by axial displacement of the expansion chuck support. In this process the core presses against the core stop collar of the expansion chuck and makes the expansion lugs expand centrally. The fixed centering nose prevents premature expansion of the expansion chuck.

Two types of expansion lugs are available to cover all requirements: Lengthwise grooved expansion lugs made of steel and expansion lugs with smooth surface made of polyurethane. The number and positioning of the expansion lugs in the so called mantle are determined by the customer requirements.

The lengthwise grooved and hardened surface of the steel expansion lugs permits the greatest possible torque transmission with cardboard cores. The smooth surface of the polyurethane expansion lugs permits this force transmission with steel, aluminium and plastic cores. All expansion lugs are equipped with a leg spring to ensure slide back into the mantle. This makes push-on and push-off of the

material cores easy. Expansion chucks with expansion lugs are available for cores with internal diameter in the range from 50 to 500 mm.

The functional principle is based on the inclined plane. The axial force pulls the expansion lugs outwards on the cone like on a wedge. The cone and the expansion lugs have the same bevel. This produces a radial movement from an axial movement. This arrangement provides the expansion chuck with a very large clamping force. A further very important advantage of this arrangement is the absolutely concentric clamping of the cores, because all expansion lugs expand uniformly to the same extent. This makes very high winding speeds achievable.

The mantles can be made of numerous materials with numerous different wall thicknesses, depending on the application intended by the customer. Based on the Vorwald standard, the expansion chucks are customised according to the modular design principle.

Sectional drawing of an expansion chuck, Series 831

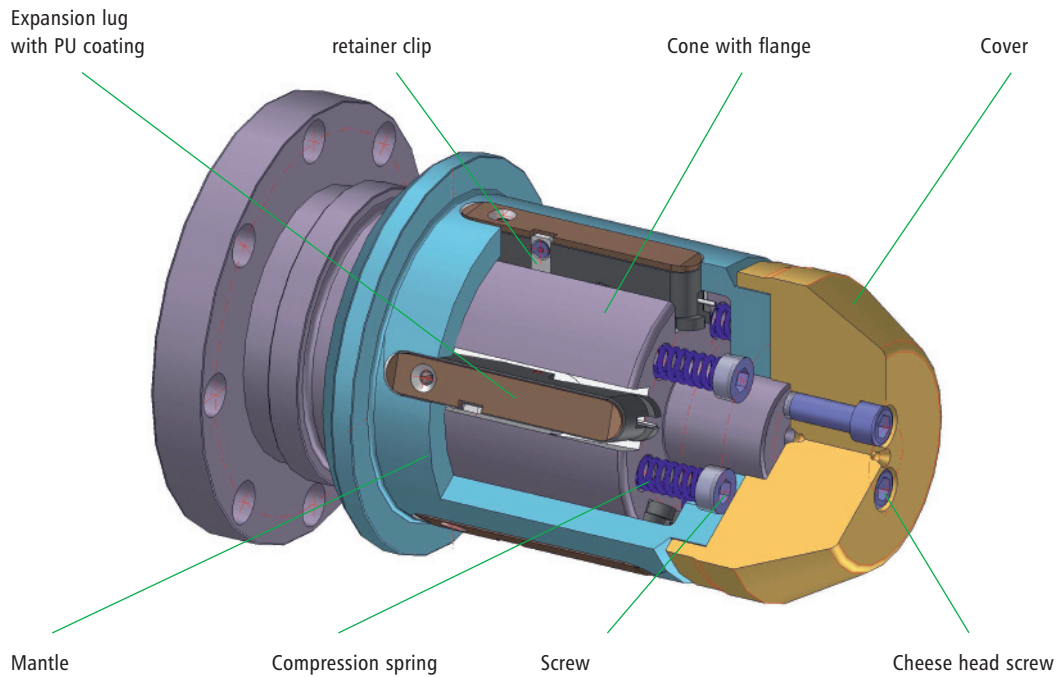

Options

- Various different expansion lug surfaces to match the respective core material
- Flange or bearing shaft according to customer specification
- Quick adaptation to various core diameters with adapters; see Section 4.3
- Special dimensions are possible on inquiry

Advantages

- + High torque transmission
- + True running tolerance ± 0.1 mm
- + Quick clamping and unclamping
- + No additional medium such as compressed air required for expanding

Available expansion chuck diameters ranging from 50 to 500 mm



Mechanical expansion chuck Series 841

with individual expansion lugs

The Vorwald expansion chucks of the Series 841 are suitable for shaftless rewinding and unwinding machines operating with medium torque values. The expansion of the expansion lugs takes place centrally.

Two different types of expansion lugs are available in order to cover all requirements: Lengthwise grooved expansion lugs made of steel and expansion lugs with smooth surface made of polyurethane. The number and positioning of the expansion lugs in the so called mantle are determined by the customer specifications. Alternatively expansion leaves made of aluminium or steel with and without surface refinement are available too.

The lengthwise grooved and hardened surface of the steel expansion lugs permits the greatest possible torque transmission with cardboard cores. The smooth surface of the polyurethane expansion lugs permits this force transmission with steel, aluminium and plastic cores. All expansion lugs are equipped with a leg spring to ensure slide back into the mantle. This makes push-on and push-off of the material

cores easy. Expansion chucks with expansion lugs or expansion leaves are available for cores with internal diameter in the range from 50 to 500 mm.

The functional principle is based on the inclined plane. Actuation of the radial tightening screw pushes the cone like a wedge under the expansion lugs, thus pressing them outwards. The cone and the expansion lugs have the same bevel. Thus a radial movement is produced from an axial movement. This arrangement provides the expansion chuck with a very large clamping force. A further very important advantage of this arrangement is the absolutely concentric clamping of the cores, because all expansion lugs expand uniformly to the same extent. This makes very high winding speeds achievable.

The mantles can be made of numerous different materials with numerous wall thicknesses, depending on the application envisaged by the customer. Based on the Vorwald standard, the expansion chucks are customised according to the modular design principle.

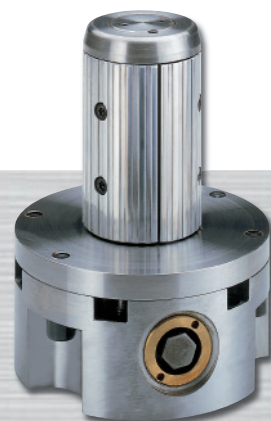

Sectional drawing of an expansion chuck , Series 841

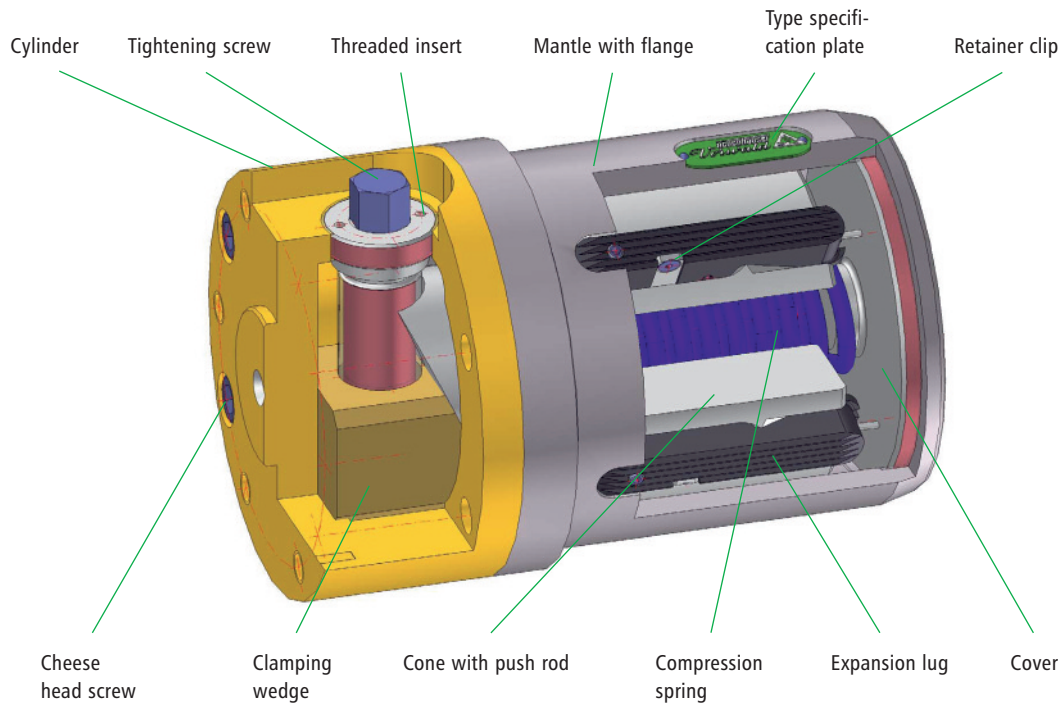

Options

- Various different expansion lug surfaces to match the respective core material
- Flange or bearing shaft according to customer specification
- Quick adaptation to various core diameters with adapters; see Section 4.3
- Special dimensions are possible on inquiry

Advantages

- + High torque transmission
- + True running tolerance ± 0.1 mm
- + Quick clamping and unclamping
- + No additional medium such as compressed air required for expanding

Available expansion chuck diameters ranging from 50 to 500 mm



Mechanical expansion chuck Series 834 ROLLMATIC®

with individual expansion leaves

The Vorwald expansion chucks of the Series 834 are suitable for unwinders without shafts. The expansion of the expansion leaves takes place centrally.

The roughened and hardened surface of the steel leaves permits the greatest possible torque transmission with cardboard, steel and plastic cores.

The functional principle is based on the inclined plane that lies in the winding direction. Through the existing web tension of the winding material a torque acts on the expansion chuck via the reel diameter. This torque makes cylindrical rollers inside the expansion chuck run up an inclined plane thereby pressing the expansion leaves outwards. An additional medium such as compressed air is not required for the activation.

The clamping force of the expansion chuck varies depending on the web height and the given braking torque of the unwinding machine. An important condition is that both expansion chucks must be braked and that a minimum torque of $0.05 \times$ the reel weight acts on the expansion chucks. A further very important advantage of this arrangement is the absolutely concentric clamping of the cores, because all expansion leaves expand uniformly to the same extent. This makes very high winding speeds achievable.

Based on the Vorwald standard the expansion chucks are customised according to the modular design principle.

Sectional drawing of an expansion chuck, Series 834

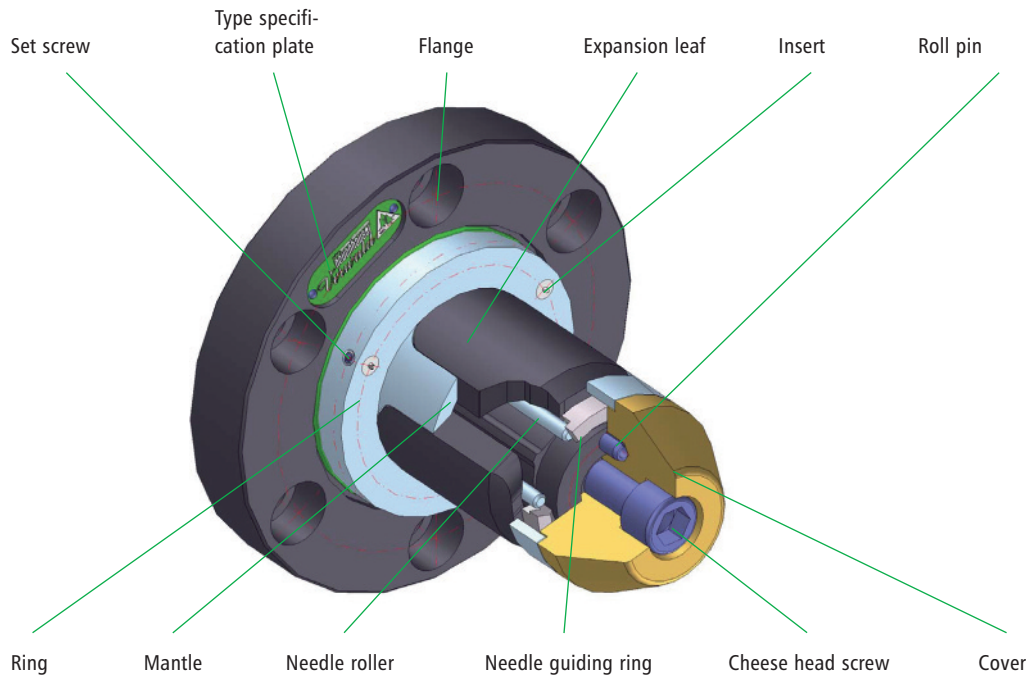

Options

- Flange or bearing shaft according to customer specification
- Special dimensions are possible on inquiry

Advantages

- + Transmission of highest torques
- + True running tolerance ± 0.1 mm
- + Quick clamping and unclamping
- + No additional medium such as compressed air required for expanding

Available expansion chuck diameters ranging from 68 to 500 mm



Mechanical expansion chuck Series 860/861

with individual expansion lugs or expansion leafs

The Vorwald expansion chucks of the Series 860 are standard expansion chucks with individual expansion lugs, that may be used in almost all winding processes.

The simple construction ensures long service life. Several different types of expansion lugs are available for covering all requirements: Lengthwise grooved expansion lugs made of steel and expansion lugs with smooth surface made of polyurethane or screwed versions with various surface profiles that are quickly interchangeable. The number and positioning of the expansion lugs in the mantle are determined by the customer requirements.

The numerous different surfaces of the hardened steel expansion lugs ensure greatest possible torque transmission into the various cores materials. All expansion lugs are equipped with a retracting system ensuring reliable contraction. This makes possible easy push-on and push-off of the cores. Expansion leafs are also available as alternative for the expansion lugs. Expansion chucks with expansion lugs or expansion leafs are available for cores with internal diameter in the range from 50 to 500 mm.

The functional principle is based on the inclined plane. By feeding compressed air into the pneumatic cylinder the pneumatic piston pushes the cone under the expansion lugs like a wedge. The cone and the expansion lugs have the same bevel. Thus a radial movement is produced from an axial movement. This arrangement provides the expansion chuck with a very large clamping force. The expansion chuck can be optionally equipped with a hydraulic booster (Series 861) that further increases the clamping force. A further very important advantage of this arrangement is the absolutely concentric clamping of the cores, because all expansion lugs expand uniformly to the same extent. This makes very fast winding speeds achievable.

The mantles of the expansion chucks can be made of numerous different materials with various wall thicknesses. Based on the Vorwald standard the expansion chucks are customised according to the modular design principle.

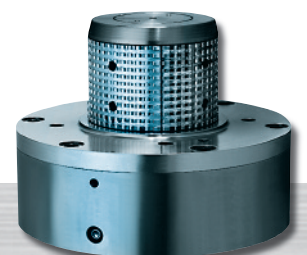

Sectional drawing of an expansion chuck, Series 860

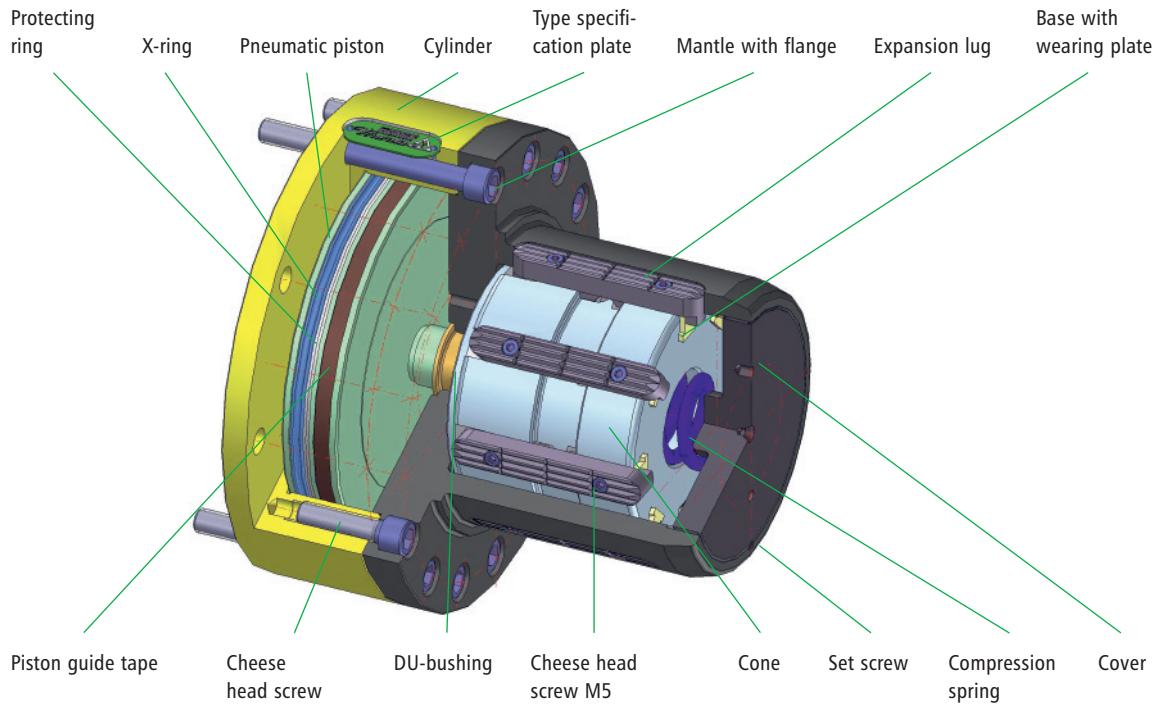

Options

- Flange or bearing shaft according to customer specification
- Available with and without booster
- Expansion lugs or expansion leaves with various surfaces
- Quick adaptation to various core diameters with adapters; see Section 4.3
- Special dimensions are possible on inquiry

Advantages

- + Transmission of highest torques
- + True running tolerance ± 0.1 mm
- + Absolutely centred clamping of the cores
- + Quick clamping and unclamping

Available expansion chuck diameters ranging from 50 to 500 mm



Mechanical expansion chuck

Series 811

with individual expansion lugs or expansion leafs

The Vorwald expansion chucks of the Series 811 are standard expansion chucks with individual expansion lugs, that can be utilised for almost all winding processes.

The very simple construction of the interface to the machine flange or to the existing cylinder permits quick change to other expansion chuck diameters.

Several different types of expansion lugs are available for covering all requirements: Lengthwise grooved expansion lugs made of steel and expansion lugs with smooth surface made of polyurethane or screwed versions with various surface profiles that are quickly interchangeable. The number and positions of the expansion lugs in the mantle are determined by the customer requirements.

The numerous different surfaces of the hardened steel expansion lugs ensure the greatest possible torque transmission into the various core materials. All expansion lugs are equipped with a retraction system ensuring reliable contraction. This makes push-on and push-off of the cores easy. Expansion leafs are also available as alternative to the expansion lugs. Expansion chucks with expansion lugs or expansion leafs are available for cores with internal diameter ranging from 50 to 500 mm.

The functional principle is based on the inclined plane. The clamping mechanism can be activated by an integrated pneumatic cylinder or by an external component mounted in the machine. Thereby the cone is pushed like a wedge under the expansion lugs. The cone and the expansion lugs have the same bevel. This produces a radial movement from an axial movement. This arrangement provides the expansion chuck with a very large clamping force. A further very important advantage is the absolutely concentric clamping of the cores, because all expansion lugs expand uniformly to the same extent. This makes very high winding speeds achievable.

The mantles of the expansion chucks can be made of numerous different materials with various wall thicknesses – depending on the application envisaged by the customer. Based on the Vorwald standard the expansion chucks are customised according to the modular design principle.

Sectional drawing of an expansion chuck, Series 811

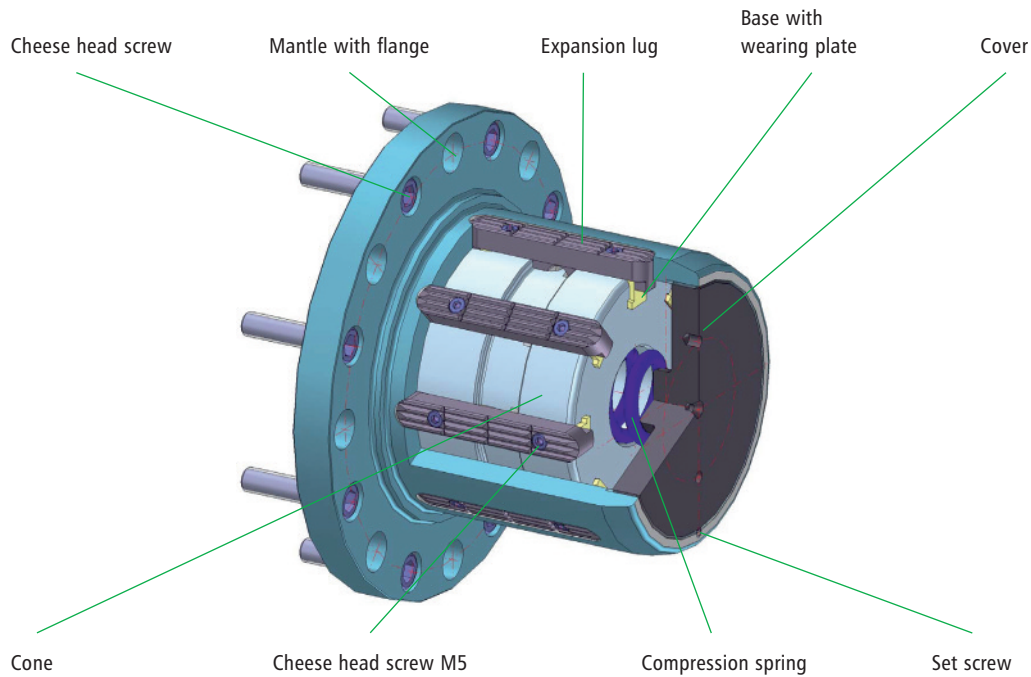

Options

- Expansion lug or expansion leaf with various surfaces
- Quick adaptation to various core diameters with adapters; see Section 4.3
- Special dimensions are possible on inquiry

Advantages

- + Transmission of highest torques
- + True running tolerance ± 0.1 mm
- + Quick clamping and unclamping
- + Absolutely centred clamping of the core
- + Utilisable with a very wide range of external clamping systems

Available expansion chuck diameters ranging from 50 to 500 mm



Mechanical adapter

Series 900

with individual expansion lugs or expansion leafs

The Vorwald adapters of the Series 900 with individual expansion lugs or expansion leafs are required when it is necessary to effect frequent change-overs between various core sizes.

Several different types of expansion lugs are available for covering all requirements: Lengthwise grooved expansion lugs made of steel and expansion lugs with smooth surface made of polyurethane or screwed versions with various different surface profiles that are quickly interchangeable.

The various different surfaces of the expansion lugs or expansion leafs ensure greatest possible torque transmission into the various different core materials. All expansion lugs and expansion leafs are equipped with a retraction system that ensures reliable contraction. This makes push-on and push-off of the cores easy. The adapters are available for cores with internal diameters up to 500 mm.

Activation takes place with the associated expansion chuck, i.e. the adapter is positioned by a parallel key, pushed onto an expansion chuck and secured by radial set screws against axial slip. When the carrier expansion chuck expands, the expansion lugs or expansion leafs of the adapter are pressed outwards too. A further very important advantage is the absolutely concentric clamping of the cores, because all expansion lugs expand uniformly to the same extent. This makes very high winding speeds achievable.

The mantles of the adapters can be made of numerous different materials with various wall thicknesses – depending on the intended application by the customer. Based on the Vorwald standard the adapters are customised according to the modular design principle.



Sectional drawing of an adapter, Series 900

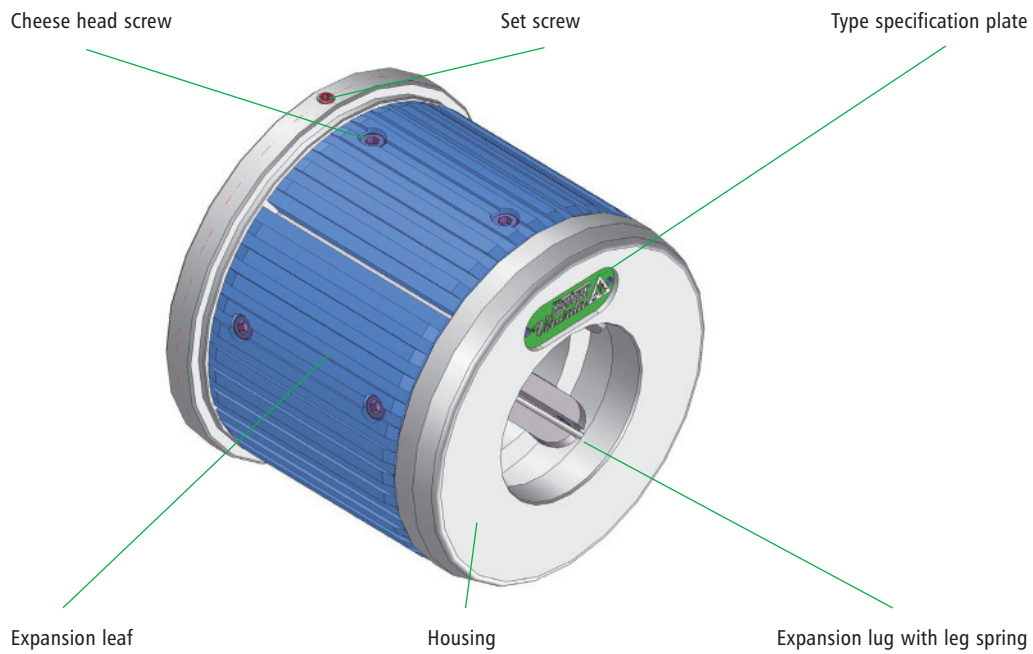

Options

- Expansion lug or expansion leafs with various different surfaces
- Quick adaptation to various different core diameters
- Special dimensions are possible on inquiry

Advantages

- + Transmission of highest torques
- + True running tolerance ± 0.1 mm
- + Quick clamping and unclamping with the existing expansion chuck
- + Absolutely centred clamping of the core

Available adapter diameters ranging from 98 to 500 mm



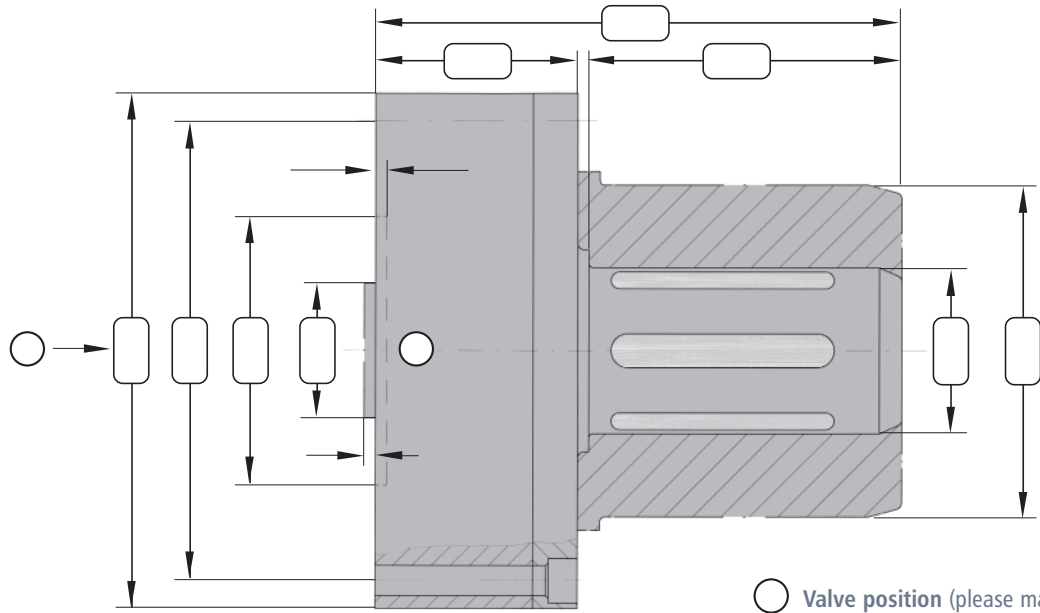

○ Valve position (please mark with a cross)

Core information for expansion chuck

Core internal diameter ±
 Core external diameter
 Core material

Core information for adapter

Core internal diameter ±
 Core external diameter
 Core material

- Unwind unit Centre drive unit
 Rewind unit Circumferential drive unit

Comments

.....

Technical requirements

Material
 Web speed (max.) m/min
 Web tension (max.) N;(N/cm)
 Working width (max.) mm
 Working width (min.) mm
 Total drive torque Nm
 Drive on one side on both sides
 Total braking torque (max.) Nm
 Brake on one side on both sides
 Emergency stop sec.
 Reel diameter mm
 Reel weight (max.) kg
 Reel weight (min.) kg
 Central expanding yes no

Representations in

Austria
Czech Republic
Denmark
Finland
France

Germany
Great Britain
Greece
Hungary
Iran

Israel
Macedonia
Netherlands
Norway
Poland

Portugal
Slovakian Republic
Slovenia/Croatia
South Africa
Spain

Sweden
Switzerland
Turkey
USA



Production plant in Neuenhaus

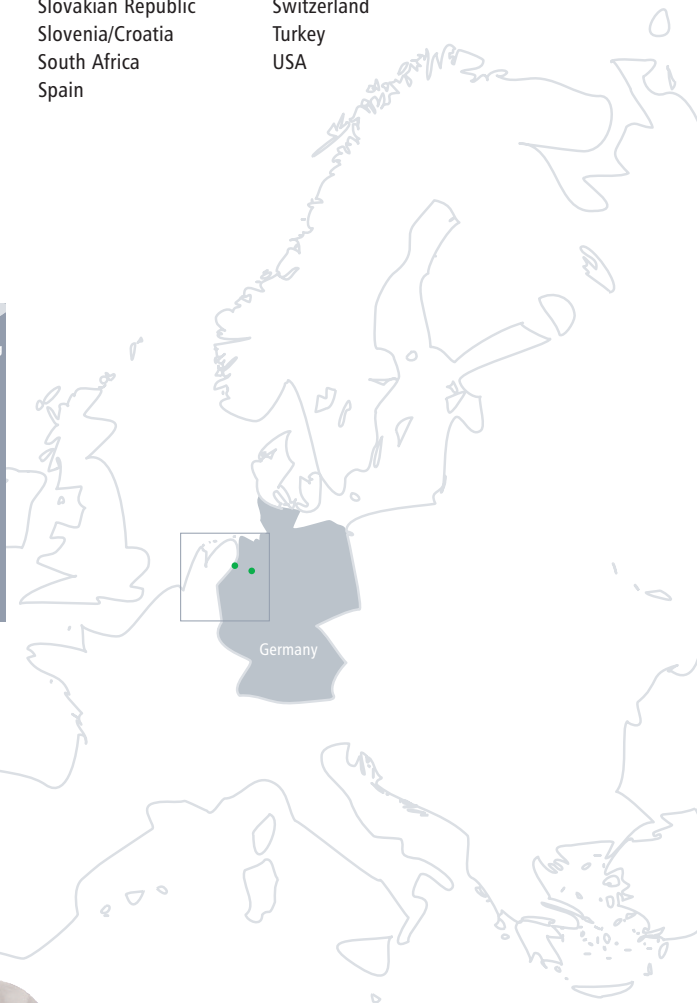

Neuenhauser Maschinenbau GmbH

Sales Department

Vorwald Expansion Units

Iburger Straße 225

D-49082 Osnabrück

Phone +49 (0) 541 / 5 05 46 - 0

Telefax +49 (0) 541 / 5 05 46 - 10

E-Mail neuenhauser@vorwald.de

Internet www.vorwald.de

Headquarters and service

Hans-Voshaar-Straße 5

D-49828 Neuenhaus

Phone +49 (0) 59 41 / 604 - 0

Telefax +49 (0) 59 41 / 604 - 206