

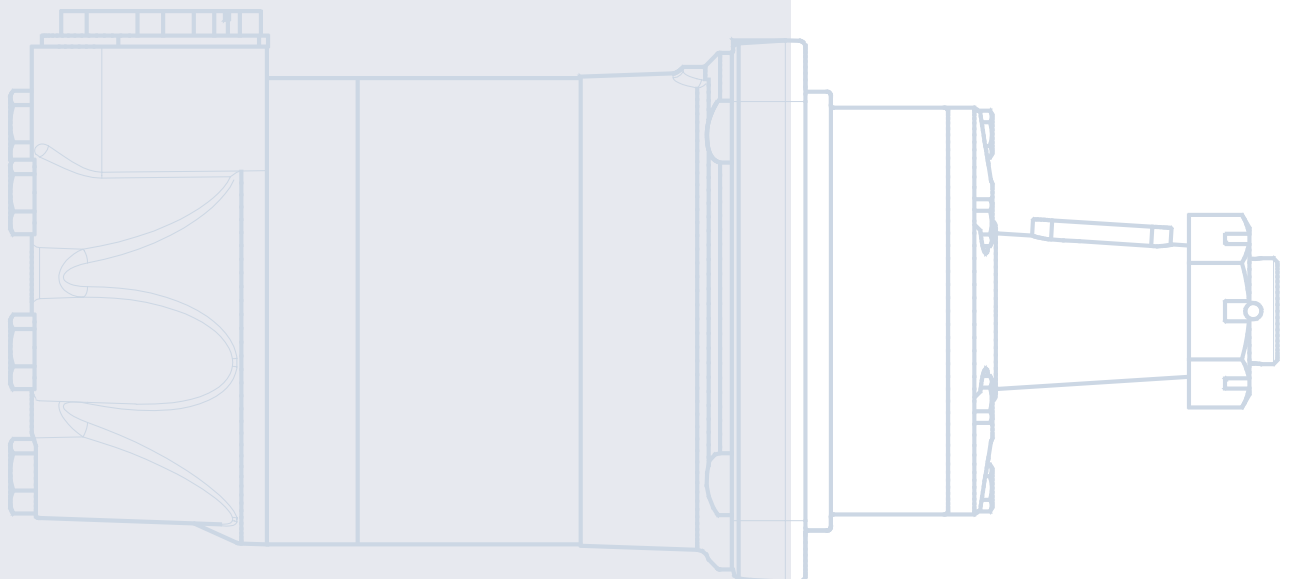

TMK, TMKW and  
TMK FL  
Orbital Motors

Technical  
Information

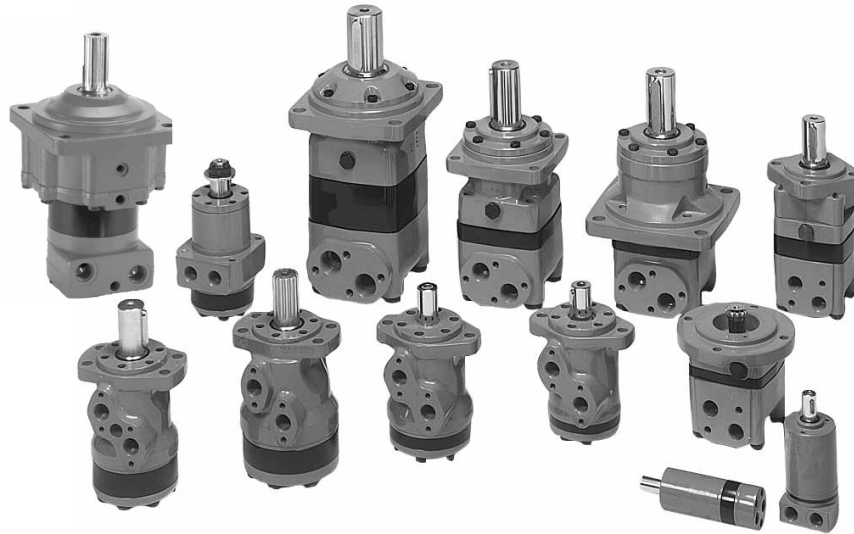

**A Wide Range of  
Orbital Motors**

F300 030

Sauer-Danfoss is a world leader within production of low speed orbital motors with high torque. We can offer more than 1600 different orbital motors, categorised in types, variants and sizes (incl. different shaft versions).

The motors vary in size (rated displacement) from 8 cm<sup>3</sup> [0.50 in<sup>3</sup>] to 800 cm<sup>3</sup> [48.9 in<sup>3</sup>] per revolution.

Speeds range up to approx. 2500 min<sup>-1</sup> (rpm) for the smallest type and up to approx. 600 min<sup>-1</sup> (rpm) for the largest type.

Maximum operating torques vary from 13 Nm [115 lbf·in] to 2700 Nm [24.000 lbf·in] (peak) and maximum outputs are from 2,0 kW [2,7 hp] to 70 kW [95 hp].

**Characteristic features:**

- Smooth running over the entire speed range
- Constant operating torque over a wide speed range
- High starting torque
- High return pressure without the use of drain line (High pressure shaft seal)
- High efficiency
- Long life under extreme operating conditions
- Robust and compact design
- High radial and axial bearing capacity
- For applications in both open and closed loop hydraulic systems
- Suitable for a wide variety of hydraulics fluids

© 2012 Sauer-Danfoss. All rights reserved. Printed in Europe  
Sauer-Danfoss accepts no responsibility for possible errors in catalogs, brochures and other printed material. Sauer-Danfoss reserves the right to alter its products without prior notice. This also applies to products already ordered provided that such alterations aren't in conflict with agreed specifications. All trademarks in this material are properties of their respective owners. Sauer-Danfoss and the Sauer-Danfoss logotype are trademarks of the Sauer-Danfoss Group.

Front cover illustrations: P300651.tif, P300652.tif, P330653.tif and F300654  
drawing: 151-1959 FA

**A Wide Range of  
Orbital Motors  
(continued)**

The programme is characterised by technical features appealing to a large number of applications and a part of the programme is characterised by motors that can be adapted to a given application. Adaptions comprise the following variants among others:

- Motors with corrosion resistant parts
- Wheel motors with recessed mounting flange
- OMP, OMR- motors with needle bearing
- OMR motor in low leakage version
- OMR motors in a super low leakage version
- Short motors without bearings
- Ultra short motors
- Motors with integrated positive holding brake
- Motors with integrated negative holding brake
- Motors with integrated flushing valve
- Motors with speed sensor
- Motors with tacho connection
- All motors are available with black finish paint

The Sauer-Danfoss orbital motors are used in the following application areas:

- Construction equipment
- Agricultural equipment
- Material handling & Lifting equipment
- Forestry equipment
- Lawn and turf equipment
- Special purpose
- Machine tools and stationary equipment
- Marine equipment

**Survey of literature with  
technical data on Sauer-  
Danfoss orbital motors**

Detailed data on all Sauer-Danfoss motors can be found in our motor catalogue, which is divided into 5 individual subcatalogues:

- General information on Sauer-Danfoss orbital motors: function, use, selection of hydraulic motor, hydraulic systems, etc.
- Technical data on small motors: OML and OMM
- Technical data on medium sized motors: OMP, OMR, OMH and OMEW
- Technical data on medium sized motors: DH and DS
- Technical data on large motors: OMS, OMT and OMV
- Technical data on large motors: TMK
- Technical data on large motors: TMT

A general survey brochure on Sauer-Danfoss orbital motors gives a quick motor reference based on power, torque, speed and capabilities.

<b>A Wide Range of Orbital Motors</b>	A wide range of orbital motors .....	2
<b>Contents</b>	Contents .....	4
<b>Data Survey</b>	Speed and torque .....	5
<b>Versions</b>	Versions.....	6
<b>Code Numbers</b>	Code Numbers .....	7
<b>Technical Data</b>	Technical Data .....	8
	Max. permissible shaft seal pressure .....	10
	Pressure drop in motor .....	10
	Oil flow in drain line .....	11
	Direction of shaft .....	11
	Function diagrams.....	14
	Shaft Versions.....	17
	Port Thread Versions .....	19
<b>Dimensions</b>	Dimensions.....	20
<b>Weight of Motors</b>	Weight of Motors.....	26

Speed and Torque

Max. speed

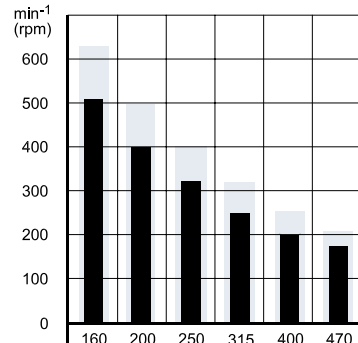

Max. torque

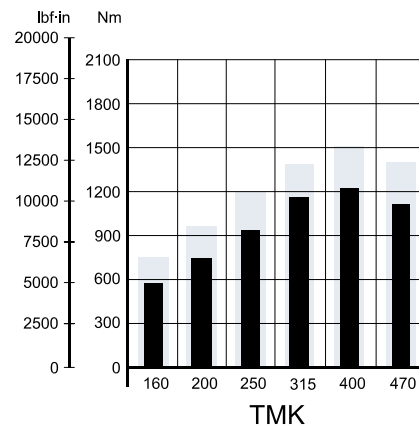

TMK

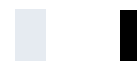

151-2053.10

Intermittent values

Continuous values

The bar diagrams above are useful for a quick selection of relevant motor size for the application. The final motor size can be determined by using the function diagram for each motor size.

- **TMK** can be found on pages 14 - 16.

The function diagrams are based on actual tests on a representative number of motors from our production. The diagrams apply to a return pressure between 5 and 10 bar [75 and 150 psi] when using mineral based hydraulic oil with a viscosity of 35 mm<sup>2</sup>/s [165 SUS] and a temperature of 50°C [120°F]. For further explanation concerning how to read and use the function diagrams, please consult the paragraph "Selection of motor size" in the technical information "General" DHMH.PK.100.G2.02 520L0232.

**Versions**

Mounting flange	Spigot diameter (front /rear end)	Bolt circle diameter (BC)	Shaft	Port size	European version	US version	Side port version	End port version	Standard shaft seal	Drain connection	Check valve	Main type designation
Magneto	Ø3.25 in	Ø 4.187 in	Cyl 1.25 in	1 1/16 - 12 UN		☉	☉		☉	Yes	Yes	TMK
Magneto	Ø 3.25 in	Ø 4.187 in	Spl. 1.25 in	1 1/16 - 12 UN		☉	☉		☉	Yes	Yes	TMK
Magneto	Ø 3.25 in	Ø 4.187 in	Tap. 1.25 in	1 1/16 - 12 UN		☉	☉		☉	Yes	Yes	TMK
SAE - C	Ø 5 in	Ø 6.375 in	Cyl 1.25 in	1 1/16 - 12 UN		☉	☉		☉	Yes	Yes	TMK
SAE - C	Ø 5 in	Ø 6.375 in	Spl. 1.25 in	1 1/16 - 12 UN		☉	☉		☉	Yes	Yes	TMK
SAE - C	Ø 5 in	Ø 6.375 in	Tap. 1.25 in	1 1/16 - 12 UN		☉	☉		☉	Yes	Yes	TMK
SAE - C	Ø 5 in	Ø 6.375 in	Tap. 1.5 in	1 1/16 - 12 UN		☉	☉		☉	Yes	Yes	TMK
SAE - C	Ø 5 in	Ø 6.375 in	Tap. 1.625 in	1 1/16 - 12 UN		☉	☉		☉	Yes	Yes	TMK
Wheel	Ø 4.25 in Ø 5 in	Ø 5.8 in	Tap. 1.5 in	1 1/16 - 12 UN		☉	☉		☉	Yes	No	TMKW
				7/8 - 14 UNF		☉		☉	☉	Yes	No	TMKW
Brake standard	Ø 5.5 in (only rear)	Ø 6.375 in	Tap. 1.5 in	1 1/16 - 12 UN		☉	☉		☉	Yes	No	TMK FL
				7/8 - 14 UNF		☉		☉	☉	Yes	No	TMK FL

Function diagram – see page : →

**Features available (options)**

Shaft options: Splined 1.5 in shaft  
 Cyl. 40 mm shaft (not brake version)

Port option: Side port G 3/4  
 End port G 1/2

Check valves  
 Flushing valves with different flushing flow

---

Motors are painted black

---

**Code Numbers**

Displacement (cm <sup>3</sup> )						Technical data - page	Dimensions - page
160	200	250	315	400	470		
→ 151F6060	151F6061	151F6062	151F6063	151F6064	151F6065	8	20
151F6050	151F6051	151F6052	151F6053	151F6054	151F6055	8	20
151F6070	151F6071	151F6072	151F6073	151F6074	151F6075	8	20
151F6130	151F6131	151F6132	151F6133	151F6134	151F6135	8	21
151F6120	151F6121	151F6122	151F6123	151F6124	151F6125	8	21
151F6140	151F6141	151F6142	151F6143	151F6144	151F6145	8	21
151F6090	151F6091	151F6092	151F6093	151F6094	151F6095	8	21
151F6080	151F6081	151F6082	151F6083	151F6084	151F6085	8	21
151F6010	151F6011	151F6012	151F6013	151F6014	151F6015	8	22
151F6030	151F6031	151F6032	151F6033	151F6034	151F6035	8	23
11008903	11008904	11008905	11008906	11008907	11008908	8	24
11008909	11008910	11008911	11008912	11008913	11008914	8	25
→ 14	14	15	15	16			

Type			TMK TMKW TMK FL	TMK TMKW TMK FL	TMK TMKW TMK FL	TMK TMKW TMK FL	TMK TMKW TMK FL	TMK TMKW TMK FL
<b>Motor size</b>			<b>160</b>	<b>200</b>	<b>250</b>	<b>315</b>	<b>400</b>	<b>470</b>
Geometric displacement	cm <sup>3</sup> [in <sup>3</sup> ]		158.0 [9.64]	201.5 [12.30]	252.2 [15.39]	315.3 [19.23]	397.2 [24.24]	471.1 [28.75]
Max. Speed	min <sup>-1</sup> [rpm]	cont.	505	400	320	255	200	170
		int. <sup>1)</sup>	630	500	400	315	250	210
Max. Torque*		cont.	570 [5045]	720 [6370]	910 [8055]	1050 [9295]	1070 [9470]	1080 [9560]
		int. <sup>1)</sup>	725 [6415]	920 [8140]	1070 [9470]	1310 [11595]	1400 [12390]	1350 [11950]
Max. Output	kW [hp]	cont.	22.0 [29.5]	22.0 [29.5]	21.0 [28]	20.0 [27]	17.5 [23.5]	13.0 [17.4]
		int. <sup>1)</sup>	27.0 [36]	27.0 [36]	25.0 [33.5]	23.5 [31.5]	22.0 [29.5]	17.0 [22.8]
Max. pressure drop *	bar [psi]	cont.	250 [3625]	250 [3625]	250 [3625]	250 [3625]	200 [2900]	160 [2320]
		int. <sup>1)</sup>	325 [4715]	325 [4715]	300 [4350]	300 [4350]	250 [3625]	200 [2900]
Max. oil flow	l/min [US gal/min]	cont.	80 [21.1]	80 [21.1]	80 [21.1]	80 [21.1]	80 [21.1]	80 [21.1]
		int. <sup>1)</sup>	100 [26.4]	100 [26.4]	100 [26.4]	100 [26.4]	100 [26.4]	100 [26.4]
Max. starting pressure with unloaded shaft	bar [psi]		8 [100]	8 [100]	7 [100]	7 [100]	7 [100]	7 [100]
Min. starting torque		at max. press. drop cont.: N·m [lbf·in]	430 [3805]	540 [4780]	680 [6020]	790 [6990]	800 [7080]	830 [7350]
		at max. press. drop int. <sup>1)</sup> : N·m [lbf·in]	545 [4825]	690 [6105]	800 [7080]	985 [8720]	1050 [9290]	1050 [9290]

Type		Max, inlet pressure		Max. return pressure with drain line
TMK 160 - 470	bar [psi] cont.	250 [3625]	bar [psi] cont.	140 [2030]
	bar [psi] max.	350 [5075]	bar [psi] int. <sup>1)</sup>	175 [2540]
			bar [psi] peak <sup>2)</sup>	210 [3045]

*Max. torque for shaft type	Tap. 1.25 in	Splined 1.25 in	Cyl. 1.25 in
N·m [lbf·in]	900 [8000]	900 [8000]	900 [8000]

Max. values apply for applications where there is no external radial load. If radial load is present, please contact Sauer-Danfoss for evaluation.

<sup>1)</sup> Intermittent operation: the permissible values may occur for max. 10% of every minute

<sup>2)</sup> Peak load: the permissible values may occur for max. 1% of every minute.

For max. permissible combination of flow and pressure, see function diagram for actual motor.



**Technical Data for  
 Parking Brake Motor  
 TMK FL**

Technical data for brake motor TMK FL		
Holding torque <sup>1)</sup>	Nm [lbf.in]	1050 [9295]
Min. release pressure <sup>2)</sup>	bar [psi]	15 [215]
Max. pressure in drain/brake line	bar [psi]	30 [435]

<sup>1)</sup> This brake is to be used only as a passive parking brake. It may not be used for dynamic braking.

When release pressure<sup>2)</sup> is greater than zero, the holding torque depends inversely proportional on the actual release pressure.

At 0 bar - holding torque = 1050 Nm [9295 lbf.in]  
 At 15 bar [215 psi] or more - holding torque = 0 Nm

<sup>2)</sup> The release pressure is the difference between the pressure in the drain/brake release line and the pressure in the vent line. The vent port must always be connected to tank.

The brake will be fully released at 15 bar [215 psi].

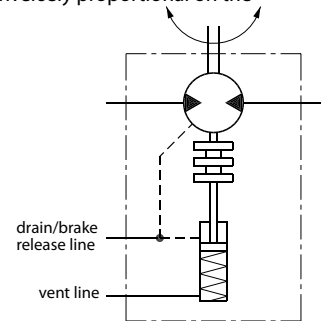

151-2009.11

**Schematic Diagram**

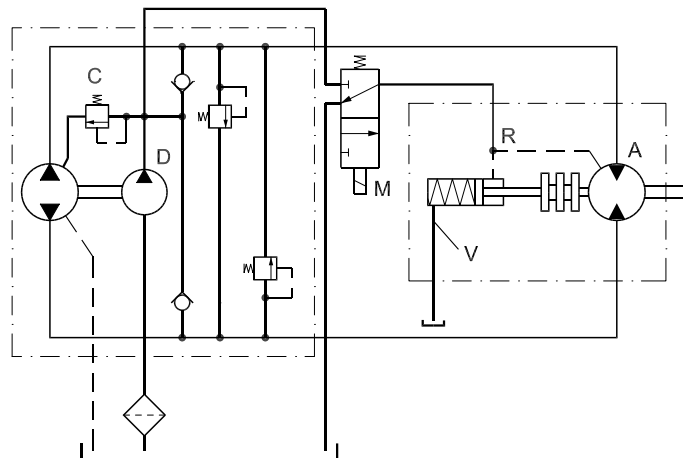

151-2018.13

The drain/release port on the TMK FL motor must never remain plugged or be connected to the system A or B pressures, since the brake is a low pressure device. A common solution for controlling the brake is to use a two position valve to connect the drain port to hydrostatic charge pressure (brake released), or to reservoir pressure (brake holding). The vent port must always be connected to tank. See the above schematic for details.

- A: Motor
- C: Charge pressure relief valve (setting min 15 bar [215 psi])
- D: Charge pump
- M: Brake release valve
- R: Drain and brake release port
- V: Vent line

**Max. Permissible Shaft Seal Pressure**

**TMK, TMKW and TMK FL with use of drain connection**  
 The shaft seal pressure equals the pressure in the drain line.

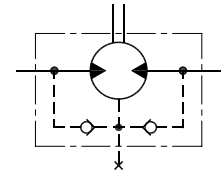

151-320.10

**TMK with check valves and without use of drain connection:**  
 The pressure on the shaft seal never exceeds the pressure in the return line.

**TMKW / TMK FL without check valves and without use of drain connection:**  
 The shaft seal pressure equals the average of input pressure and return pressure.

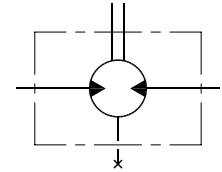

151-1855.10

TMK FL must always have a drainline.

*Max. pressure on shaft seal*

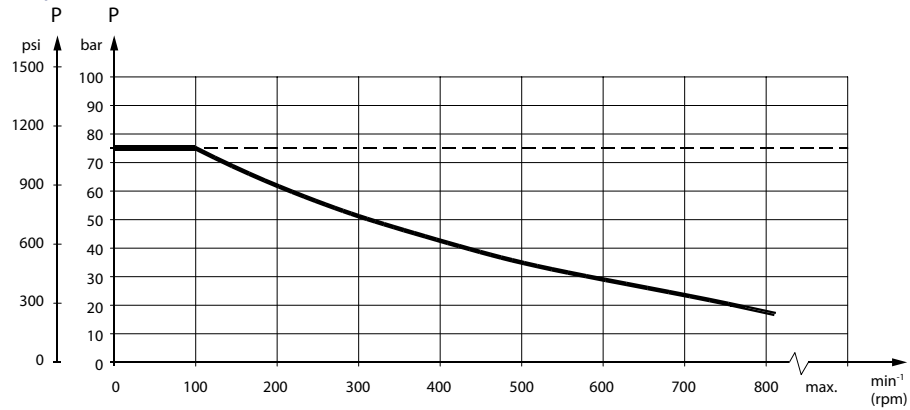

151-1674.10

**Pressure Drop in Motor**

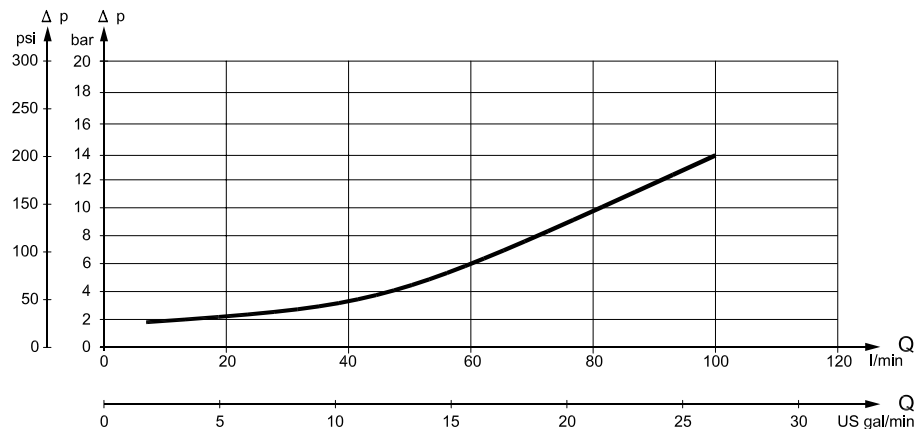

151-1957.11

The curve applies to an unloaded motor shaft and an oil viscosity of 35 mm<sup>2</sup>/s (165 SUS)

**Oil Flow in Drain Line**

The table below shows the max. oil flow in the drain line at a return pressure less than 5-10 bar [75-150 psi].

Pressure drop bar [psi]	Viscosity mm <sup>2</sup> /s [SUS]	Oil flow in drain line l/min [US gal/min]
160 [2320]	20 [100]	1.7 [0.45]
	35 [165]	1.2 [0.32]
325 [4713]	20 [100]	3.5 [0.92]
	35 [165]	2.5 [0.66]

**Direction of Shaft Rotation**

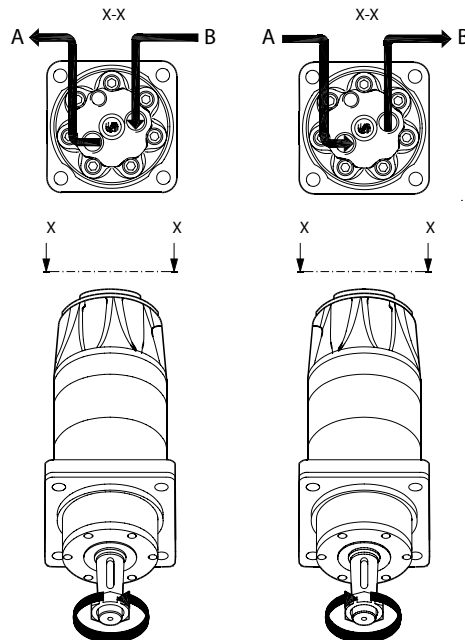

151-2008.11

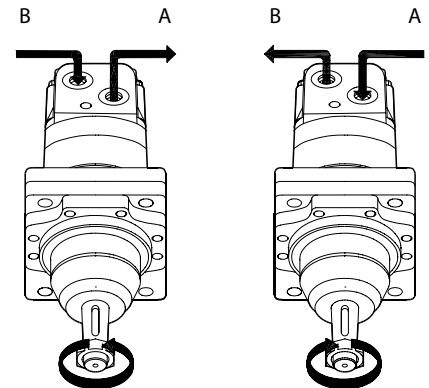

151-2006.11

**Permissible Shaft Load  
 for TMKW**

**Mounting flange:**  
 Magneto, SAE-C

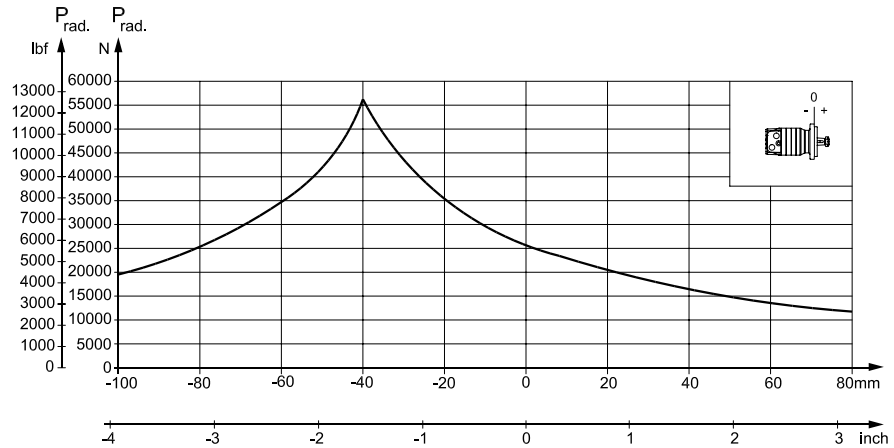

151-2059.10

**Mounting flange:**  
 Wheel

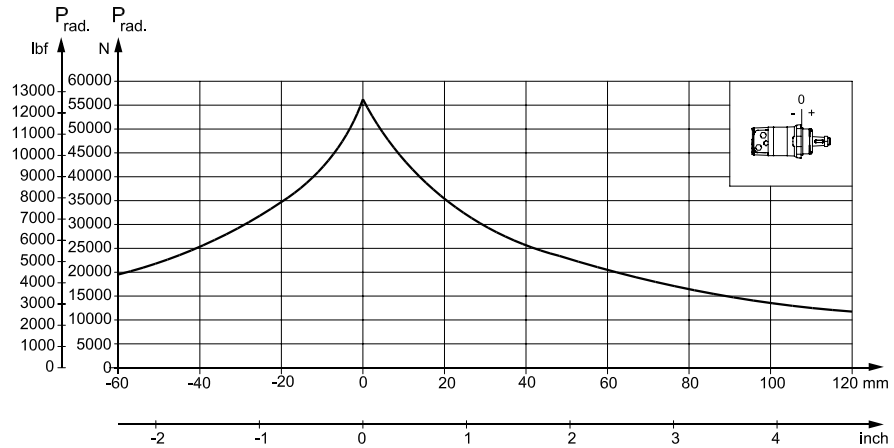

151-1955.10

**Permissible radial shaft load**

The output shaft runs in tapered roller bearings that permit high axial and radial forces.

The permissible radial load on the shaft is shown for an axial load of 0 N as a function of the distance from the mounting flange to the point of load application.

The curve is based on  $B_{10}$  Bearing life (2000 hours or 12 000 000 shaft revolutions at  $100 \text{ min}^{-1}$ ) at rated output torque, when mineral-based hydraulic oil with a sufficient content of anti-wear additives, is used.

**Permissible Shaft Load  
 for TMK FL**

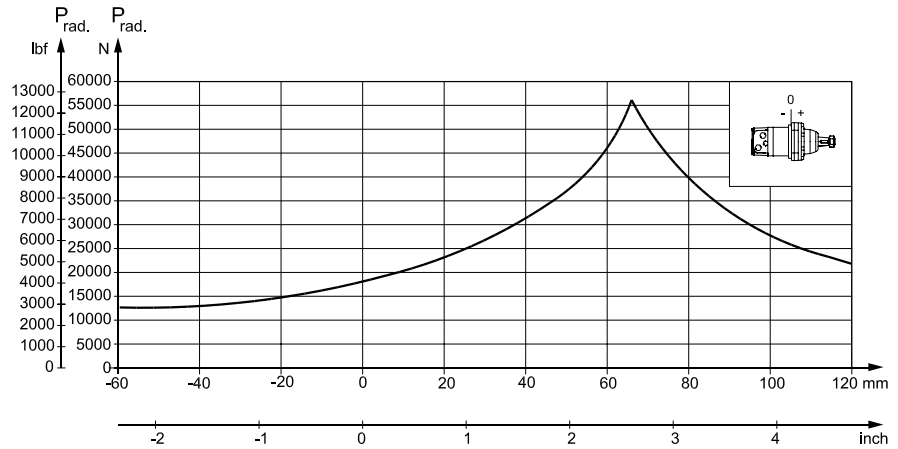

151-1956.10

**Permissible radial shaft load**

The output shaft runs in tapered roller bearings that permit high axial and radial forces.

The permissible radial load on the shaft is shown for an axial load of 0 N as a function of the distance from the mounting flange to the point of load application.

The curve is based on  $B_{10}$  Bearing life (2000 hours or 12 000 000 shaft revolutions at  $100 \text{ min}^{-1}$ ) at rated output torque, when mineral-based hydraulic oil with a sufficient content of anti-wear additives, is used.

Function Diagrams

TMK 160

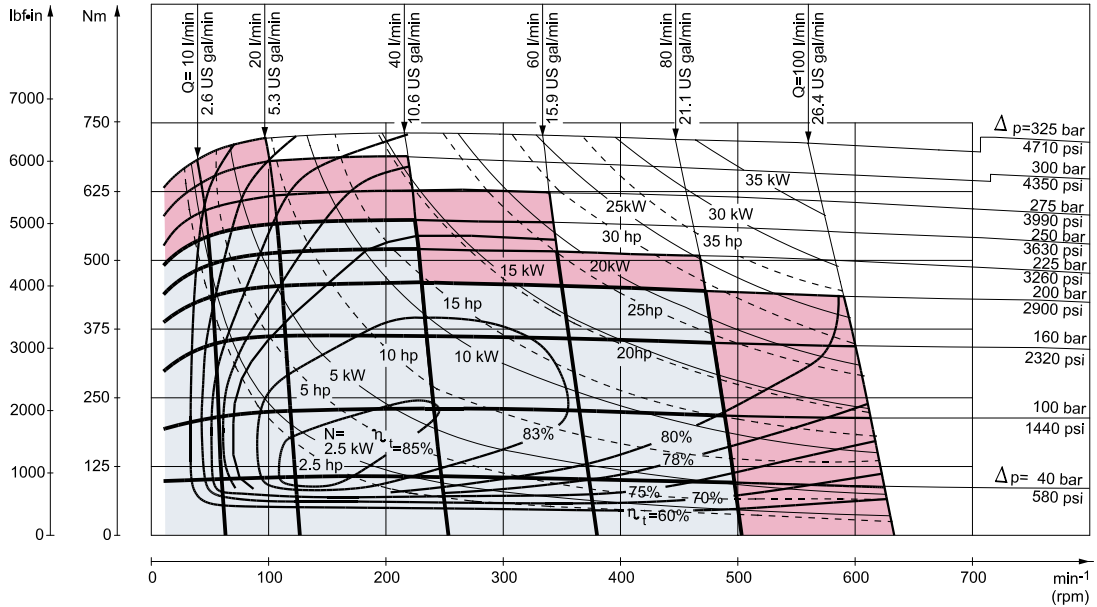

151-2013.10

TMK 200

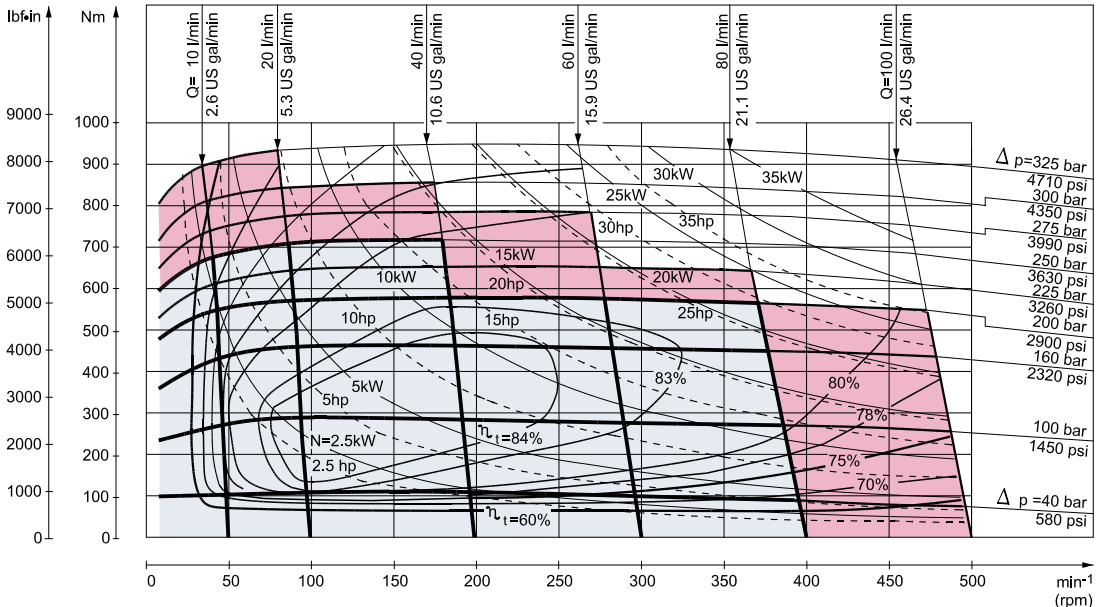

151-2014.10

Explanation of function diagram use, basis and conditions can be found on page 5.

- Continuous range
- Intermittent range (max. 10% operation every minute)

Intermittent pressure drop and oil flow must not occur simultaneously.

Function Diagrams  
 (continued)

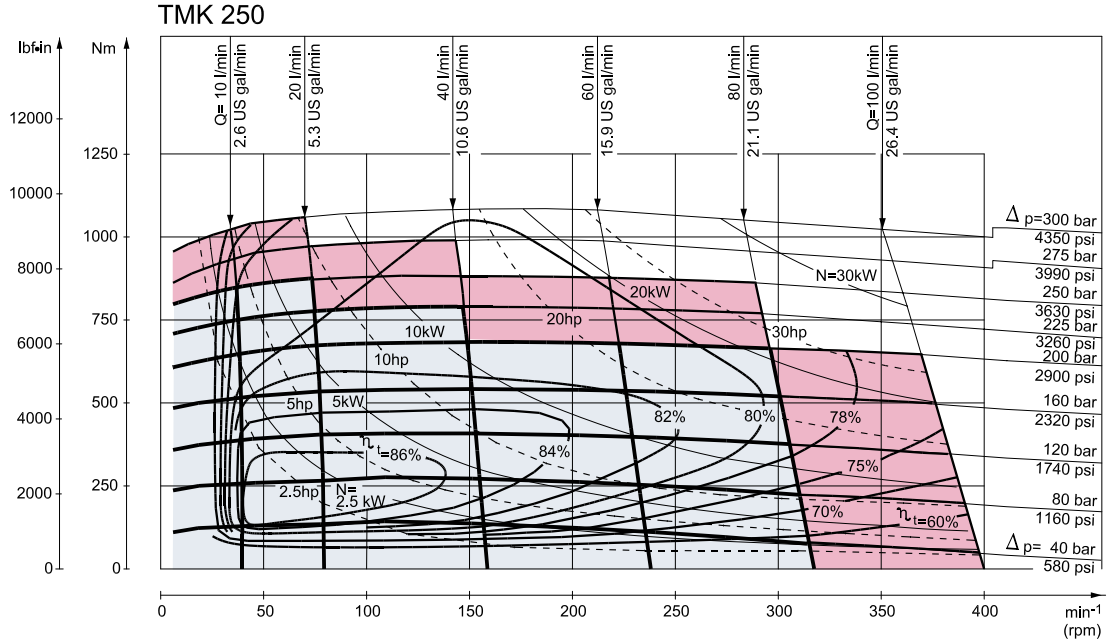

151-2015.10

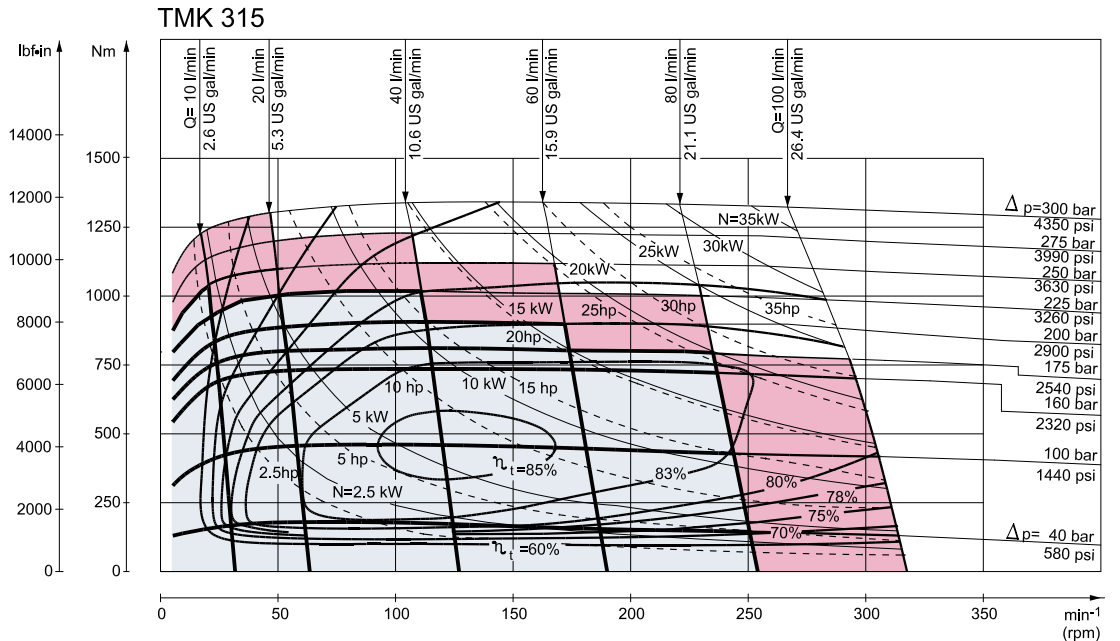

151-2016.10

Explanation of function diagram use, basis and conditions can be found on page 5.

- Continuous range
- Intermittent range (max. 10% operation every minute)

Intermittent pressure drop and oil flow must not occur simultaneously.

Function Diagrams  
 (continued)

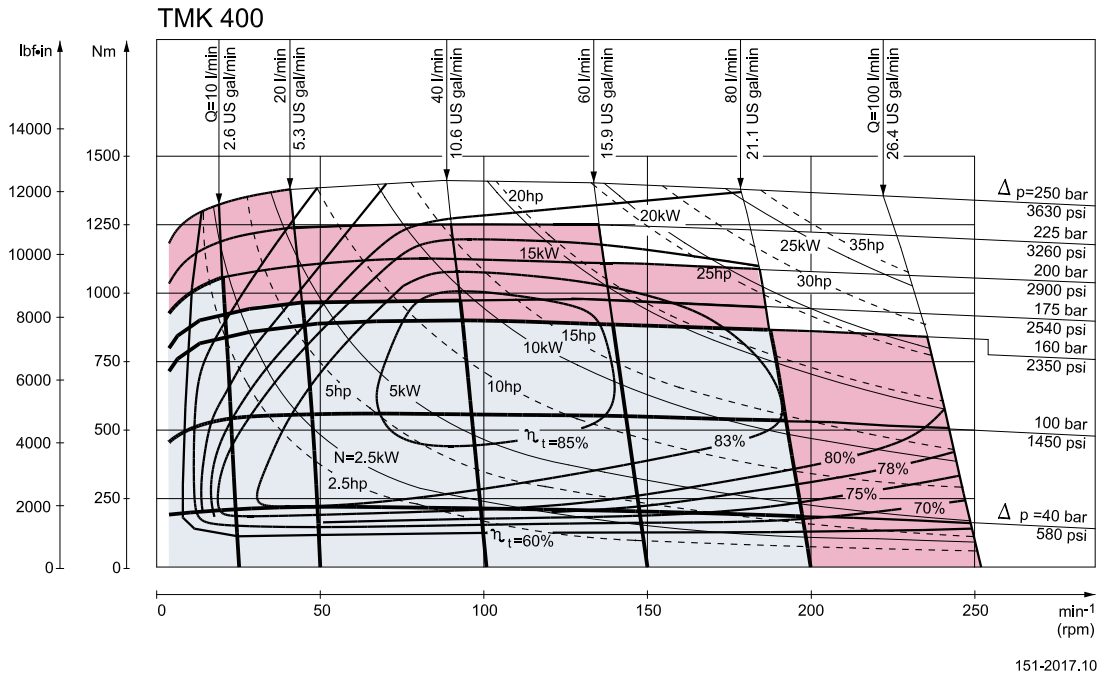

151-2017.10

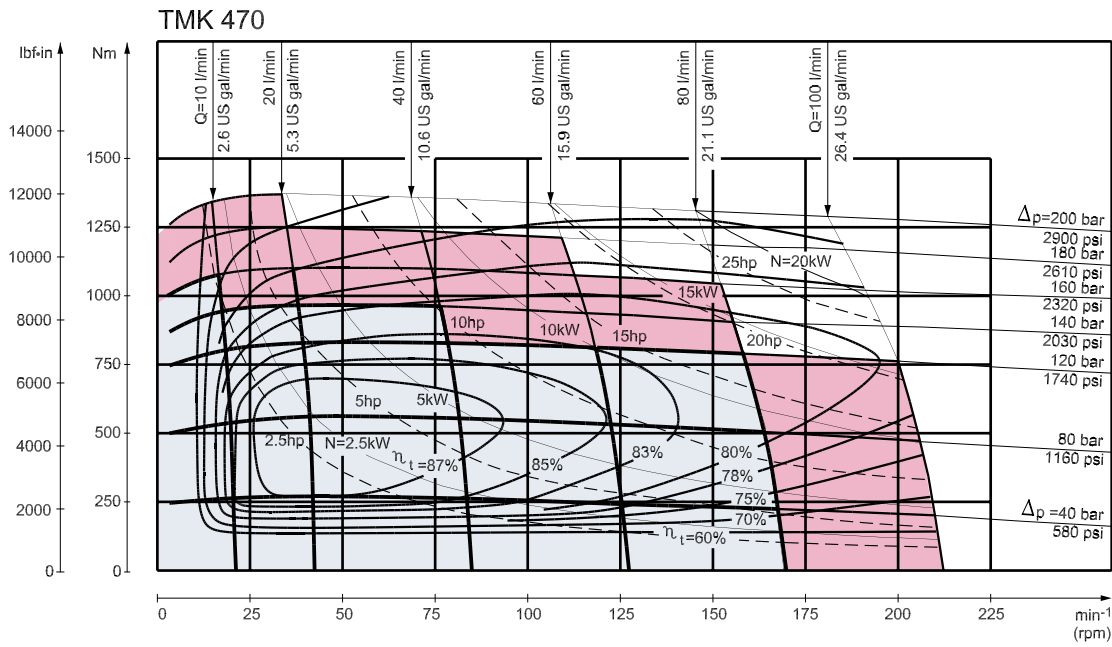

151-2142.10

Explanation of function diagram use, basis and conditions can be found on page 5.

- Continuous range
- Intermittent range (max. 10% operation every minute)

Intermittent pressure drop and oil flow must not occur simultaneously.



**Shaft Versions**

- A: Cylindrical shaft 1.25 in
- F: Parallel key  
 5/16 x 5/16 x 1 1/4 in  
 SAE J744

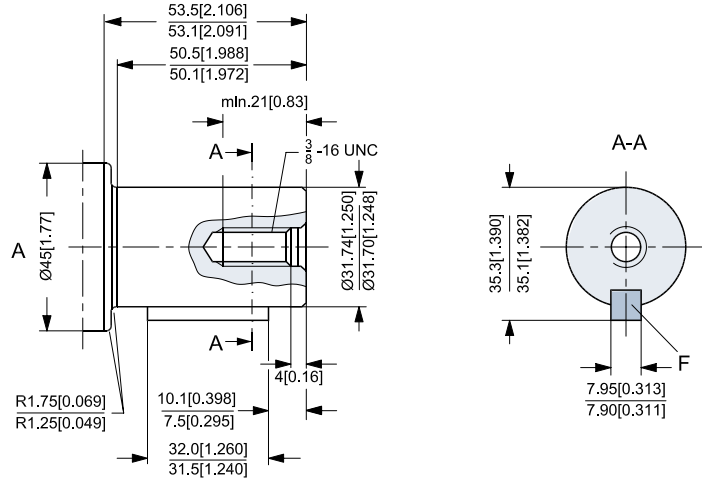

- B: Involute splined shaft  
 ANS B92.1 - 1970 standard  
 Flat root side fit  
 Pitch 12/24  
 Teeth 14  
 Major diameter: 1.25 in  
 Pressure angle 30°

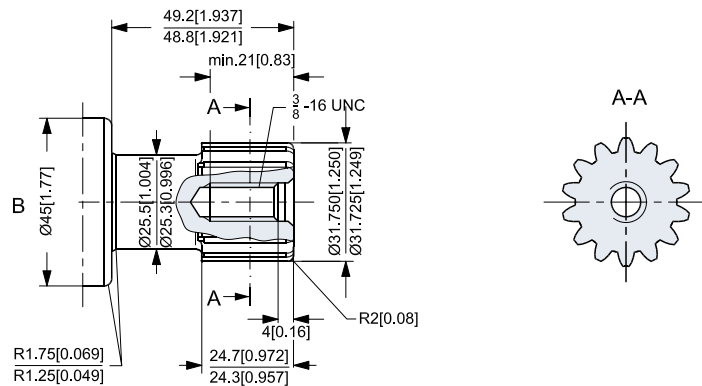

- C: Tapered shaft 1.25 in
- G: Cone 1 : 8  
 SAE J501
- H: 1 - 20 UNEF  
 Across flats: 1 7/16 in  
 Tightening torque:  
 450 ± 10 N·m  
 [3980 ± 85 lbf·in]
- I: Parallel key  
 5/16 x 5/16 x 3/4 in  
 SAE J501

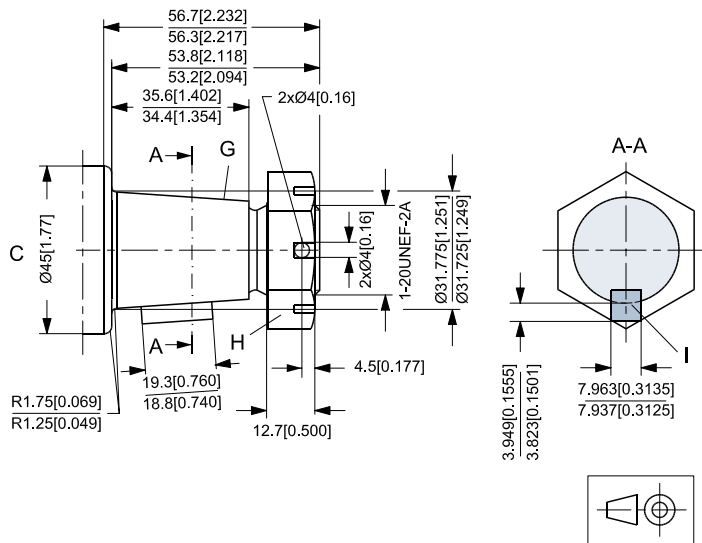

151-2057.10

- D: Tapered shaft 1.5 in
- J: Cone 1 : 8  
SAE J501
- K: 1 - 20 UNEF  
Across flats: 1 7/16 in  
Tightening torque:  
450 ± 10 N·m  
[3980 ± 85 lbf·in]
- L: Parallel key  
3/8 x 3/8 x 1 in  
B.S. 46

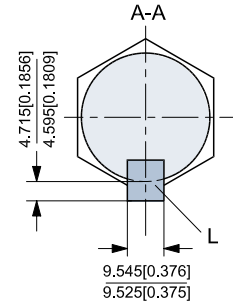
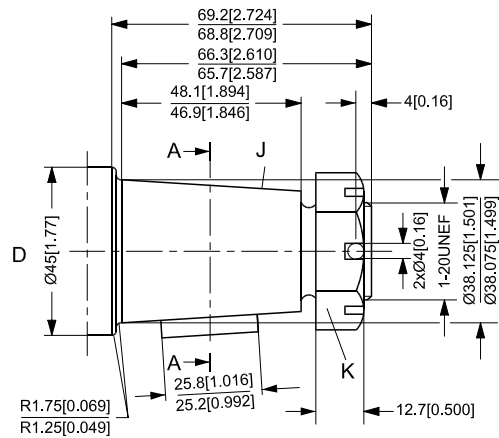

- E: Tapered shaft 1.625 in
- M: Cone 1 : 8  
SAE J501
- N: 1 1/4- 18 UNEF  
Across flats: 2 3/16 in  
Tightening torque:  
500 ± 10 N·m  
[4425 ± 85 lbf·in]
- O: Parallel key  
7/16 x 7/16 x 1 1/4 in  
B.S. 46

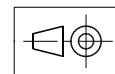
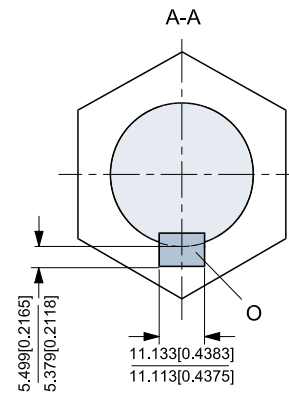
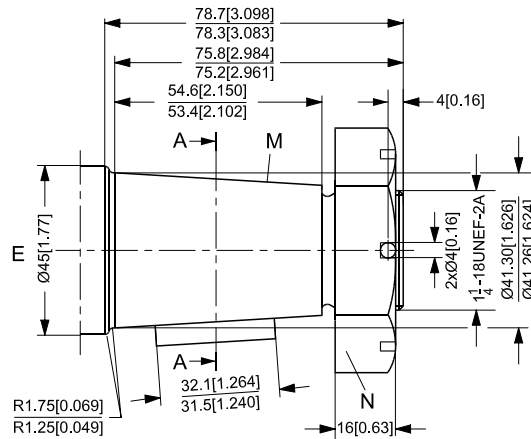

151-2058.10

Port Thread Versions

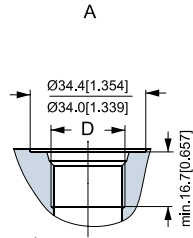

A: UNF Main port  
 D: 7/8 - 14 UNF  
 o-ring boss port

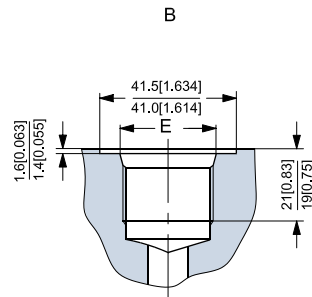

B: UN Main port  
 E: 1 1/16 - 12 UN  
 o-ring boss port

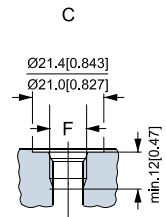

C: UNF Drain/release port  
 F: 7/16 - 20 UNF  
 o-ring boss port

**Dimensions**

*TMK with Magneto flange*

Type	mm L <sub>1</sub> [in]	mm L <sub>2</sub> [in]	mm L <sub>3</sub> [in]	mm L <sub>4</sub> [in]
TMK 160	204.6 [8.06]	179.6 [7.07]	160.8 [6.33]	151.4 [5.96]
TMK 200	210.6 [8.29]	185.6 [7.31]	166.8 [6.57]	157.4 [6.20]
TMK 250	217.6 [8.57]	192.6 [7.58]	176.8 [6.84]	164.4 [6.47]
TMK 315	226.3 [8.91]	201.3 [7.93]	182.5 [7.19]	173.1 [6.81]
TMK 400	237.6 [9.35]	212.6 [8.37]	193.8 [7.63]	184.4 [7.26]
TMK 470	247.8 [9.76]	222.8 [8.77]	204.0 [8.03]	194.6 [7.66]

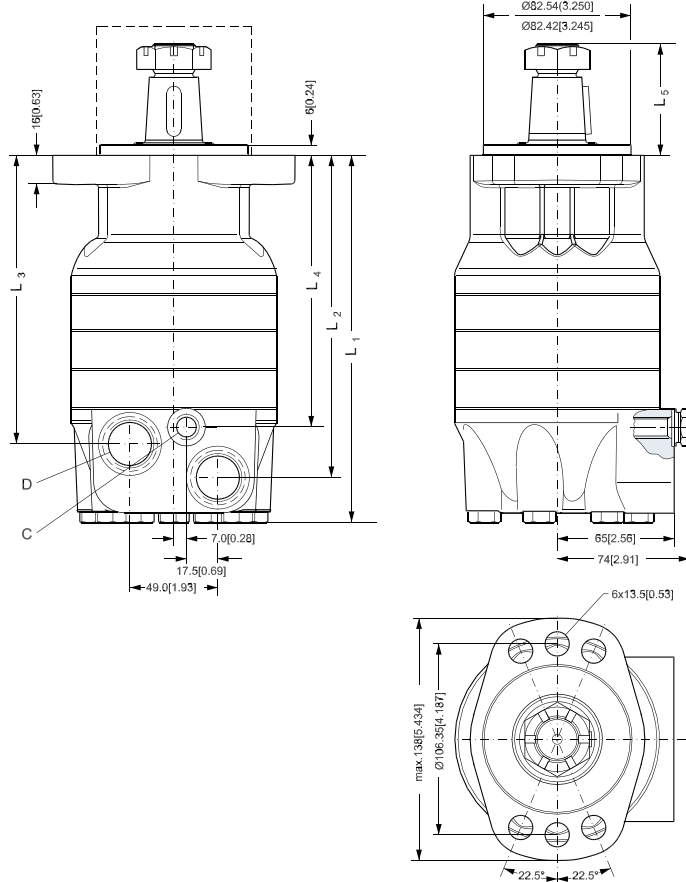

C: Drain connection 7/16 - 20 UNF

D: 2 x 1 1/16 - 12 UN

Output shaft	L <sub>s</sub>	
	mm	[in]
Cyl. 1.25 in	58.8	[2.31]
Spl. 1.25 in	56.0	[2.20]
Tap. 1.25 in	62.0	[2.44]

-----Not Painted

The stated dimensions are without paint



151-2055.11

**Dimensions**

*TMK with SAE-C flange*

Type	L <sub>1</sub> mm [in]	L <sub>2</sub> mm [in]	L <sub>3</sub> mm [in]	L <sub>4</sub> mm [in]
TMK 160	204.5 [8.05]	179.4 [7.06]	160.7 [6.33]	151.3 [5.96]
TMK 200	210.5 [8.29]	185.4 [7.30]	166.7 [6.56]	157.3 [6.19]
TMK 250	217.5 [8.56]	192.4 [7.57]	173.7 [6.84]	164.3 [6.47]
TMK 315	226.2 [8.91]	201.1 [7.92]	182.4 [7.18]	173.0 [6.81]
TMK 400	237.5 [9.35]	212.4 [8.36]	193.7 [7.63]	184.3 [7.26]
TMK 470	247.7 [9.75]	222.6 [8.76]	203.9 [8.03]	194.5 [7.66]

C: Drain connection 7/16 - 20 UNF  
 D: 2 x 1 1/16 - 12 UN

Output shaft	L <sub>s</sub>	
	mm	[in]
Cyl. 1.25 in	59.0	[2.32]
Spl. 1.25 in	56.3	[2.22]
Tap. 1.25 in	62.2	[2.45]
Tap. 1.5 in	74.8	[2.94]
Tap. 1.625 in	84.3	[3.32]

-----Not Painted

The stated dimensions are without paint

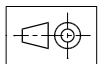
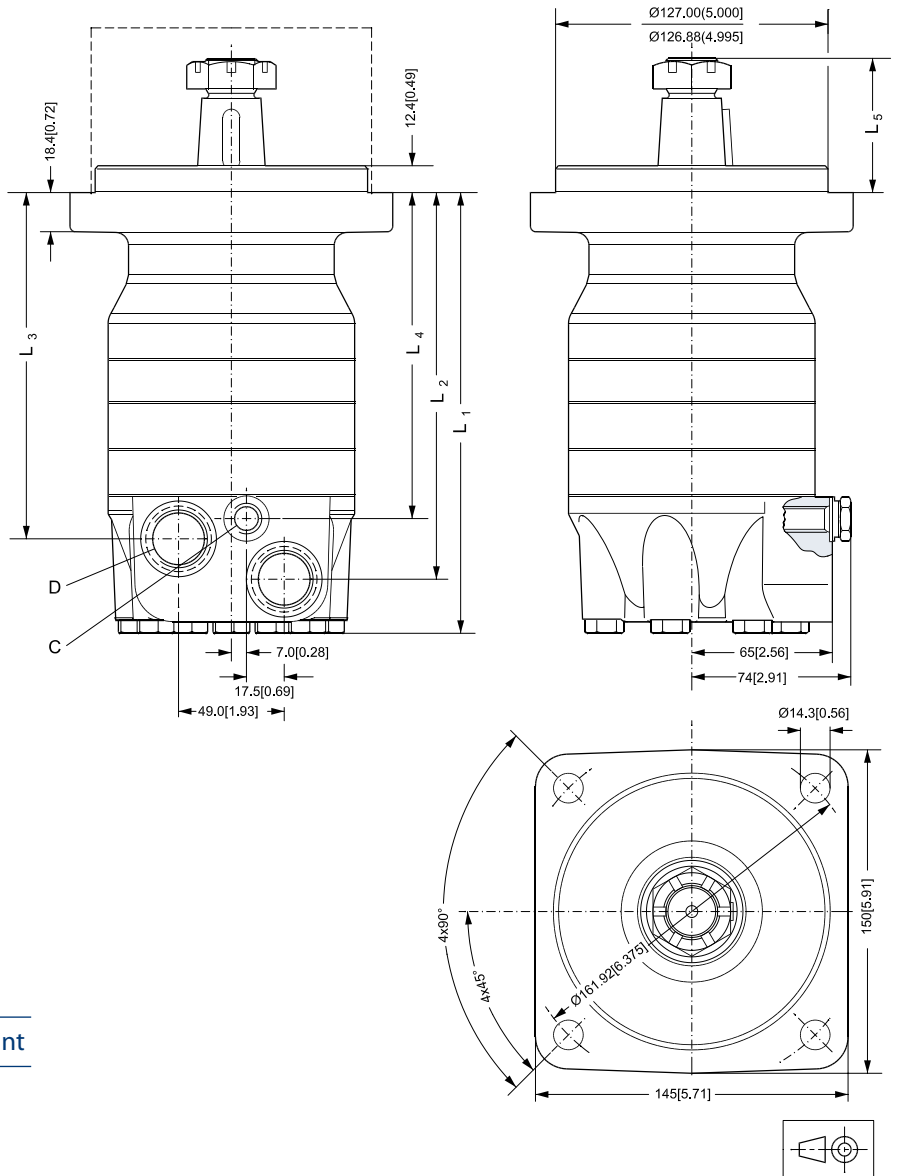

151-2054.10

TMKW with side port and drain connection

Dimensions

Type	mm L <sub>1</sub> [in]	mm L <sub>2</sub> [in]	mm L <sub>3</sub> [in]	mm L <sub>4</sub> [in]
TMKW 160	164.7 [6.48]	139.3 [5.48]	120.3 [4.74]	110.8 [4.36]
TMKW 200	170.7 [6.72]	145.3 [5.72]	126.3 [4.97]	116.8 [4.60]
TMKW 250	177.7 [7.00]	152.3 [6.00]	133.3 [5.25]	123.8 [4.87]
TMKW 315	186.4 [7.34]	161.0 [6.34]	142.0 [5.59]	132.5 [5.22]
TMKW 400	197.7 [7.78]	172.3 [6.78]	153.3 [6.00]	143.8 [5.66]
TMKW 470	207.9 [8.19]	182.5 [7.19]	163.5 [6.44]	154.0 [6.06]

C: Drain connection  $\frac{7}{16}$ - 20 UNF  
 D: 2 x  $1 \frac{1}{16}$ - 12 UN

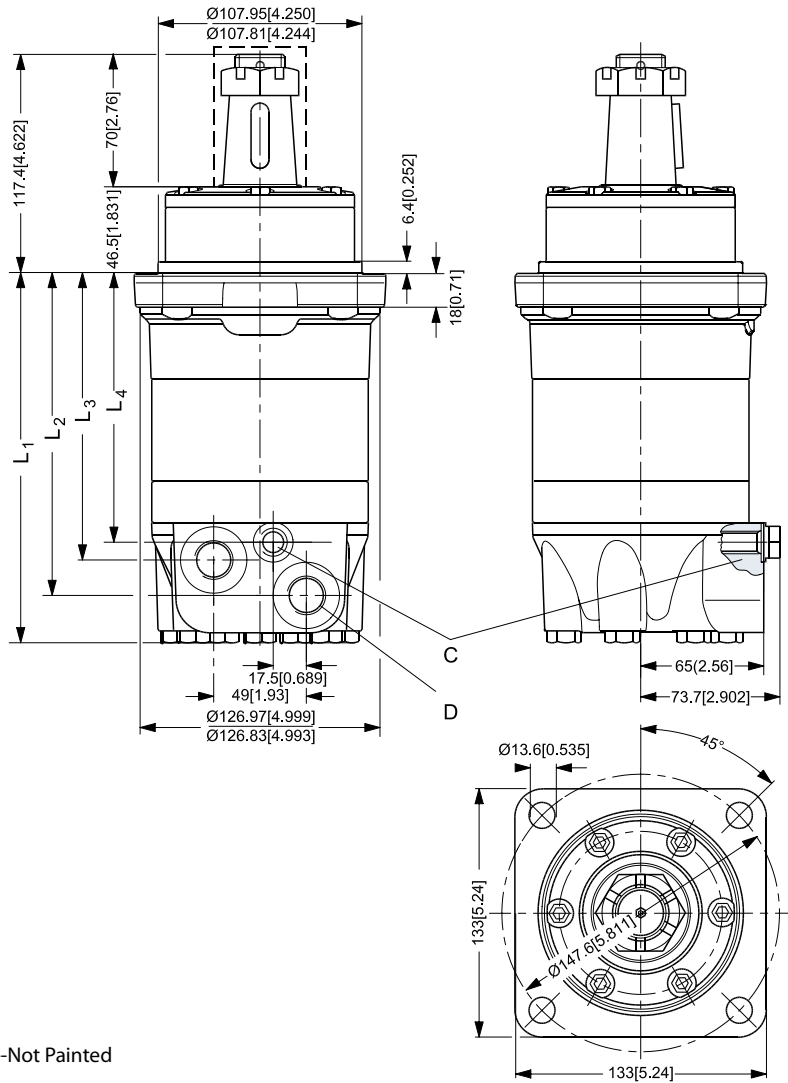

The stated dimensions are without paint

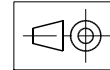

151-1993.11

**Dimensions**

*TMKW with end port and drain connection*

Type	L mm	[in]
TMKW 160	183.5	[7.2]
TMKW 200	189.5	[7.46]
TMKW 250	196.5	[7.74]
TMKW 315	205.2	[8.08]
TMKW 400	216.5	[8.52]
TMKW 470	226.7	[8.93]

C: Drain connection  
 $\frac{7}{16}$  - 20 UNF  
 D:  $2 \times \frac{7}{8}$  - 14 UNF

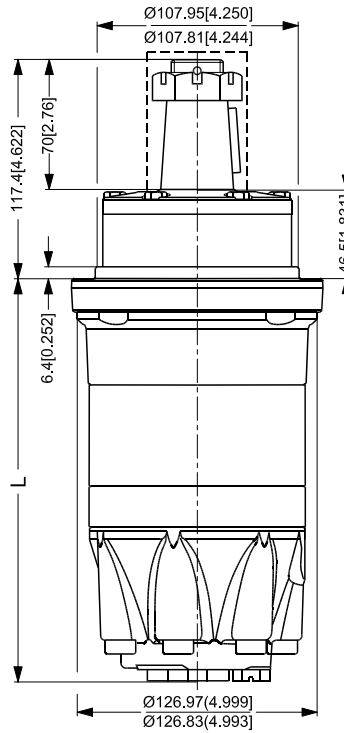
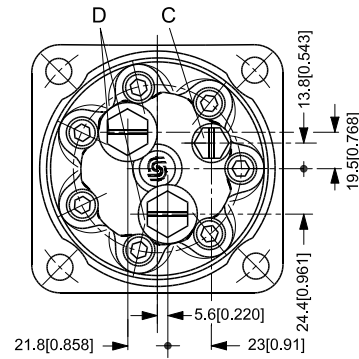

-----Not Painted

The stated dimensions are without paint

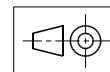
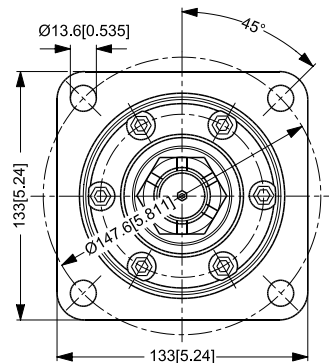

151-1992.11





**Dimensions**

Type	L mm	[in]
TMK FL 160	144.0	[5.67]
TMK FL 200	150.0	[5.91]
TMK FL 250	157.0	[6.18]
TMK FL 315	165.7	[6.52]
TMK FL 400	177.0	[6.97]
TMK FL 470	187.2	[7.37]

TMK FL with end port and drain connection

- C: Drain connection and brake release port  $7/16$ -20 UNF
- D:  $2 \times 7/8$ -14 UNF
- V: Vent port  $7/16$ -20 UNF

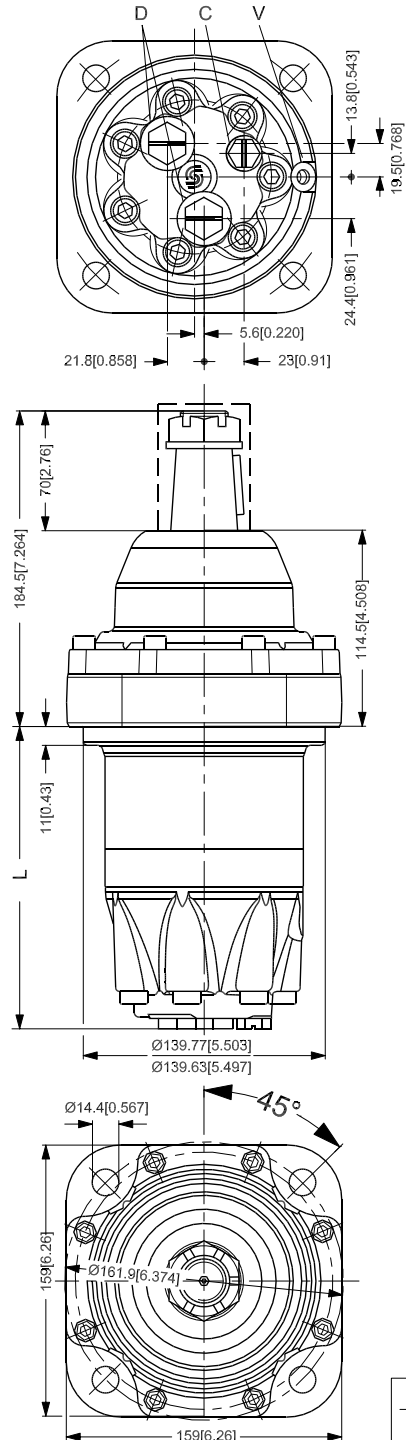

-----Not Painted

The stated dimensions are without paint

151-1991.12

Weight of Motors

Code no	Weight	
	kg	[lb]
151F6010	16.0	[35.30]
151F6011	16.5	[36.40]
151F6012	17.0	[37.50]
151F6013	17.5	[38.60]
151F6014	18.0	[39.71]
151F6015	18.5	[40.80]
151F6030	16.0	[35.30]
151F6031	16.5	[36.40]
151F6032	17.0	[37.50]
151F6033	17.5	[38.60]
151F6034	18.0	[39.71]
151F6035	18.5	[40.80]
151F6050	14.0	[30.9]
151F6051	14.5	[32.0]
151F6052	15.0	[33.1]
151F6053	15.5	[34.2]
151F6054	16.0	[35.3]
151F6055	16.5	[36.4]
151F6060	14.1	[31.2]
151F6061	14.6	[32.3]
151F6062	15.1	[33.4]
151F6063	15.6	[34.5]
151F6064	16.1	[35.6]
151F6065	16.6	[36.7]

Code no	Weight	
	kg	[lb]
151F6070	14.2	[31.2]
151F6071	14.7	[32.3]
151F6072	15.2	[33.3]
151F6073	15.7	[34.5]
151F6074	16.2	[35.6]
151F6075	16.7	[36.7]
151F6080	17.2	[37.9]
151F6081	17.7	[39.0]
151F6082	18.2	[40.1]
151F6083	18.7	[41.2]
151F6084	19.2	[42.3]
151F6085	19.7	[43.4]
151F6090	16.9	[37.2]
151F6091	17.4	[38.3]
151F6092	17.9	[39.4]
151F6093	18.4	[40.5]
151F6094	18.9	[41.6]
151F6095	19.4	[42.7]
151F6120	16.5	[36.5]
151F6121	17.0	[37.6]
151F6122	17.5	[38.7]
151F6123	18.0	[39.8]
151F6124	18.5	[40.9]
151F6125	19.0	[42.0]

Code no	Weight	
	kg	[lb]
151F6130	16.7	[36.7]
151F6131	17.2	[37.8]
151F6132	17.7	[38.9]
151F6133	18.2	[40.0]
151F6134	18.7	[41.1]
151F6135	19.2	[42.2]
151F6140	16.7	[36.8]
151F6141	17.2	[37.9]
151F6142	17.7	[39.0]
151F6143	18.2	[40.1]
151F6144	18.7	[41.2]
151F6145	19.2	[42.3]
11008903	19.5	[43.0]
11008904	20.0	[44.1]
11008905	20.5	[45.2]
11008906	21.0	[46.3]
11008907	21.5	[47.4]
11008908	22.0	[48.5]
11008909	19.5	[43.0]
11008910	20.0	[44.1]
11008911	20.5	[45.2]
11008912	21.0	[46.3]
11008913	21.5	[47.4]
11008914	22.0	[48.5]



TMK, TMKW and TMK FL  
Technical Information  
Notes

Notes



#### Products we offer:

- Bent Axis Motors
- Closed Circuit Axial Piston Pumps and Motors
- Displays
- Electrohydraulic Power Steering
- Electrohydraulics
- Hydraulic Power Steering
- Integrated Systems
- Joysticks and Control Handles
- Microcontrollers and Software
- Open Circuit Axial Piston Pumps
- Orbital Motors
- PLUS+1™ GUIDE
- Proportional Valves
- Sensors
- Steering
- Transit Mixer Drives

#### Members of the Sauer-Danfoss Group:

##### Comatrol

[www.comatrol.com](http://www.comatrol.com)

##### Schwarz Müller-Inverter

[www.schwarzmueller-inverter.com](http://www.schwarzmueller-inverter.com)

##### Turolla

[www.turollaocg.com](http://www.turollaocg.com)

##### Valmova

[www.valmova.com](http://www.valmova.com)

##### Hydro-Gear

[www.hydro-gear.com](http://www.hydro-gear.com)

##### Sauer-Danfoss-Daikin

[www.sauer-danfoss-daikin.com](http://www.sauer-danfoss-daikin.com)

**Sauer-Danfoss** is a global manufacturer and supplier of high-quality hydraulic and electronic components. We specialize in providing state-of-the-art technology and solutions that excel in the harsh operating conditions of the mobile off-highway market. Building on our extensive applications expertise, we work closely with our customers to ensure exceptional performance for a broad range of off-highway vehicles.

We help OEMs around the world speed up system development, reduce costs and bring vehicles to market faster.

Sauer-Danfoss – Your Strongest Partner in Mobile Hydraulics.

**Go to [www.sauer-danfoss.com](http://www.sauer-danfoss.com) for further product information.**

Wherever off-highway vehicles are at work, so is Sauer-Danfoss.

We offer expert worldwide support for our customers, ensuring the best possible solutions for outstanding performance. And with an extensive network of Global Service Partners, we also provide comprehensive global service for all of our components.

Please contact the Sauer-Danfoss representative nearest you.

Local address:

Sauer-Danfoss (US) Company  
2800 East 13th Street  
Ames, IA 50010, USA  
Phone: +1 515 239 6000  
Fax: +1 515 239 6618

Sauer-Danfoss ApS  
DK-6430 Nordborg, Denmark  
Phone: +45 7488 4444  
Fax: +45 7488 4400

Sauer-Danfoss GmbH & Co. OHG  
Postfach 2460, D-24531 Neumünster  
Krokamp 35, D-24539 Neumünster, Germany  
Phone: +49 4321 871 0  
Fax: +49 4321 871 122

Sauer-Danfoss-Daikin LTD.  
Shin-Osaka TERASAKI 3rd Bldg. 6F  
1-5-28 Nishimiyahara, Yodogawa-ku  
Osaka 532-0004, Japan  
Phone: +81 6 6395 6066  
Fax: +81 6 6395 8585