

ENGINEERING
TOMORROW



Technical Information

DDC Axial Piston Pumps

Size 20/24

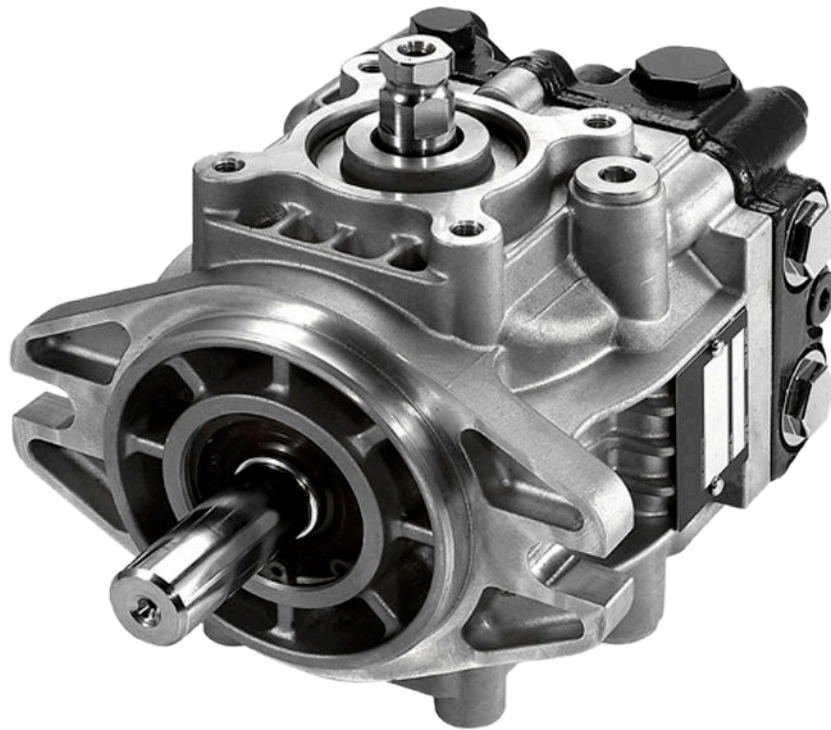

Revision history

Table of revisions

Date	Changed	Rev
January 2021	Minor update in Performance Specifications	0303
November 2020	Minor update in Fluid selection	0302
August 2020	Update CPRV setting	0301
June 2020	Changed document number and version from 'BC00000191' and 'L1104976' to 'BC152886484876'	0201
August 2019	Minor typo	0105
June 2019	Added Size 24	0104
December 2018	Corrected rounding error in performance specifications	0103
February 2017	Change charge pump housing	0102
January 2016	Add SAE-A, 13T Auxiliary Pad Option	0101
April 2015	Minor update in Model Code	BB
March 2015	Add Implement Pump and SAE A Mounting Flange Options, and Converted to Danfoss layout - DITA CMS	BA
March 2013	Paint and Tag	AC
November 2011	Minor edits	AB
October 2011	First edition	AA

Contents

General Description

Design.....	5
Key Features.....	5
Typical Applications.....	5
System Diagram.....	6
Schematic Diagram.....	7

Technical Specifications

Design Specifications.....	8
Performance Specifications.....	8
Operating Parameters.....	9
Fluid Specifications.....	9

Operation

High Pressure Relief / Check Valve (HPRV).....	10
High pressure relief / check valve with orifice.....	10
Bypass Function.....	11
Charge Pressure Relief Valve (CPRV).....	12
Loop flushing valve.....	13
Control.....	14
Direct Displacement Control.....	14
Control Handle Requirements.....	14

Operating Parameters

Overview.....	15
Input Speed.....	15
System Pressure.....	15
Charge Pressure.....	15
Charge Pump Inlet Pressure.....	16
Case Pressure.....	16
Temperature.....	16
Viscosity.....	16

System Design Parameters

Filtration System	17
Filtration.....	18
Suction Filtration.....	18
Charge Pressure Filtration.....	18
External Pressure Filtration.....	19
Independent Braking System.....	19
Fluid Selection.....	19
Reservoir.....	19
Case Drain.....	19
Charge Pump.....	20
Charge Pump Sizing/Selection.....	20
Charge Pump Output Flow.....	20
Implement Pump.....	21
Bearing Loads and Life.....	23
Applications with External Shaft Loads.....	23
Input Shaft.....	23
Shaft Torque.....	24
Mounting Flange Loads.....	25
Estimating Overhung Load Moments.....	25
Understanding and minimizing system noise.....	26
Size Equations.....	27

Model Code

Model Code: A, B, R, C, E, G, M.....	28
Model Code: H, K, F.....	29
Model Code: J, S, L.....	30
Model Code: N, P, Y, Z.....	31

Contents

Installation Drawings

With Aux-Pad, No Charge Pump, Left Trunnion, SAE A Flange Configuration.....	32
With Aux-Pad, No Charge Pump, Left Trunnion, SAE B Flange Configuration.....	34
With Charge Pump, No Aux-Pad, Left Trunnion, SAE A Flange Configuration.....	36
With Charge Pump, No Aux-Pad, Left Trunnion, SAE B Flange Configuration.....	38
With Implement Pump, No Aux-Pad, Left Trunnion, SAE A Flange Configuration.....	40
With Implement Pump, No Aux-Pad, Left Trunnion, SAE B Flange Configuration.....	42
Input Shafts: AA, BA, DA.....	44
Input Shafts: AB, BB, DB.....	45
Input Shafts: AC, BC, DC.....	46
Auxiliary Mounting Pads.....	47

Reference Literature

Literature.....	49
-----------------	----

General Description

Design

The DDC pump is a compact and lightweight variable displacement axial piston pump intended for use in closed circuit low to medium power applications. DDC pump is a direct displacement control pump utilizing an advanced slipper piston design. The flow rate is infinitely variable between zero and maximum. The direction of flow is commanded by tilting the swashplate in one direction or the other from the neutral (zero flow) position. Reversing the direction of flow reverses the direction of motor rotation.

Key Features

- Displacement 20/24 cm³/rev [1.22/1.46 in³/rev]
- Optional bypass valve and loop flushing valve
- Optional integral charge pump / Implement pump
- Compact design with best in class pressure ratings and durability
- Low noise
- Backed by a global network of Danfoss service provider
- Mounting flange (SAE-A / B)

Typical Applications

- Turf Care
 - Greens Mower
 - Zero Turn Radius Mower
 - Loaders
- Utility Vehicles
- Compact Agricultural Machinery
- Small Compactors
- Compact Construction Equipment

DDC Pump Cross-Sectional View

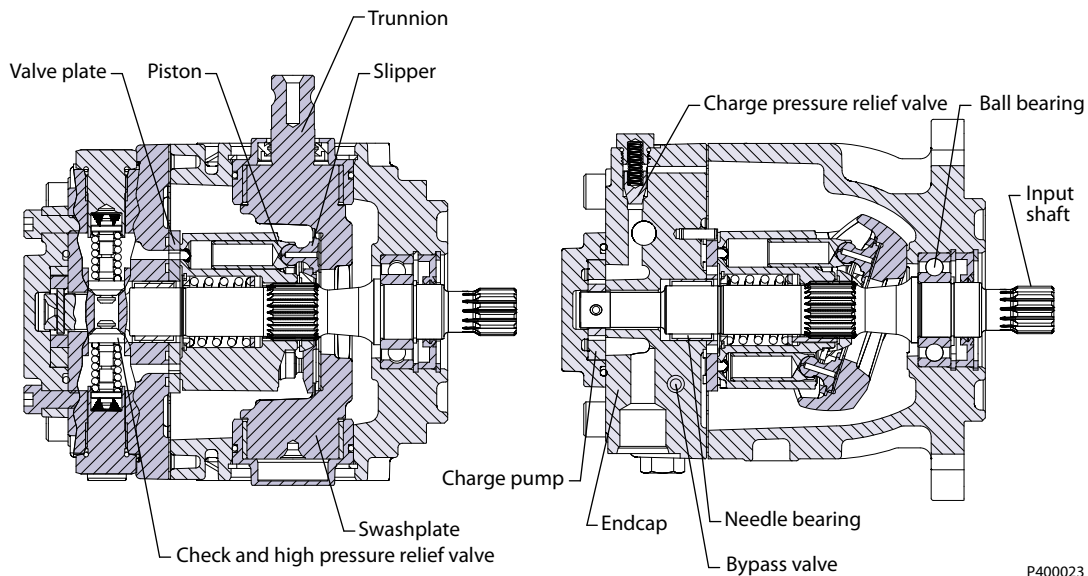

P400023

General Description

System Diagram

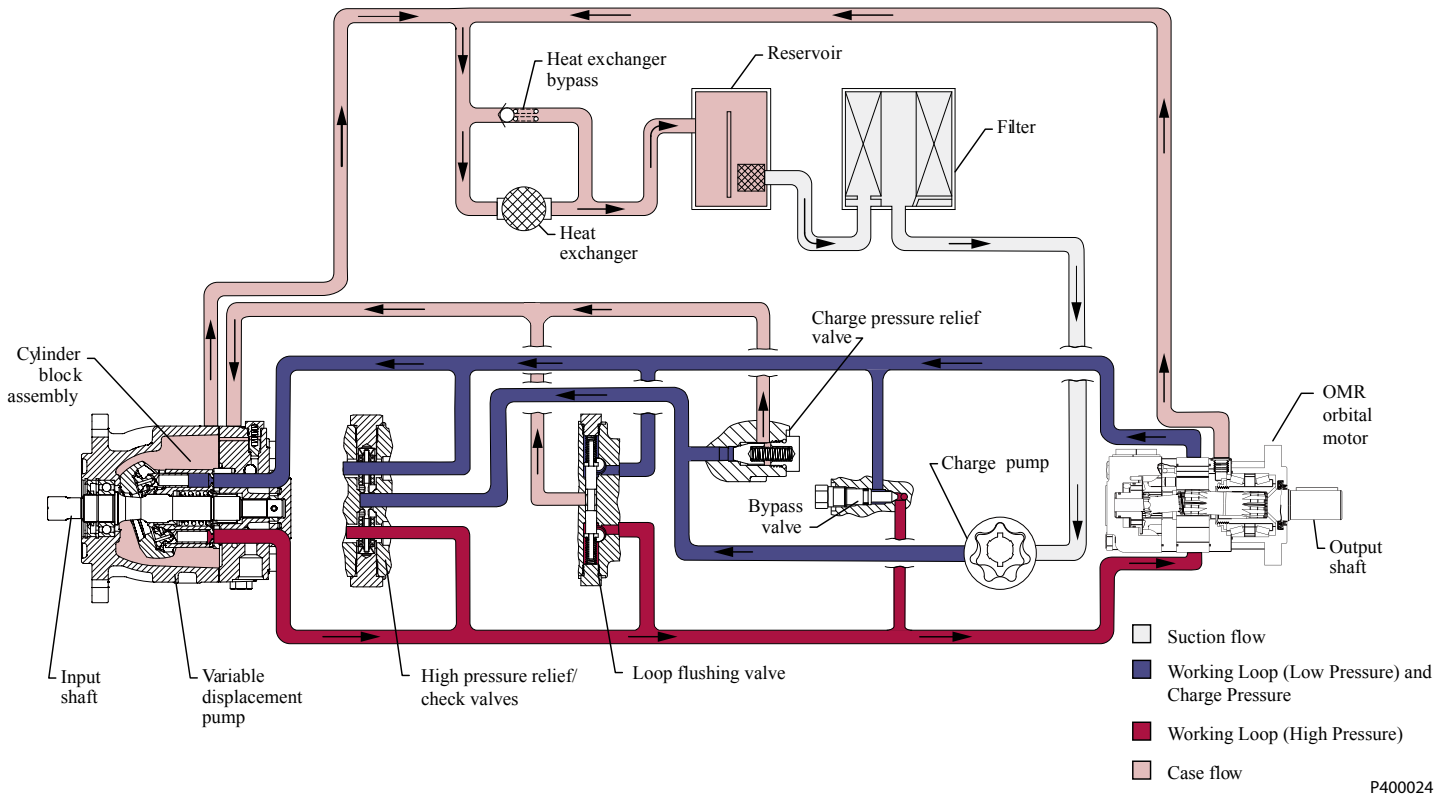

General Description

Schematic Diagram

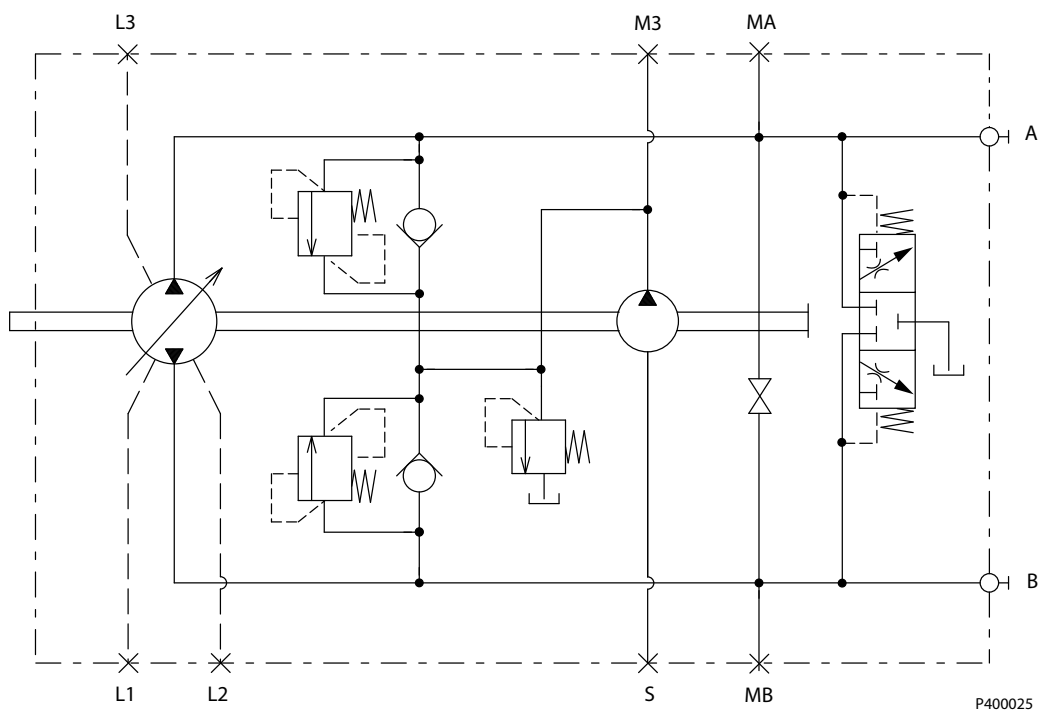

Technical Specifications

Design Specifications

Features	DDC pump
Design	Axial piston pump of journal trunnion design with variable displacement
Direction of input rotation	Clockwise or counterclockwise
Recommended installation position	Pump installation position is discretionary, however the recommended trunnion position is on the side or at the bottom. Consult Danfoss for application review when install with the trunnion position on the top. Vertical input shaft installation is acceptable. The housing must always be filled with hydraulic fluid. Recommended mounting for a multiple pump stack is to arrange the highest power flow towards the input source. Consult Danfoss for nonconformance to these guidelines.
Filtration configuration	Suction or charge pressure filtration
Other system requirements	Independent braking system, suitable reservoir and heat exchanger
Control type	Direct displacement control

Performance Specifications

Features	Units	DDC20	DDC24
Displacement ¹	cm ³ /rev [in ³ /rev]	0-20.0 [0-1.22]	0-24.0 [0-1.46]
Mass moment of inertia of rotating components	kg•m ² [slug•ft ²]	0.0009 [0.0006]	
Weight dry	With charge pump	10 [22.1]	
	With implement pump	11 [24.3]	
	With auxiliary pad	12 [26.4]	
Oil volume	Case only	liter [US gal]	0.7 [0.1]
Mounting flange		ISO3019-1 flange 101-2 (SAE B), 2 bolt ISO3019-1 flange 82-2 (SAE A), 2 bolt	
Input shaft outer diameter, Splines, key shafts ²		ISO 3019-1, outer dia 22mm-4 (SAE B, 13 teeth) ISO 3019-1, outer dia 22mm-1 (Straight Key, Ls) ISO 3019-1, outer dia 22mm-1 (Straight Key, Special length)	
Auxiliary mounting flange with metric fasteners, shaft outer diameter and splines		ISO 3019-1, flange 82 - 2, outer dia 16 mm - 4 (SAE A, 9 teeth) ISO 3019-1, flange 82 - 2, outer dia 19 mm - 4 (SAE A, 11 teeth)	
Suction ports		ISO 11926-1, 7/8 -14 (SAE O-ring boss)	
Main port configuration		ISO 11926-1, 7/8 -14 (SAE O-ring boss) Twin port, radial	
Case drain ports L1, L2 , L3		ISO 11926-1, 3/4 -16 (SAE O-ring boss)	
Other ports		See Installation Drawings on page 32	
Customer interface threads		Metric fasteners	

¹ Max Swashplate angle is 18 degrees.

² See [Installation Drawings](#) on page 32 for mounting flange SAE A.

Technical Specifications

Operating Parameters

For definitions of the following specifications, see [Operating Parameters](#) on page 15

Features		Units	DDC pump
Input speed	Minimum for internal charge supply ¹	min ⁻¹ (rpm)	500
	Minimum for external charge supply		500
	Rated		4000
	Maximum		4500
System pressure	Maximum working pressure	bar [psi]	300 [4350]
	Maximum pressure		345 [5004]
	Minimum low loop (above case)		4 [58]
Charge pressure (minimum)		bar@15 lpm [psi/USG]	7 [101]
Charge pump inlet pressure	Minimum (continuous)	bar (absolute) [in Hg vacuum]	0.8 [6]
	Minimum (cold start)		0.2 [24]
	Maximum		2.0
Case pressure	Rated	bar [psi]	1.5 [21.7]
	Maximum		3 [43.5]

¹ No load condition. Refer to System Design Parameters/[Charge Pump](#) on page 20 for details.

Fluid Specifications

Features		Units	DDC pump
Viscosity	intermittent ¹	mm ² /sec. [SUS]	5 [42]
	Minimum		7 [49]
	Recommended range		12 - 80 [66 - 370]
	Maximum (cold start) ²		1600 [7500]
Temperature range ³	Maximum (cold start)	°C	-20
	Recommended range		60 - 85
	Maximum continuous		104
	Maximum intermittent		115
Filtration (recommended minimum)	Cleanliness per ISO 4406	β-ratio	22/18/13
	Efficiency (charge pressure filtration)		β ₁₅₋₂₀ =75(β ₁₀ ≥10)
	Efficiency (suction filtration)	β ₃₅₋₄₅ =75(β ₁₀ ≥2)	
	Recommended inlet screen mesh size	μm	100 - 125

¹ Intermittent=Short term t < 1 min per incident and not exceeding 2 % of duty cycle based load-life.

² Cold start = Short term t < 3 min, p < 50 bar [725 psi], n < 1000 min⁻¹ (rpm)

³ At the hottest point, normally case drain port.

Operation

High Pressure Relief / Check Valve (HPRV)

The DDC pump is equipped with a combination high pressure relief and charge check valve. The high pressure relief valve (HPRV) function is a dissipative (with heat generation) direct acting pressure control valve for the purpose of limiting excessive system pressures. Each side of the transmission loop has a non-adjustable HPRV valve. When system pressure exceeds the factory setting of the valve, oil flows into the charge gallery. The valve is a differential pressure device working with system and charge pressure. The charge check function acts to replenish the low-side working loop with oil any time the low loop pressure falls below charge pressure.

Different pressure relief settings may be used at each system port. The order code specifies HPRV pressure setting availability.

High pressure relief / check valve with orifice

A HPRV valve with an orifice is available as an option. In some applications, it is desirable to use a HPRV/Check with an orifice to allow for easier neutral adjustment. The orifice connects the working loop to the charge gallery. It allows a small amount of loop leakage which expands the dead band around the neutral position of the swashplate. Most applications find it suitable to configure only one side of the system loop with an orificed HPRV. An orifice referenced to the high pressure side of the loop will decrease effective efficiency of the system and increase heat into the system. By locating an orifice only on the reverse drive side of the loop, system efficiency losses are minimized. Increased downhill creep may also be present.

The HPRV are set at the following flow rates

Check/HPRV without orifice	5 l/min [1.3 US gal/min]
Check/HPRV with orifice	17 l/min [4.5 US gal/min]

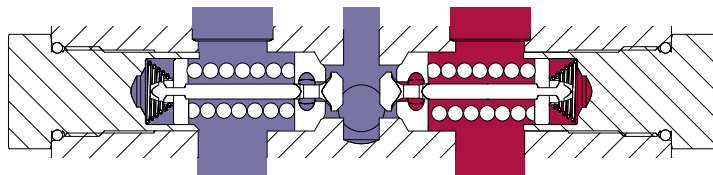

Caution

HPRV's are factory set at a low flow condition. Any application or operating condition which leads to elevated HPRV flow will cause a pressure rise above the factory setting. Contact your Danfoss representative for an application review. Using an HPRV with an orifice may increase downhill creep.

Warning

Unintended vehicle or machine movement hazard.

The vehicle must include a braking system redundant to the hydrostatic transmission, sufficient to stop and hold the vehicle or machine in the event of hydrostatic drive power loss.

Operation

Bypass Function

In some applications it is desirable to bypass the hydraulic fluid around the pump so the machine/load can be moved without rotating the pump shaft or prime mover. An optional bypass valve mechanically connects both A & B sides of the system pressure together. The bypass is fully opened when the valve is turned (opened) counterclockwise 3 revolutions. The valve must be fully closed for normal operation. Refer to the DDC pump outline drawings for location of the bypass valve.

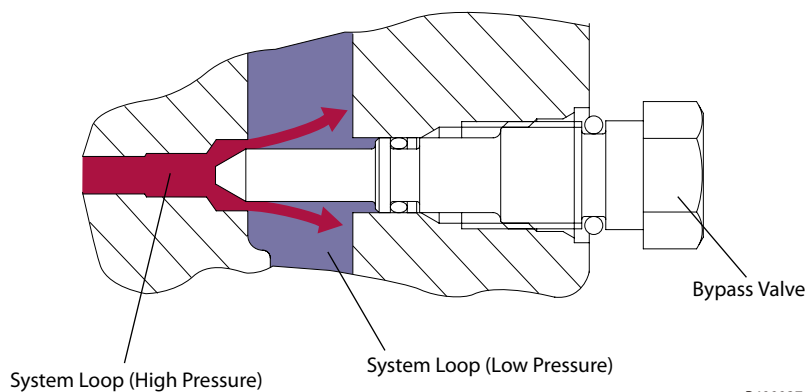

Bypass valve wrench size and torque

Wrench size	Torque N·m [lbf·ft]
17 mm external	12.0 [9.0]

Caution

Excessive speed or extended movement will damage the pump and motor(s)

Avoid excessive speeds and extended load/vehicle movement when using the bypass function. Damage to the drive motor is possible if the load or vehicle is moved at a speed greater than 20% of maximum or for a duration exceeding 3 minutes..

Operation

Charge Pressure Relief Valve (CPRV)

An internal charge pressure relief valve (CPRV) regulates charge pressure within the hydraulic circuit. The CPRV is a direct acting poppet valve that regulates charge pressure at a designated level above case pressure.

The charge pressure relief valve setting is specified within the model code of the pump. DDC pumps with charge pump have the CPRV set at 1800 rpm while DDC pumps without charge pump have the CPRV set with 15.0 l/min [4.0 US gal/min] of external supply flow. The 7 bar charge pressure rise rate, with flow, is approximately 0.8 bar/10 liter [4.4 psi/US gal]. The 18 and 21 bar charge pressure rise rate, with flow, is approximately 1.6 bar/10 liter [8.8 psi/US gal].

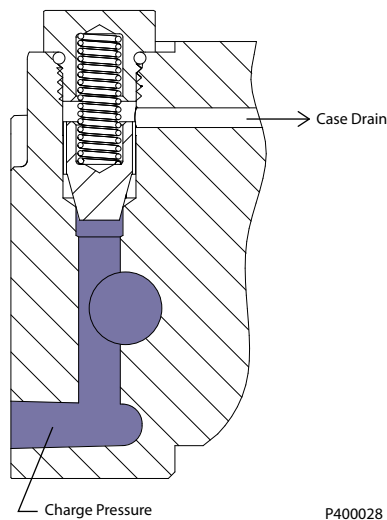

Caution

When a DDC pump is used with a variable motor, ensure the available charge pressure matches the required motor shift pressure. Contact your Danfoss representative for the availability of additional charge relief settings.

Operation

Loop flushing valve

DDC pumps are available with an optional integral loop flushing. A loop flushing valve will remove heat and contaminants from the main loop at a rate faster than otherwise possible.

The DDC loop flushing design is a simple spring centered shuttle spool with an orifice plug. The shuttle shifts at approximately 8 bar [115 psi]. The flushing flow is a function of the low loop system pressure (charge) and the size of the plug.

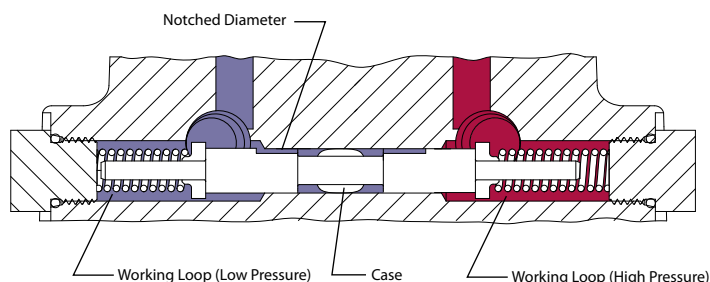

P400029

Loop flushing performance

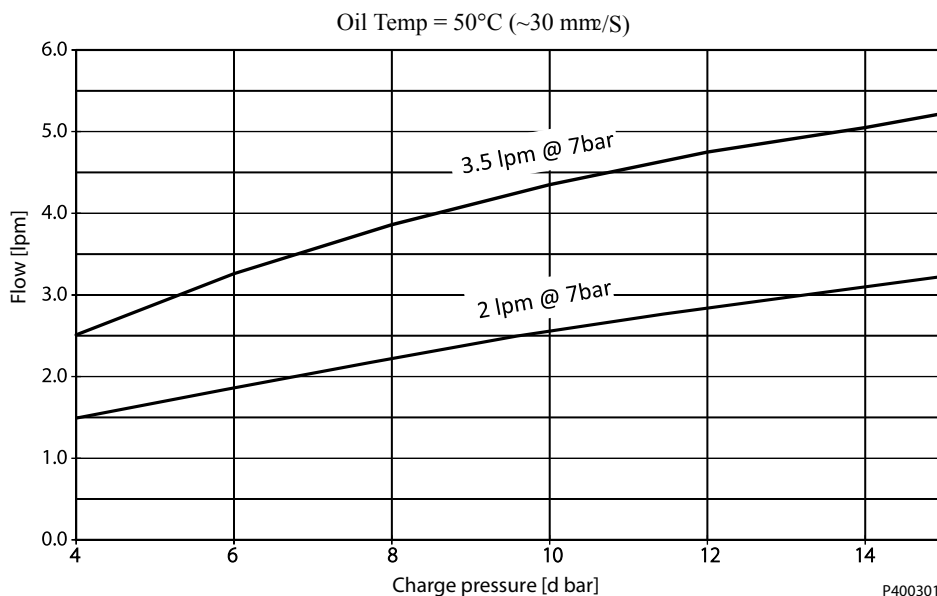

P400301

When a DDC pump is used with an external loop flushing shuttle valve, ensure that the charge setting of the pump matches the setting of the loop flushing shuttle valve. Contact your Danfoss representative for the availability of additional charge relief settings.

Operation

Control

Direct Displacement Control

The DDC pump features direct displacement control (DDC). The swashplate angle is set directly by a linkage attached to the swashplate trunnion. Moving the control lever changes the displacement and direction of flow.

The input shaft is configurable to the left or right side of the pump.

Control Handle Requirements

All DDC pumps will transfer hydraulic forces from within the transmission into the pump control arm where these forces are seen as a control arm torque. The nature and magnitude of the control arm torque is a function of transmission operating conditions (pump speed, pressure and displacement) and design of the DDC valve plate. During normal operation the control arm torque will be stroke reducing, whereas dynamic braking and downhill operation likely will result in stroke increasing control arm feedback. The driver and/or the mechanical linkage must be able to return the pump to neutral under all conditions. Contact Danfoss for additional application support regarding lower control arm torque options.

Maximum allowable control arm torque, applied from the customer linkage, is 79.1 Nm (700 in-lbs). Linkage stops may be required to limit input torque to the control arm. Maximum swashplate angle is +/- 18 degrees.

DDC Pumps Control Moment

Input=2000 rpm, Temp=50°C, Shell Tellus 46 Viscosity=30m²/s

Stroking Speed=1deg/sec, Standard HPRV

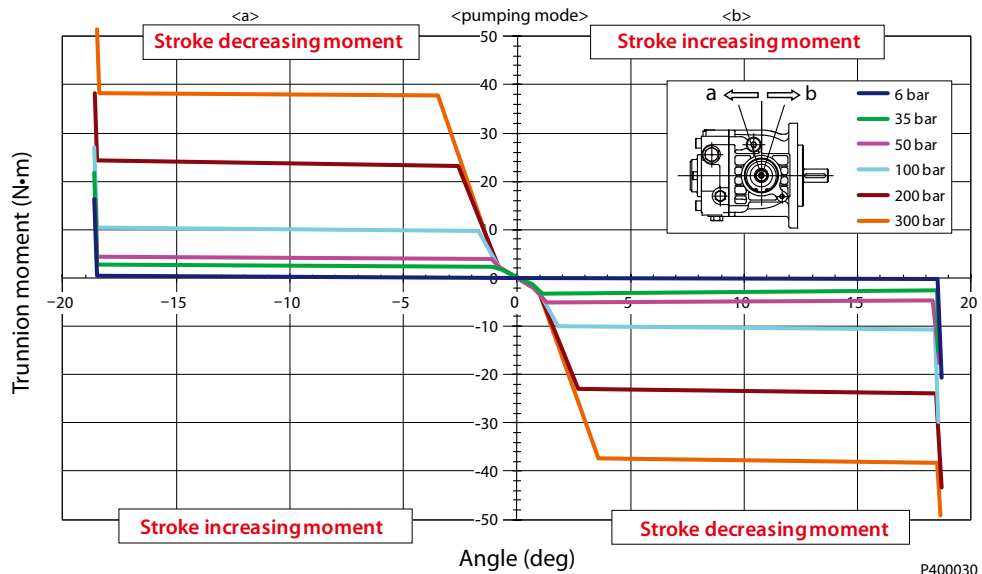

P400030

Operating Parameters

Overview

This section defines the operating parameters and limitations with regard to input speeds and pressures.

Input Speed

Minimum speed is the lowest input speed recommended during engine idle condition. Operating below minimum speed limits pump's ability to maintain adequate flow for lubrication and power transmission.

Rated speed is the highest input speed recommended at full power condition. Operating at or below this speed should yield satisfactory product life.

Maximum speed is the highest operating speed permitted. Exceeding maximum speed reduces product life and can cause loss of hydrostatic power and braking capacity. Never exceed the maximum speed limit under any operating conditions.

Operating conditions between Rated speed and Maximum speed should be restricted to less than full power and to limited periods of time. For most drive systems, maximum unit speed occurs during downhill braking or negative power conditions.

During hydraulic braking and downhill conditions, the prime mover must be capable of providing sufficient braking torque in order to avoid pump over speed. This is especially important to consider for turbocharged and Tier 4 engines.

Warning

Unintended vehicle or machine movement hazard.

Exceeding maximum speed may cause a loss of hydrostatic drive line power and braking capacity. You must provide a braking system, redundant to the hydrostatic transmission, sufficient to stop and hold the vehicle or machine in the event of hydrostatic drive power loss.

System Pressure

System pressure is the differential pressure between system ports A and B. It is the dominant operating variable affecting hydraulic unit life. High system pressure, which results from high load, reduces expected life. Hydraulic unit life depends on the speed and normal operating, or weighted average, pressure that can only be determined from a duty cycle analysis.

Application pressure is the high pressure relief setting normally defined within the order code of the pump. This is the applied system pressure at which the driveline generates the maximum calculated pull or torque in the application.

Maximum working pressure is the highest recommended Application pressure. Maximum working pressure is not intended to be a continuous pressure. Propel systems with Application pressures at, or below, this pressure should yield satisfactory unit life given proper component sizing.

Maximum pressure is the highest allowable Application pressure under any circumstance. Application pressures above Maximum Working Pressure will only be considered with duty cycle analysis and factory approval. Pressure spikes are normal and must be considered when reviewing maximum working pressure.

All pressure limits are differential pressures referenced to low loop (charge) pressure. Subtract low loop pressure from gauge readings to compute the differential.

Minimum low loop pressure (above case pressure) is the lowest pressure allowed to maintain a safe working condition in the low side of the loop.

Charge Pressure

An internal charge relief valve regulates charge pressure. Charge pressure maintains a minimum pressure in the low side of the transmission loop.

The charge pressure setting listed in the order code is the set pressure of the charge relief valve with the pump in neutral, operating at 1800 min⁻¹ [rpm], and with a fluid viscosity of 32 mm²/s [150 SUS]. Pumps

Operating Parameters

configured with no charge pump (external charge supply) are set with a charge flow of 15.0 l/min [4.0 US gal/min] and a fluid viscosity of 32 mm²/s [150 SUS].

The charge pressure setting is referenced to case pressure.

Charge Pump Inlet Pressure

At normal operating temperature charge inlet pressure must not fall below rated charge inlet pressure (vacuum).

Minimum charge inlet pressure is only allowed at cold start conditions. In some applications it is recommended to warm up the fluid (e.g. in the tank) before starting the engine and then run the engine at limited speed until the fluid warms up.

Maximum charge pump inlet pressure may be applied continuously.

Case Pressure

Under normal operating conditions, the rated case pressure must not be exceeded. During cold start case pressure must be kept below **maximum intermittent case pressure**. Size drain plumbing accordingly.

Caution

Possible component damage or leakage

Operation with case pressure in excess of stated limits may damage seals, gaskets, and/or housings, causing external leakage. Performance may also be affected since charge and system pressure are additive to case pressure.

Temperature

The high temperature limits apply at the hottest point in the transmission, which is normally the motor case drain. The system should generally be run at or below the rated temperature.

The **maximum intermittent temperature** is based on material properties and should never be exceeded.

Cold oil will not affect the durability of the transmission components, but it may affect the ability of oil to flow and transmit power; therefore temperatures should remain 16 °C [30 °F] above the pour point of the hydraulic fluid.

The **minimum temperature** relates to the physical properties of component materials. Size heat exchangers to keep the fluid within these limits. Danfoss recommends testing to verify that these temperature limits are not exceeded.

Ensure fluid temperature and viscosity limits are concurrently satisfied.

Viscosity

Viscosity For maximum efficiency and bearing life, ensure the fluid viscosity remains in the recommended range.

The **minimum viscosity** should be encountered only during brief occasions of maximum ambient temperature and severe duty cycle operation.

The **maximum viscosity** should be encountered only at cold start.

System Design Parameters

Filtration System

To prevent premature wear, ensure that only clean fluid enters the hydrostatic transmission circuit. A filter capable of controlling the fluid cleanliness to ISO 4406, class 22/18/13 (SAE J1165) or better, under normal operating conditions, is recommended. These cleanliness levels cannot be applied for hydraulic fluid residing in the component housing/case or any other cavity after transport.

Filtration strategies include suction or pressure filtration. The selection of a filter depends on a number of factors including the contaminant ingress rate, the generation of contaminants in the system, the required fluid cleanliness, and the desired maintenance interval. Filters are selected to meet the above requirements using rating parameters of efficiency and capacity.

Filter efficiency can be measured with a Beta ratio (β_x). For simple suction-filtered closed circuit transmissions and open circuit transmissions with return line filtration, a filter with a β -ratio within the range of $\beta_{35-45} = 75$ ($\beta_{10} \geq 2$) or better has been found to be satisfactory. For some open circuit systems, and closed circuits with cylinders being supplied from the same reservoir, a higher filter efficiency is recommended. This also applies to systems with gears or clutches using a common reservoir. For these systems, a charge pressure or return filtration system with a filter β -ratio in the range of $\beta_{15-20} = 75$ ($\beta_{10} \geq 10$) or better is typically required.

Because each system is unique, only a thorough testing and evaluation program can fully validate the filtration system. Please see *Design Guidelines for Hydraulic Fluid Cleanliness Technical Information, BC152886482150* for more information.

Cleanliness level and β_x -ratio ¹			
Filtration (recommended minimum)	Cleanliness per ISO 4406		22/18/13
	Efficiency (charge pressure filtration)	β -ratio	$\beta_{15-20} = 75$ ($\beta_{10} \geq 10$)
	Efficiency (suction and return line filtration)		$\beta_{35-45} = 75$ ($\beta_{10} \geq 2$)
	Recommended inlet screen mesh size	μm	100 – 125

¹ Filter β_x -ratio is a measure of filter efficiency defined by ISO 4572. It is defined as the ratio of the number of particles greater than a given diameter ("x" in microns) upstream of the filter to the number of these particles downstream of the filter.

System Design Parameters

Filtration

Suction Filtration

A suction circuit uses an internal charge pump. The filter is placed between the reservoir and the charge pump inlet. Do not exceed the inlet vacuum limits during cold start conditions.

Suction filtration

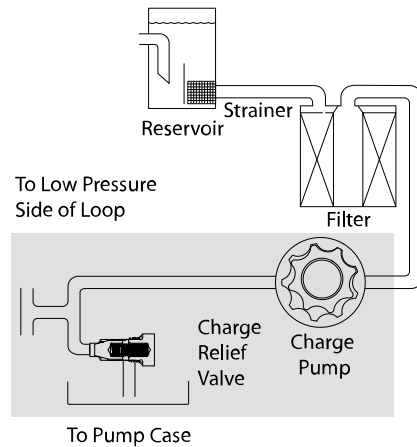

P400032

Charge Pressure Filtration

In a pressure filtration system the pressure filter is remotely mounted in the circuit, downstream of the charge supply. Pressure filtration is possible with, and without, an internal charge pump. Filters used in charge pressure filtration circuits should be rated to at least 35 bar [508 psi] pressure. Danfoss recommends locating a 100 – 125 micron screen in the reservoir or in the charge inlet when using charge pressure filtration.

A filter bypass valve is necessary to prevent damage to the hydrostatic system. In the event of high pressure drop associated with a blocked filter or cold start-up conditions, fluid may bypass the filter temporarily. Avoid working with an open bypass for an extended period. A visual or electrical bypass indicator is preferred. Proper filter maintenance is mandatory.

Charge pressure filtration

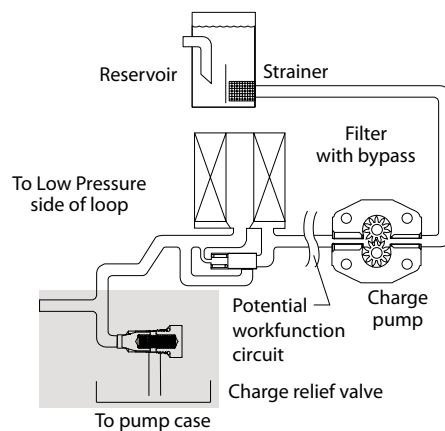

P400031

System Design Parameters

External Pressure Filtration

Charge supply is provided to the DDC pump from an auxiliary work function or dedicated gear pump circuit. After passing thru a remote filter, the flow enters the pump through the external charge supply port.

Independent Braking System

Warning

Unintended vehicle or machine movement hazard.

The loss of hydrostatic drive line power, in any mode of operation (forward, neutral, or reverse) may cause the system to lose hydrostatic braking capacity. You must provide a braking system, redundant to the hydrostatic transmission, sufficient to stop and hold the vehicle or machine in the event of hydrostatic drive power loss.

Fluid Selection

Ratings and performance data are based on operating with hydraulic fluids containing oxidation, rust and foam inhibitors. These fluids must possess good thermal and hydrolytic stability to prevent wear, erosion, and corrosion of pump components.

Caution

Never mix hydraulic fluids of different types.

Reservoir

The hydrostatic system reservoir should accommodate maximum volume changes during all system operating modes and promote de-aeration of the fluid as it passes through the tank.

A suggested minimum total reservoir volume is 5/8 of the maximum charge pump flow per minute with a minimum fluid volume equal to 1/2 of the maximum charge pump flow per minute. This allows 30 seconds fluid dwell for removing entrained air at the maximum return flow. This is usually adequate to allow for a closed reservoir (no breather) in most applications.

Locate the reservoir outlet (charge pump inlet) above the bottom of the reservoir to take advantage of gravity separation and prevent large foreign particles from entering the charge inlet line. A 100-125 μ m screen over the outlet port is recommended.

Position the reservoir inlet (fluid return) to discharge below the normal fluid level, toward the interior of the tank. A baffle (or baffles) will further promote de-aeration and reduce surging of the fluid.

Case Drain

The pump housing must remain full of oil at all times. The DDC pump is equipped with three case drain ports to provide flexibility for hose routing and pump installation. Connect a line from one of the case drain ports to the reservoir. Case drain fluid is typically the hottest fluid in the system.

System Design Parameters

Charge Pump

Charge flow is required on DDC pumps. The charge pump provides flow to make up for system leakage, maintain a positive pressure in the main circuit, and provide flow for cooling and filtration.

Many factors influence the charge flow requirements and the resulting charge pump size selection. These factors include system pressure, pump speed, pump swashplate angle, type of fluid, temperature, size of heat exchanger, length and size of hydraulic lines, auxiliary flow requirements, hydrostatic motor type, etc. When initially sizing and selecting hydrostatic units for an application, it is frequently not possible to have all the information necessary to accurately evaluate all aspects of charge pump size selection.

Unusual application conditions may require a more detailed review of charge pump sizing. Charge pressure must be maintained at a specified level under all operating conditions to prevent damage to the transmission. Danfoss recommends testing under actual operating conditions to verify this.

Charge Pump Sizing/Selection

In most applications a general guideline is that the charge pump displacement should be at least 10 % of the total displacement of all components in the system. Unusual application conditions may require a more detailed review of charge flow requirements. Please refer to *Selection of Drive line Components*, **BC157786484430** for a detailed procedure.

System features and conditions which may invalidate the 10 % guideline include (but are not limited to):

- Continuous operation at low input speeds {< 1500 min⁻¹ (rpm)}
- High shock loading
- High input shaft speeds
- LSHT motors with large displacement

Contact your Danfoss representative for application assistance if your application includes any of these conditions.

Charge Pump Output Flow

Flow at 7 bar [100 psi] charge relief setting, 30mm²/s [140SUS], 50 °C [122 °F]

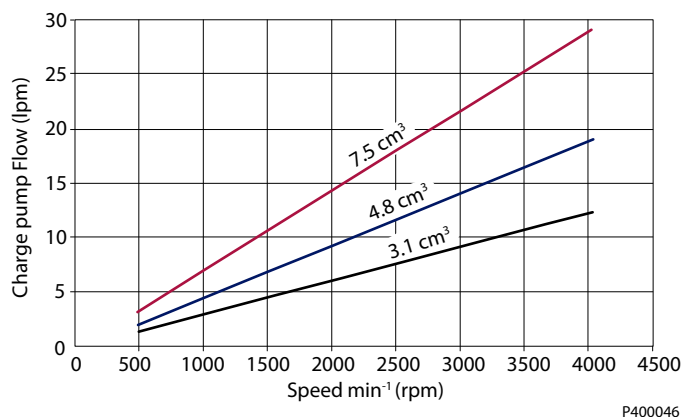

System Design Parameters

Implement Pump

Implement pump is an integrated charge pump that can be used for the lightly-loaded external work function. Since implement pump has both external gear pump and charge pump functions, it allows customers to apply more compact sizing than existing system using external gear pump.

The implement circuit must be of the “open center” type that allows oil from the charge pump circulating through the control valve to return to the transmission.

In the DDC implement circuit, flow from the charge (implement) pump flows first to the implement circuit control valve, then to the charge relief and charge check valves. The implement circuit must be designed to return the implement flow to the transmission. The customer must provide an implement circuit relief valve in addition to the implement control valve. It is also recommended that the customer provide a charge pressure filter between the implement control valve and the transmission to prevent any contaminants created in the implement circuit actuator(s) from entering the charge circuit.

Implement Pump Pressure Specifications

Implement Pump Maximum Pressure	bar [psi]	85 [1230]
Implement Pump Maximum working pressure (Implement circuit relief pressure setting) ¹		70 [1015]

¹ Continuous operation at implement pump relief pressure = Short term t <30sec

Flow at 11mm²/s [63SUS], 80°C [176°F]

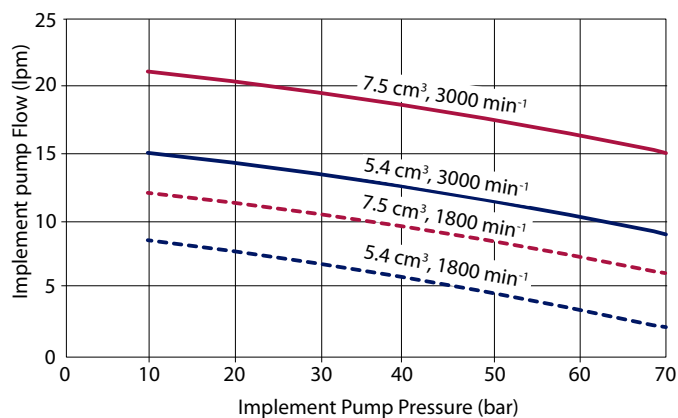

P400136

Low input speed with high pressure and high temperature may cause the flow shortage.

System Design Parameters

Implement Circuit - Schematic Diagram

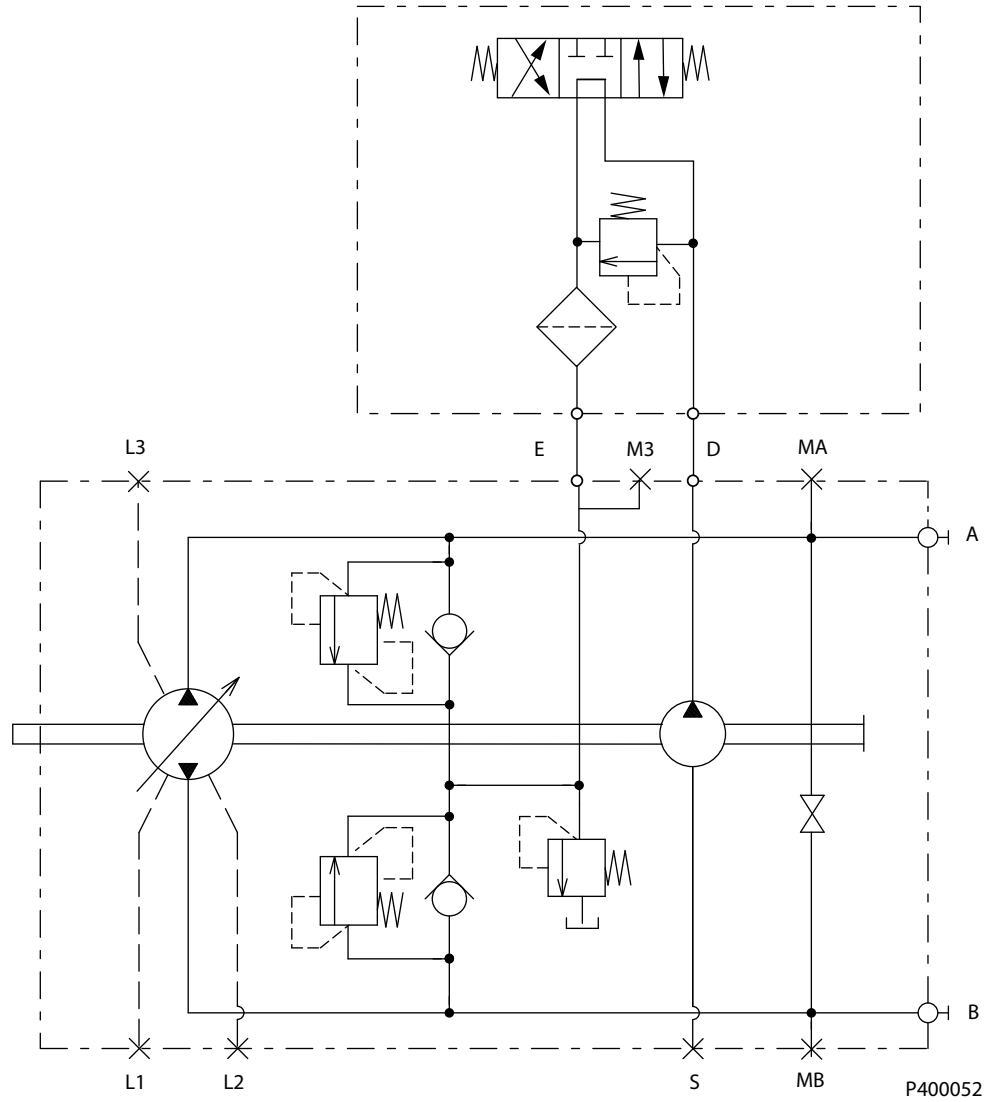

System Design Parameters

Bearing Loads and Life

Bearing life is a function of speed, system pressure, charge pressure, and swashplate angle, plus any external side or thrust loads. The influence of swashplate angle includes displacement as well as direction. External loads are found in applications where the pump is driven with a side/thrust load (belt or gear) as well as in installations with misalignment and improper concentricity between the pump and drive coupling. All external side loads will act to reduce the normal bearing life of a pump. Other life factors include oil type, viscosity and cleanliness.

In vehicle **propel** drives with no external shaft loads and where the system pressure and swashplate angle are changing direction and magnitude regularly, the normal B₁₀ bearing life (90 % survival) will exceed the hydraulic load-life of the unit.

Bearing B₁₀ Life

Bearing Life (max. swashplate angle)	At 140 bar system pressure 7 bar charge pressure 1800 rpm	B ₁₀ hours	10000
--	---	-----------------------	-------

Applications with External Shaft Loads

DDC pump is designed with bearings that can accept some external radial load. When external loads are present, the allowable radial shaft loads are a function of the load position relative to the mounting flange, the load orientation relative to the internal loads, and the operating pressures of the hydraulic unit. In applications where external shaft loads cannot be avoided, the impact on bearing life can be minimized by proper orientation of the load. Optimum pump orientation is a consideration of the net loading on the shaft from the external load, the pump rotating group and the charge pump load.

- In applications where the pump is operated such that nearly equal amounts of forward vs. reverse swashplate operation is experienced; bearing life can be optimized by orientating the external side load at 90° or 270° such that the external side load acts 90° to the rotating group load (for details see drawing below).
- In applications where the pump is operated such that the swashplate is predominantly (> 75 %) on one side of neutral (ie vibratory, conveyor, typical propel); bearing life can be optimized by orientating the external side load generally opposite of the internal rotating group load. The direction of internal loading is a function of rotation and which system port has flow out.
- DDC pump is designed with bearings that can accept some thrust load such that incidental thrust loads are of no consequence. When thrust loads are anticipated, the allowable load will depend on many factors and it is recommended that an application review be conducted.

Contact Danfoss for a bearing life review if external side loads are present.

[Thrust loads should be avoided. If thrust loads are anticipated, contact your Danfoss representative.](#)

Input Shaft

The **maximum allowable radial load (Re)** is based on the maximum external moment (Me) and the distance (L) from the mounting flange to the load.

$$Re = Me / L$$

Me Shaft moment

L Flange distance

Re External force to the shaft

Fa Internal rotating group load (changes with direction of flow)

System Design Parameters

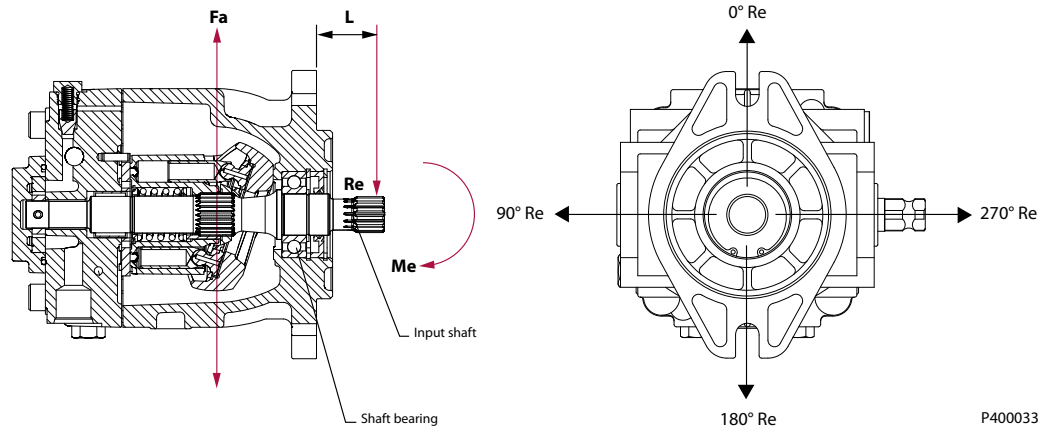

Maximum allowable radial load (Re)

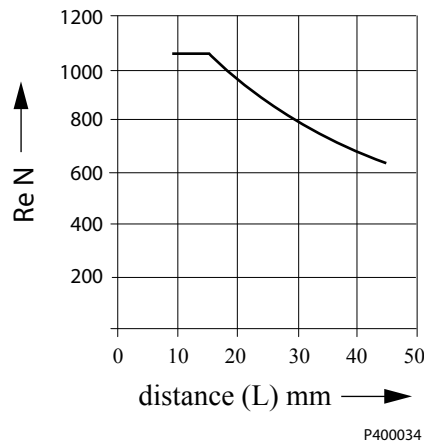

Danfoss recommends clamp-type couplings for applications with radial shaft loads

Contact your Danfoss representative for an evaluation of unit bearing life if you have continuously applied external loads exceeding 25 % of the maximum allowable radial load (Re) or the pump swashplate is positioned on one side of center all or most of the time.

Shaft Torque

The **rated torque** is a measure of tooth wear and is the torque level at which a normal spline life of 2×10^9 shaft revolutions can be expected. The rated torque presumes a regularly maintained minimum level of lubrication via a moly- disulfide grease in order to reduce the coefficient of friction and to restrict the presence of oxygen at the spline interface. It is also assumed that the mating spline has a minimum hardness of Rc 55 and full spline depth.

Maximum torque ratings are based on torsional fatigue strength considering 100.000 full load reversing cycles. However, a spline running in oil-flooded environment provides superior oxygen restriction in addition to contaminant flushing. The rated torque of a flooded spline can increase to that of the maximum published rating. A flooded spline would be indicative of a pump driven by a pump drive or plugged into an auxiliary pad of a pump.

Maintaining a spline engagement at least equal to the Pitch Diameter will also maximize spline life. Spline engagements of less than $\frac{3}{4}$ Pitch Diameter are subject to high contact stress and spline fretting.

Alignment between the mating spline's pitch diameters is another critical factor in determining the operating life of a splined drive connection. *Plug-in*, or *rigid* spline drive installations can impose severe radial loads on the shaft. The radial load is a function of the transmitted torque and shaft eccentricity.

System Design Parameters

Increased spline clearance will not totally alleviate this condition; BUT, increased spline clearance will prevent mechanical interference due to misalignment or radial eccentricity between the pitch diameters of the mating splines. Maximize spline life by adding an intermediate coupling between the bearing supported splined shafts.

Mounting Flange Loads

Estimating Overhung Load Moments

Adding auxiliary pumps and/or subjecting pumps to high shock loads may result in excessive loading of the mounting flange. Applications which experience extreme resonant vibrations or shock may require additional pump support. You can estimate the overhung load moment for multiple pump mounting using the formula below.

$$M_S = G_S (W_1 L_1 + W_2 L_2 + \dots + W_n L_n)$$

$$M_C = G_C (W_1 L_1 + W_2 L_2 + \dots + W_n L_n)$$

Where:

M_C Rated load moment N•m [lbf•in]

M_S Shock load moment N•m [lbf•in]

G_C Rated (vibratory) acceleration (G's)* m/s² [ft/s²]

G_S Maximum (shock) acceleration (G's)* m/s² [ft/s²]

W_n Weight of nth pump

L_n Distance from mounting flange to CG (center of gravity) of nth pump

(Refer to [Installation Drawings](#) on page 32 to locate CG of pump.)

* Carry out calculations by multiplying gravity ($g = 9.81 \text{ m/s}^2 [32 \text{ ft/s}^2]$) with a given factor. This factor depends on the application.

Refer to the table below, for allowable overhung load moment values.

Shaft loading parameters

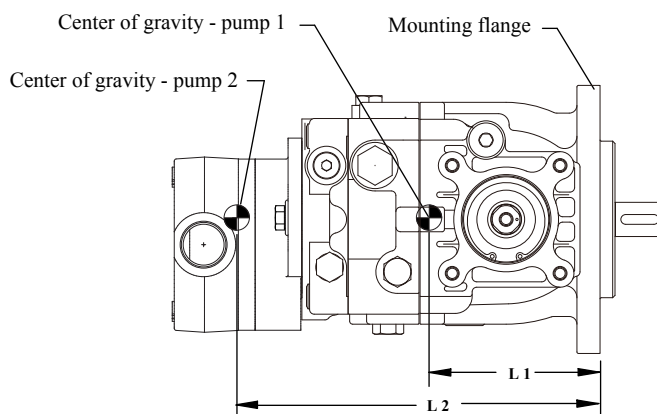

P400035

System Design Parameters

Mounting flange load

	Rated moment (M_R)		Shock load moment (M_S)	
	N·m	[lbf·in]	N·m	[lbf·in]
SAE B flange	461	[4080]	865	[7655]
SAE A flange	216	[1912]	404	[3576]

Only SAE B flange is available for the front pump of Tandem pump.

Typical G loads for various applications

Application	Rated (vibratory) acceleration (G_R)	Maximum (shock) acceleration (G_S)
Skid steer loader	4	10
Trencher (rubber tires)	3	8
Asphalt paver	2	6
Windrower	2	5
Aerial lift	1.5	4
Turf care vehicle	1.5	4
Vibratory roller	6	10

Understanding and minimizing system noise

Noise is transmitted in fluid power systems in two ways: as fluid borne noise, and structure borne noise.

Fluid-borne noise (pressure ripple or pulsation) is created as pumping elements discharge oil into the pump outlet. It is affected by the compressibility of the oil, and the pump's ability to transition pumping elements from high to low pressure. Pulsations travel through the hydraulic lines at the speed of sound until there is a change (such as an elbow) in the line. Amplitude varies with overall line length and position.

Structure borne noise is transmitted wherever the pump casing connects to the rest of the system. The way system components respond to excitation depends on their size, form, material, and mounting.

[System lines and pump mounting can amplify pump noise.](#)

Follow these suggestions to help minimize noise in your application:

- Use flexible hoses.
- Limit system line length.
- If possible, optimize system line position to minimize noise.
- If you must use steel plumbing, clamp the lines.
- If you add additional support, use rubber mounts.
- Test for resonance in the operating range; if possible avoid them.

System Design Parameters

Size Equations

The following equations are helpful when sizing hydraulic transmissions. Generally, the sizing process is initiated by an evaluation of the machine system to determine the required transmission speed and torque to perform the necessary work function. Refer to *Selection of Drive Line Components*, **BC157786484430**, for a more complete description of hydrostatic drive line sizing.

Based on SI units

Based on US units

$$\text{Output flow } Q = \frac{V_g \cdot n \cdot \eta_v}{1000} \quad (\text{l/min})$$

$$\text{Output flow } Q = \frac{V_g \cdot n \cdot \eta_v}{231} \quad (\text{US gal/min})$$

$$\text{Input torque } M = \frac{V_g \cdot \Delta p}{20 \cdot \pi \cdot \eta_m} \quad (\text{N}\cdot\text{m})$$

$$\text{Input torque } M = \frac{V_g \cdot \Delta p}{2 \cdot \pi \cdot \eta_m} \quad (\text{lb}\cdot\text{in})$$

$$\text{Input power } P = \frac{M \cdot n \cdot \pi}{30\,000} = \frac{Q \cdot \Delta p}{600 \cdot \eta_t} \quad (\text{kW})$$

$$\text{Input power } P = \frac{M \cdot n \cdot \pi}{198\,000} = \frac{Q \cdot \Delta p}{1714 \cdot \eta_t} \quad (\text{hp})$$

Variables:

- V_g** = Displacement per rev.
- p_o** = Outlet pressure
- p_i** = Inlet pressure
- Δp** = p_{HD} – p_{ND} (system pressure)
- n** = Speed
- η_v** = Volumetric efficiency
- η_m** = Mechanical efficiency
- η_t** = Overall efficiency (η_v • η_m)

SI units [US units]

- cm³/rev [in³/rev]
- bar [psi]
- bar [psi]
- bar [psi]
- min⁻¹ (rpm)

Installation Drawings

With Aux-Pad, No Charge Pump, Left Trunnion, SAE A Flange Configuration

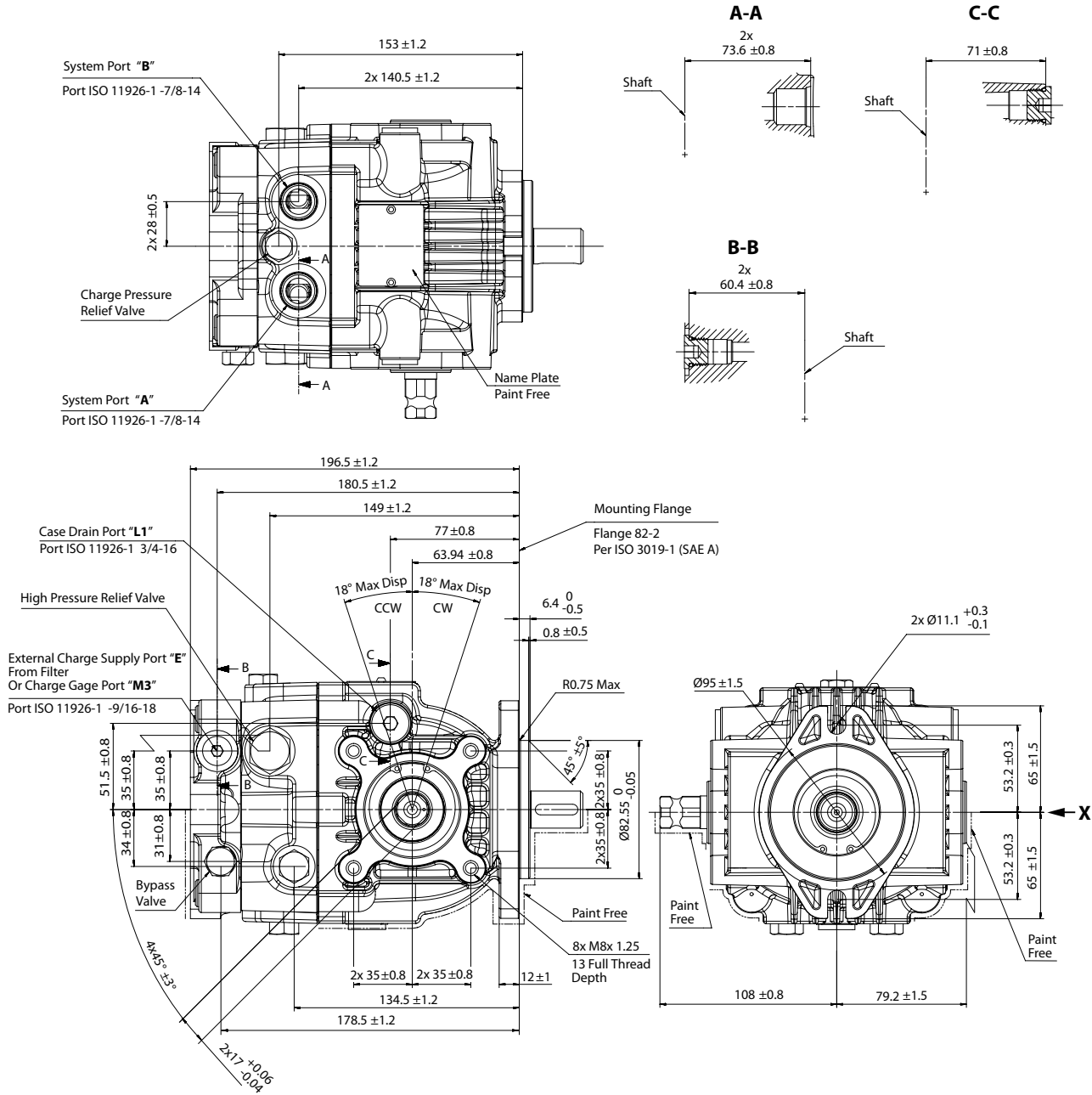

P400133

Input shaft rotation	CW				CCW			
	Right		Left		Right		Left	
Trunnion rotation	CW	CCW	CW	CCW	CW	CCW	CW	CCW
Port A flow	Out	In	In	Out	In	Out	Out	In
Port B flow	In	Out	Out	In	Out	In	In	Out

Installation Drawings

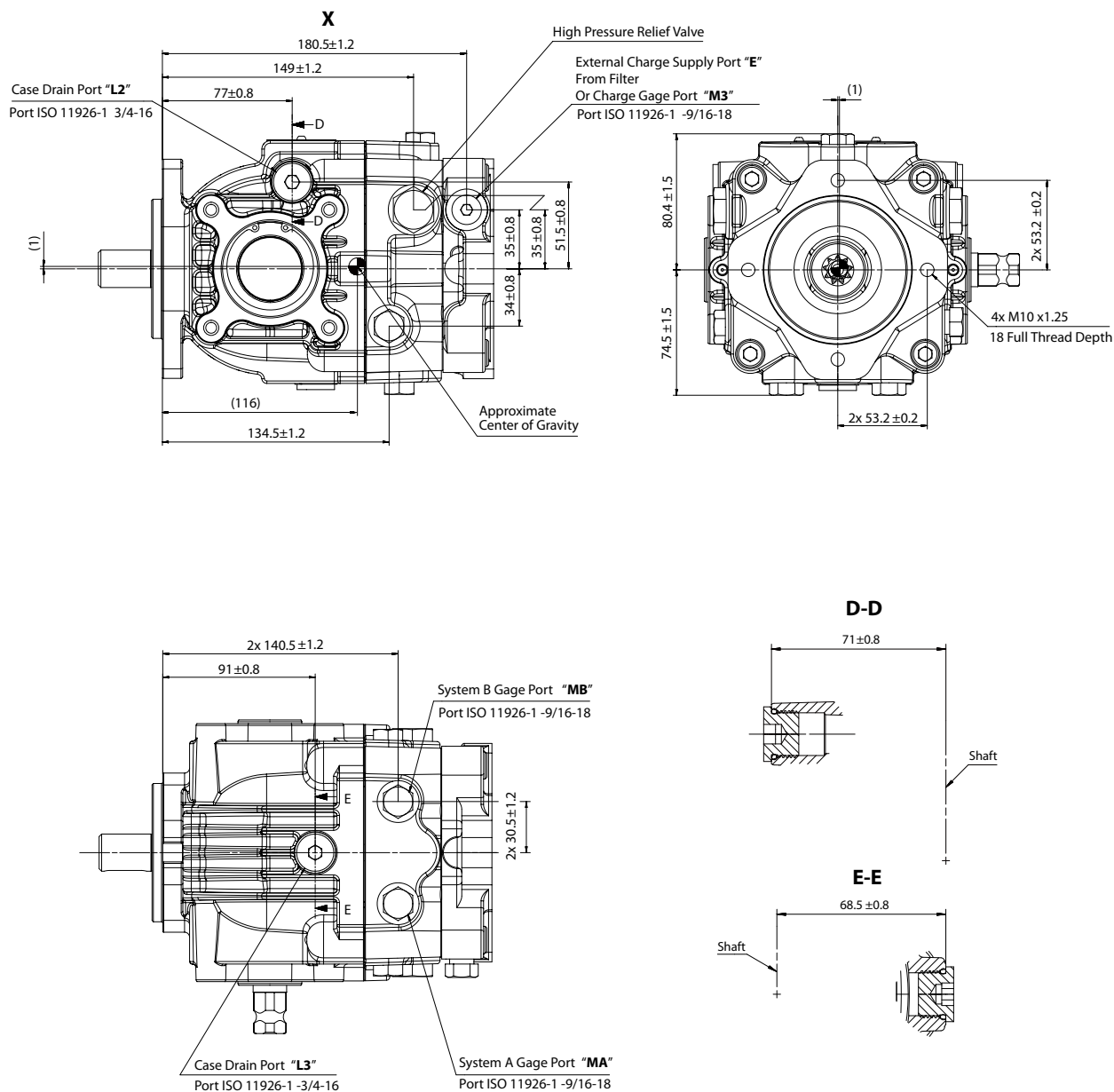

P400132

Installation Drawings

With Aux-Pad, No Charge Pump, Left Trunnion, SAE B Flange Configuration

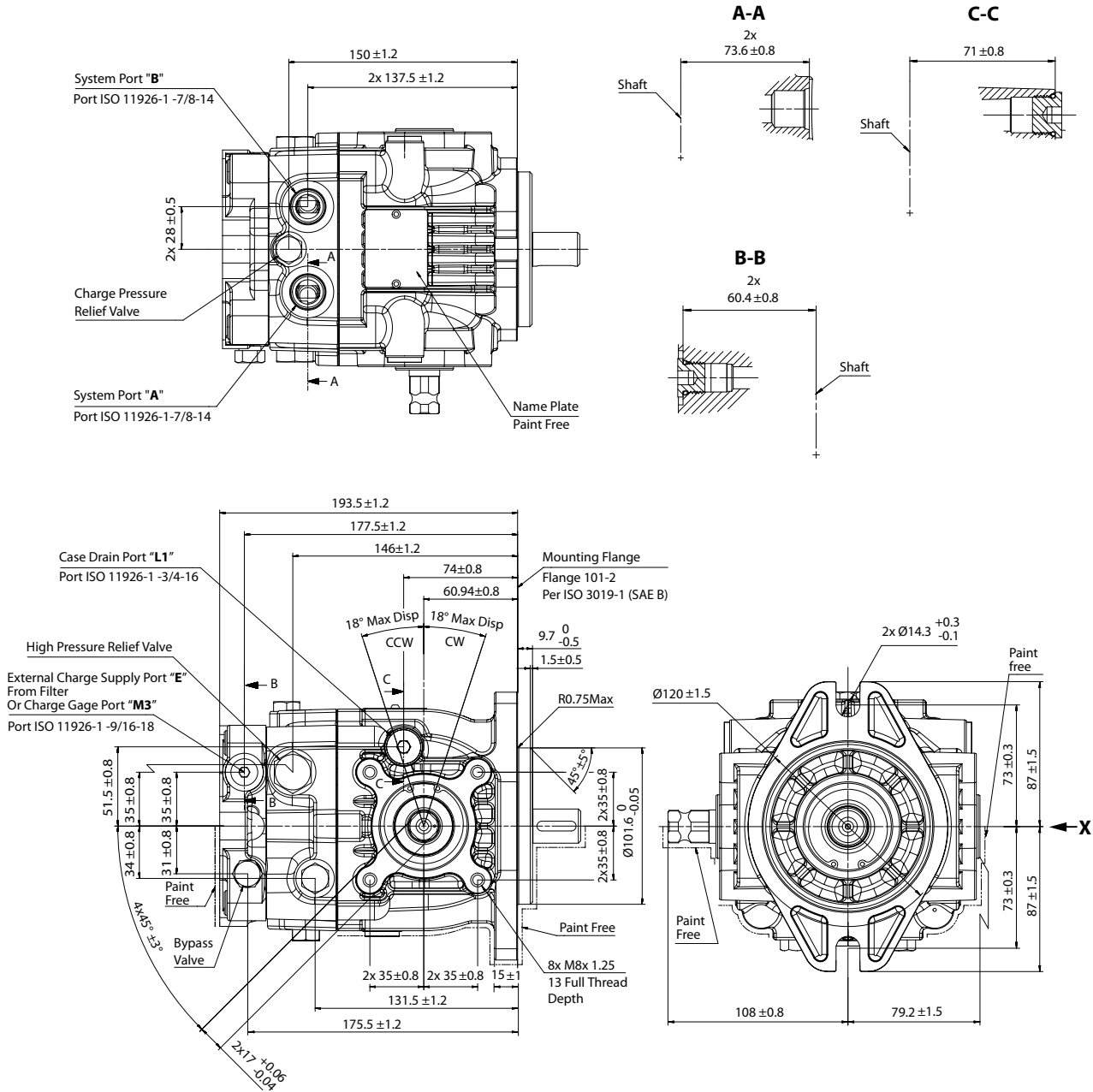

P400036

Installation Drawings

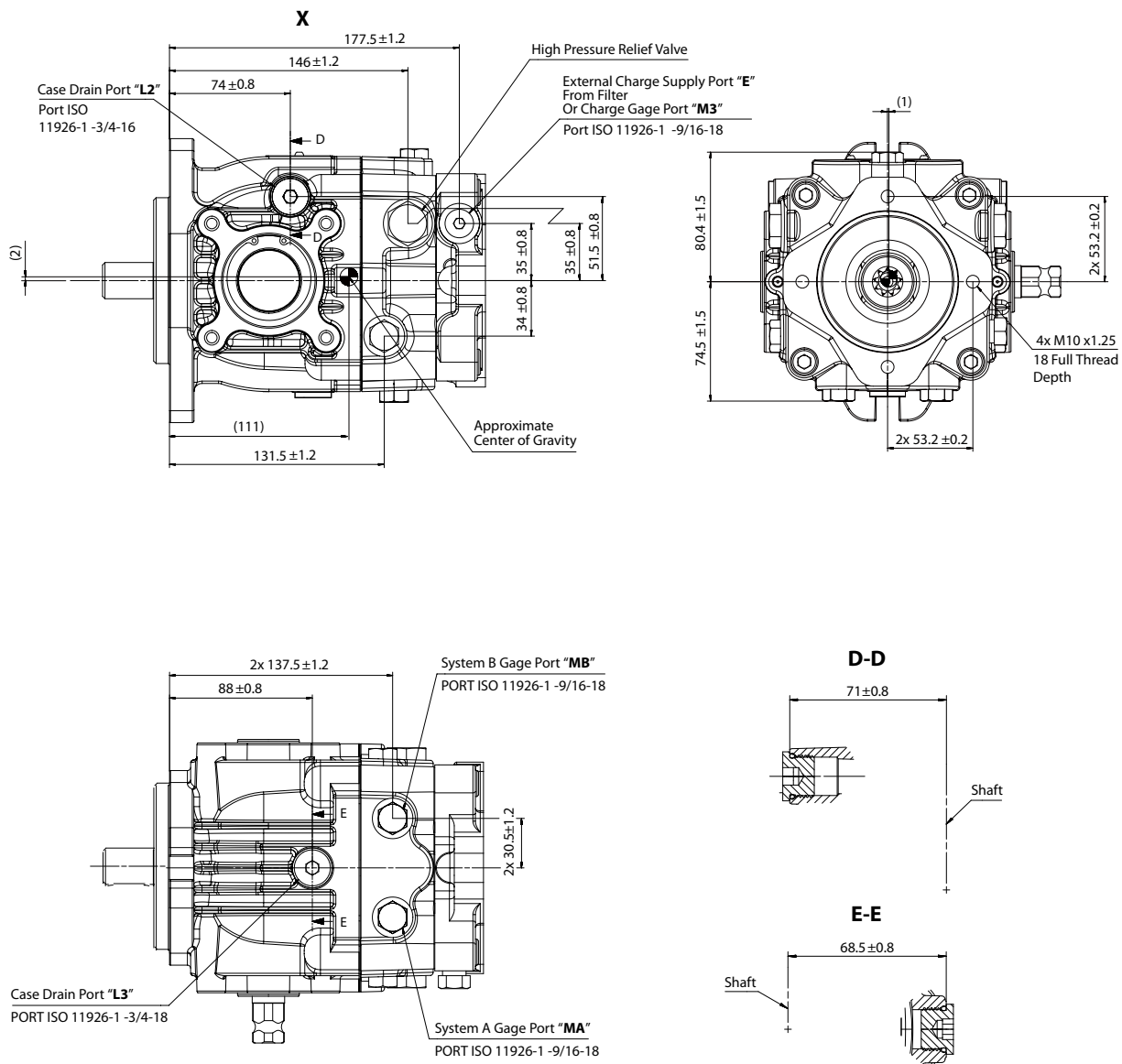

P400037

Installation Drawings

With Charge Pump, No Aux-Pad, Left Trunnion, SAE A Flange Configuration

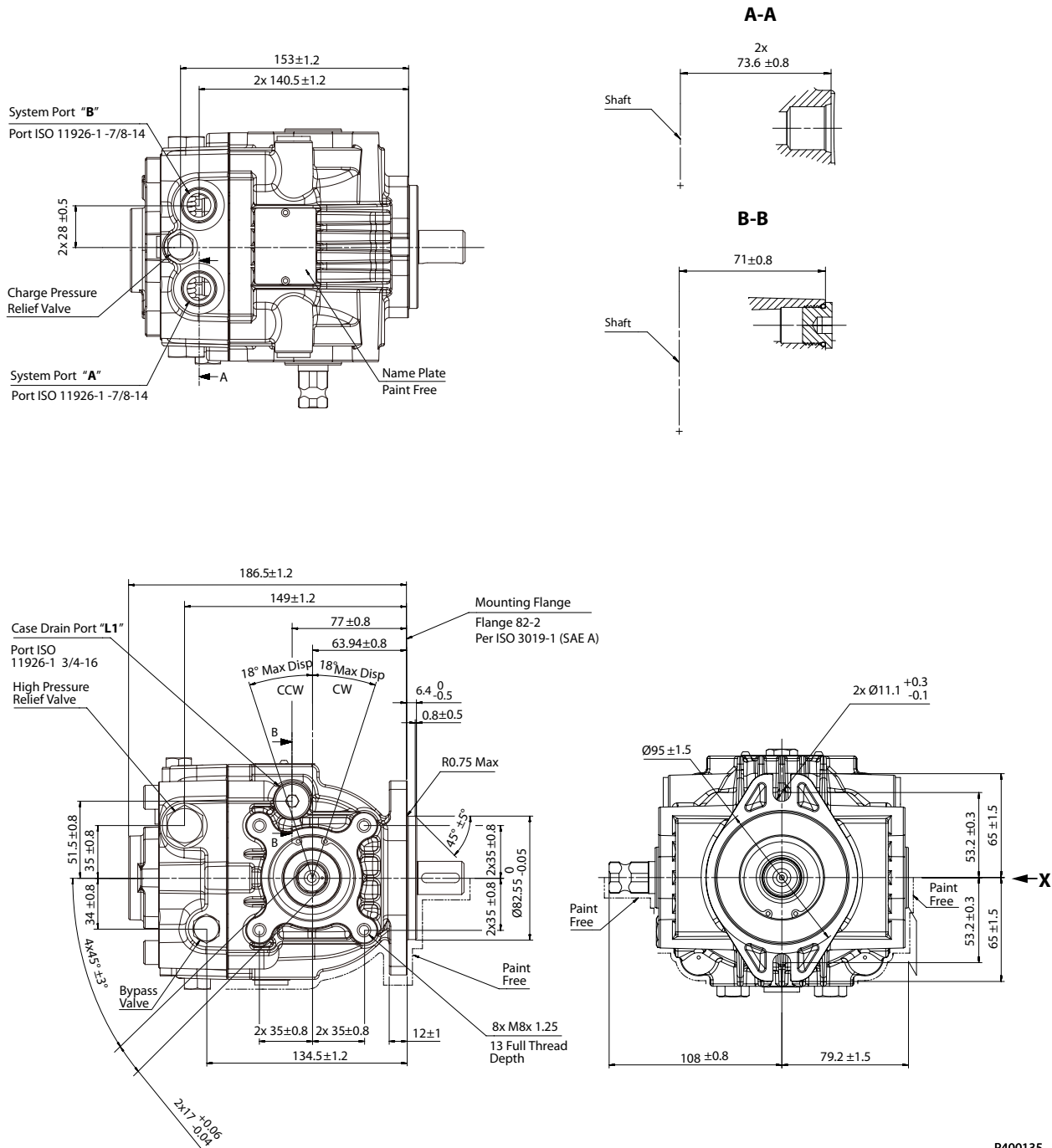

P400135

Installation Drawings

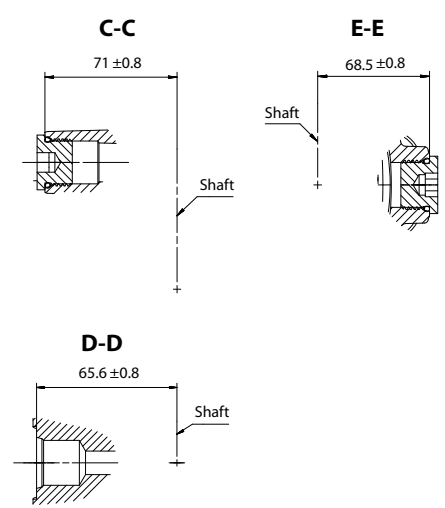
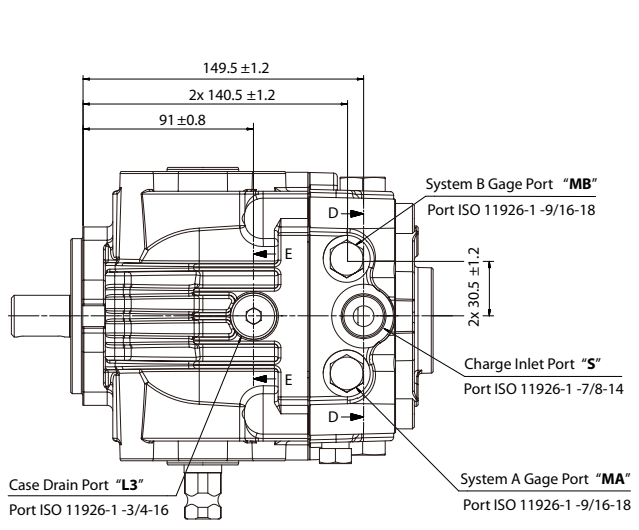
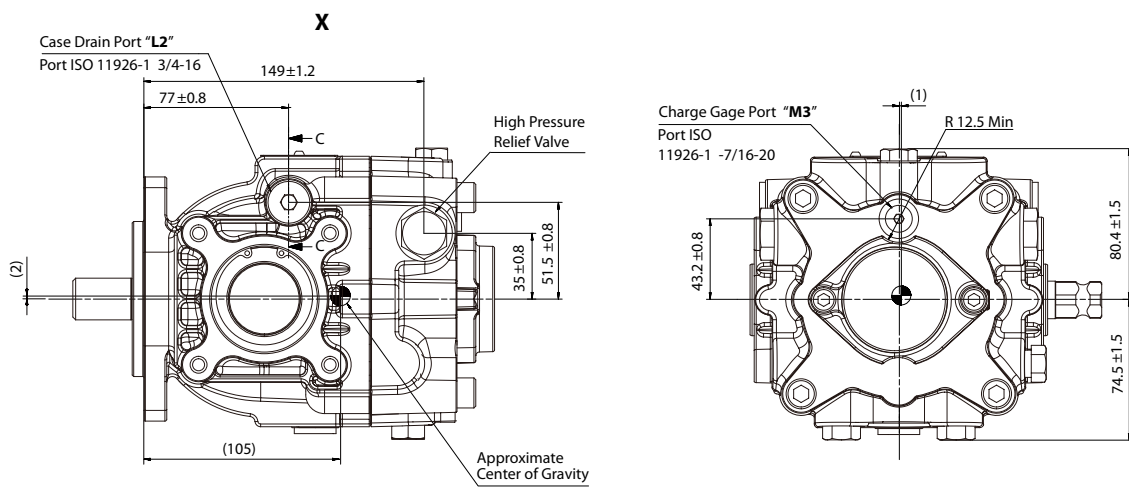

P400134

Installation Drawings

With Charge Pump, No Aux-Pad, Left Trunnion, SAE B Flange Configuration

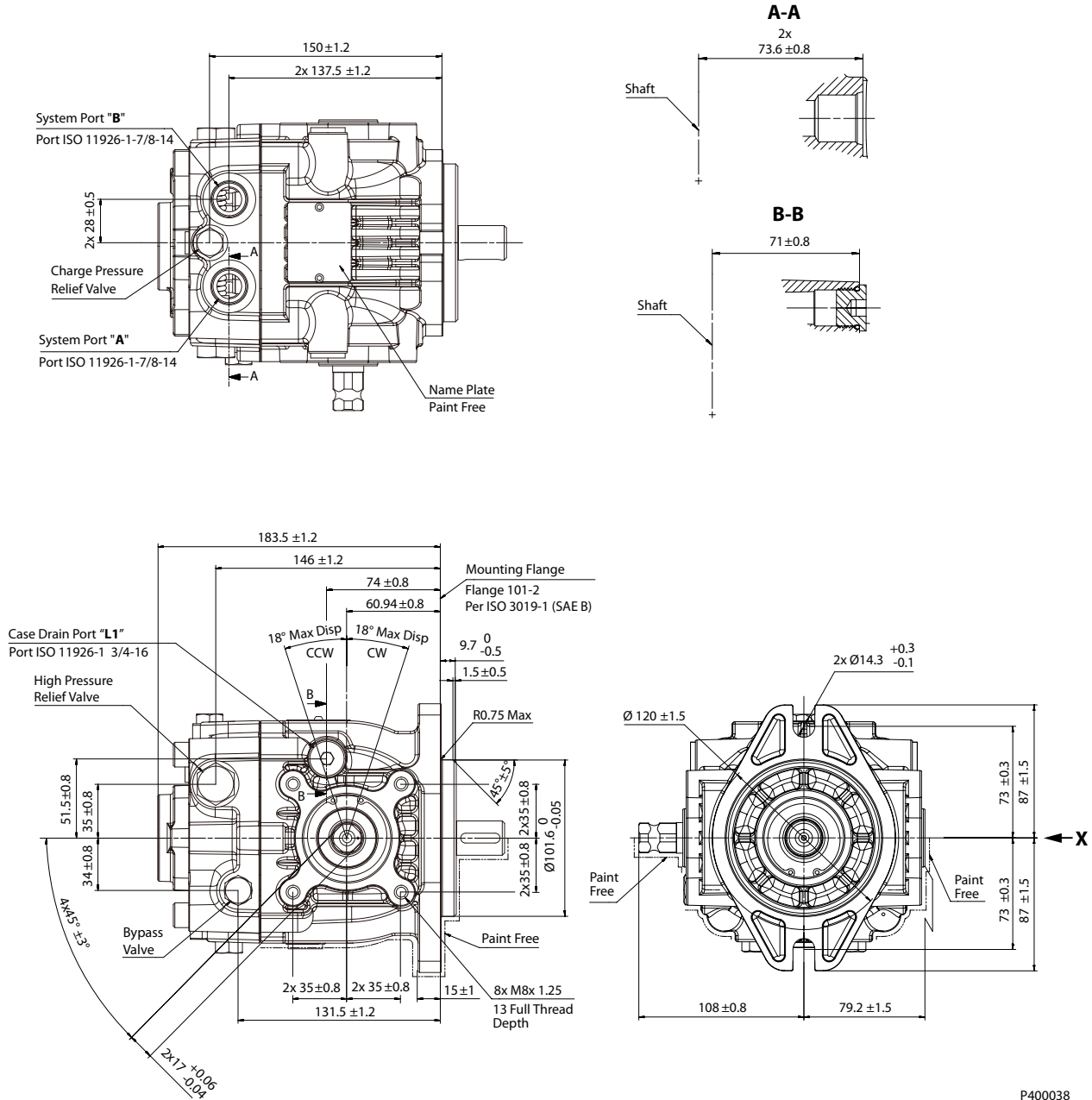

Installation Drawings

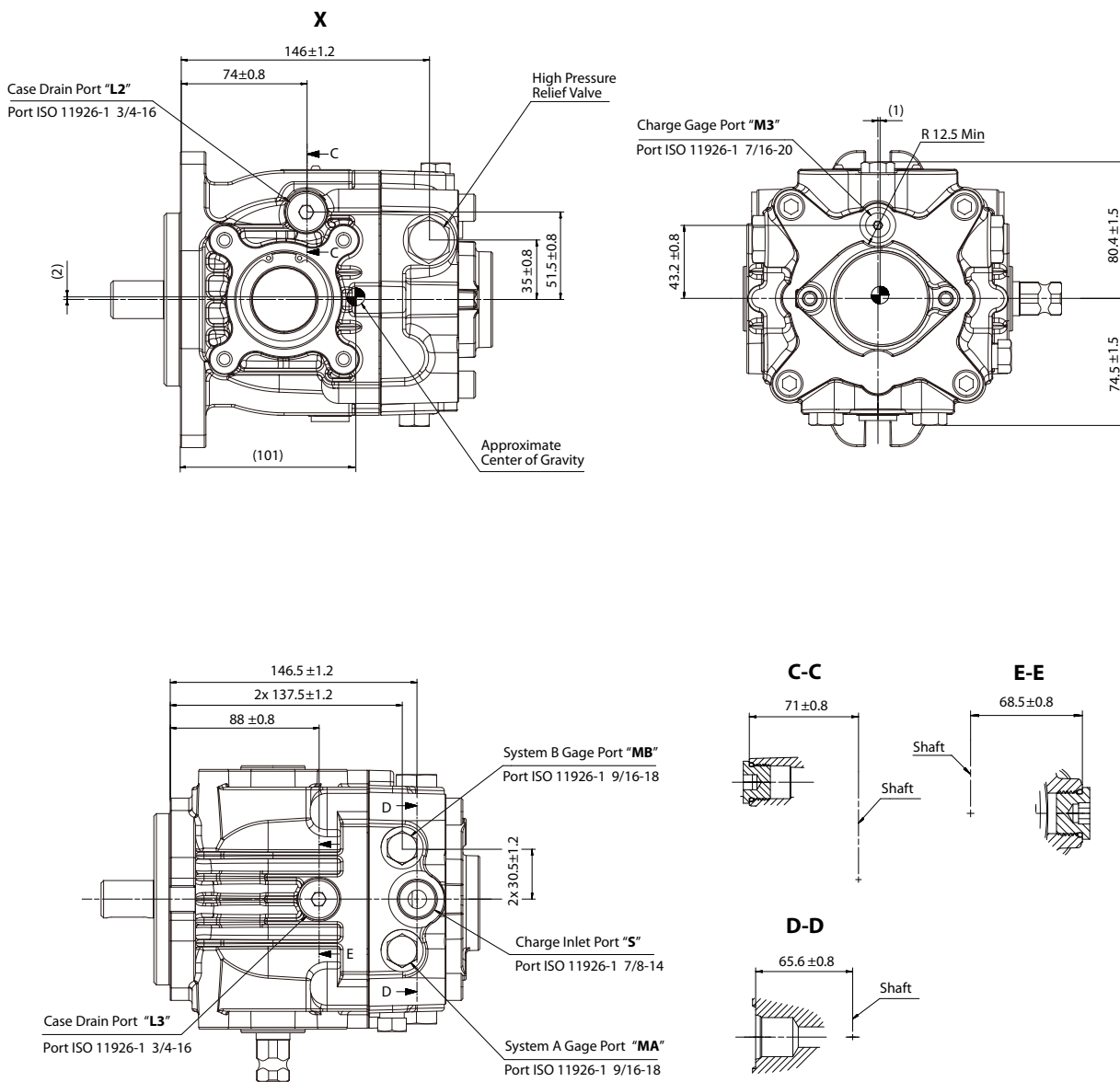

P400039

Installation Drawings

With Implement Pump, No Aux-Pad, Left Trunnion, SAE A Flange Configuration

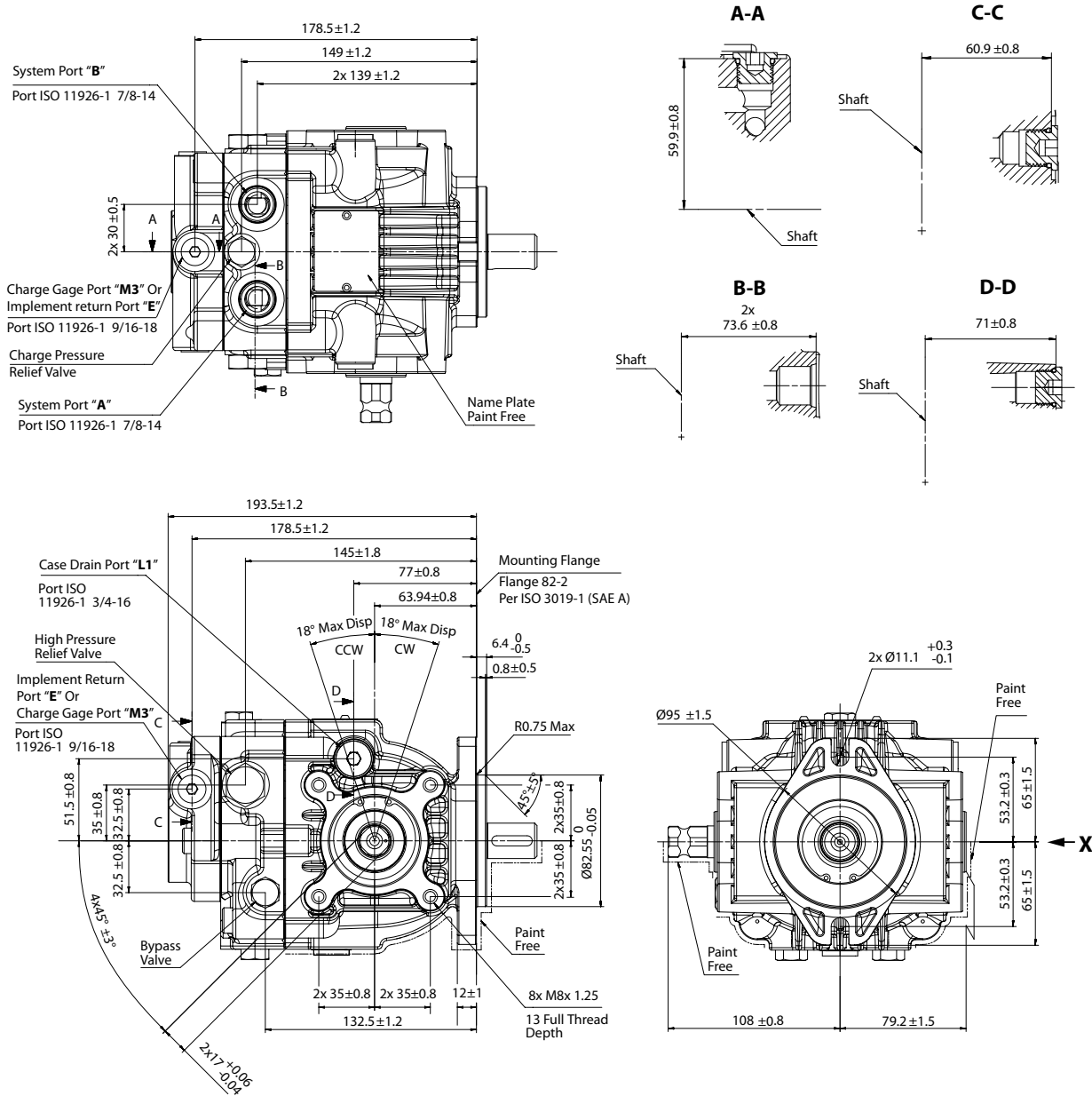

P400125

Installation Drawings

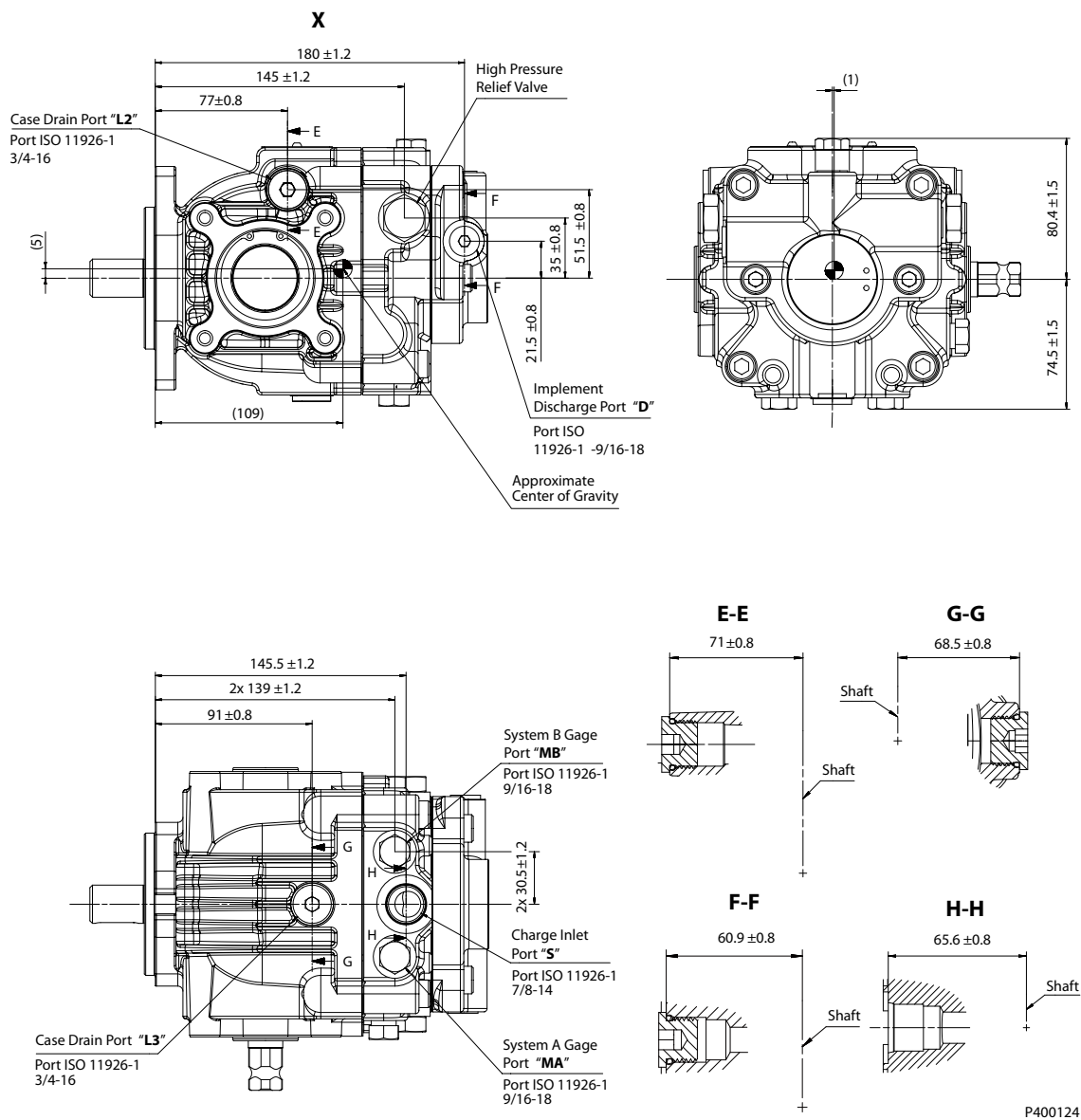

Installation Drawings

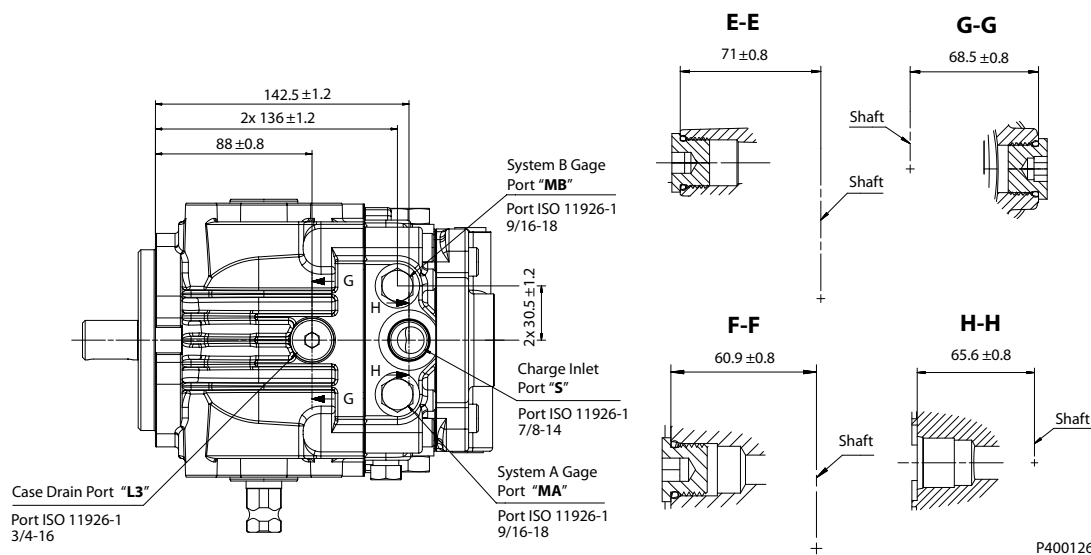
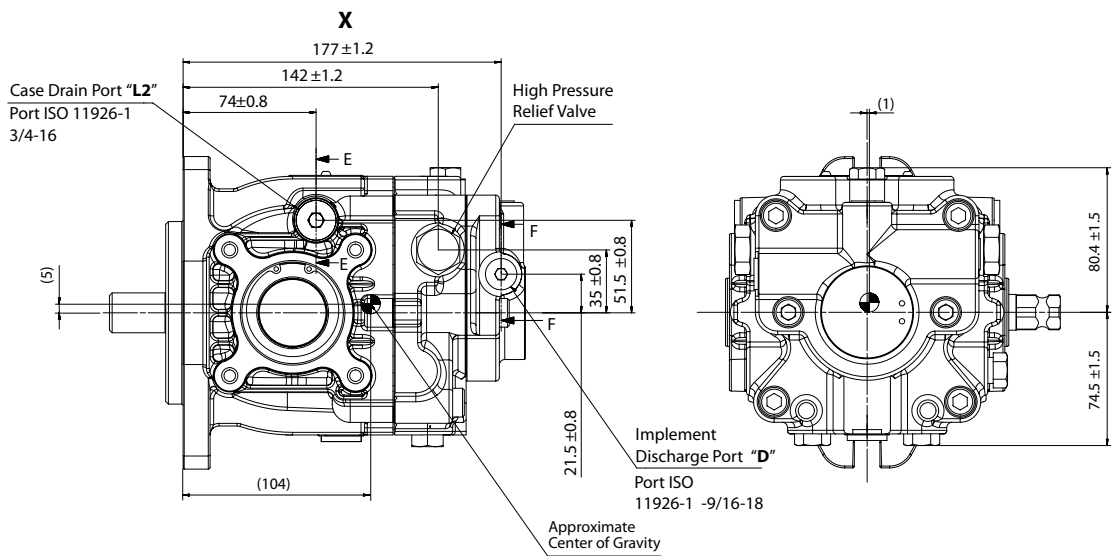

Installation Drawings

Input Shafts: AA, BA, DA

Shaft Availability and Torque Ratings

Option	Shaft Data	Torque Rating N·m [lbf·in]
		Maximum Torque
AA, BA, DA	Outer 0.875 inch dia, Straight key, 33mm	226 [2000]

SAE A

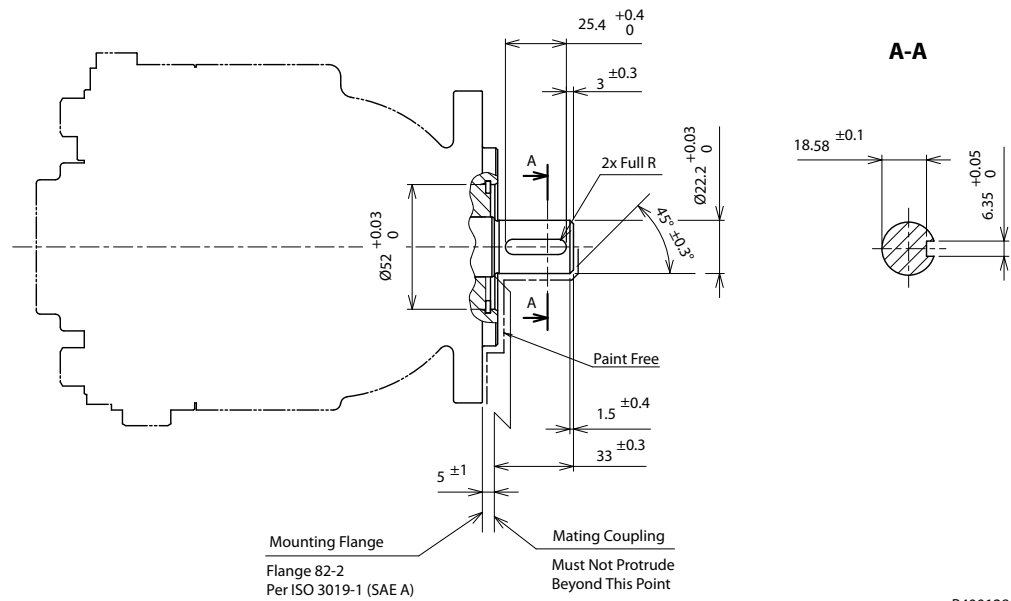

SAE B

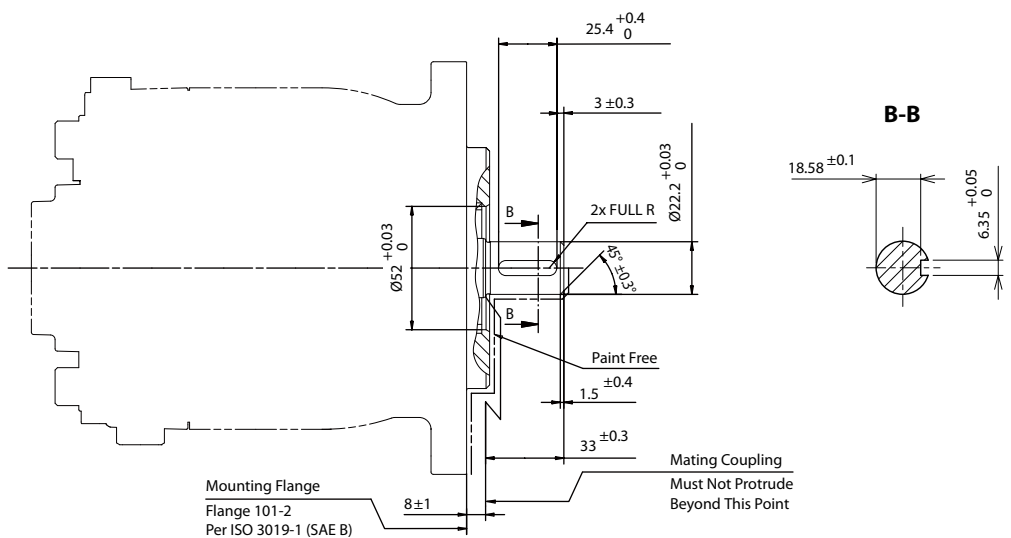

Installation Drawings

Input Shafts: AB, BB, DB

Shaft Availability and Torque Ratings

Option	Shaft Data	Torque Rating N·m [lbf·in]
		Maximum Torque
AB, BB, DB	Outer 0.875 inch dia, Straight key, 33mm	226 [2000]

SAE A

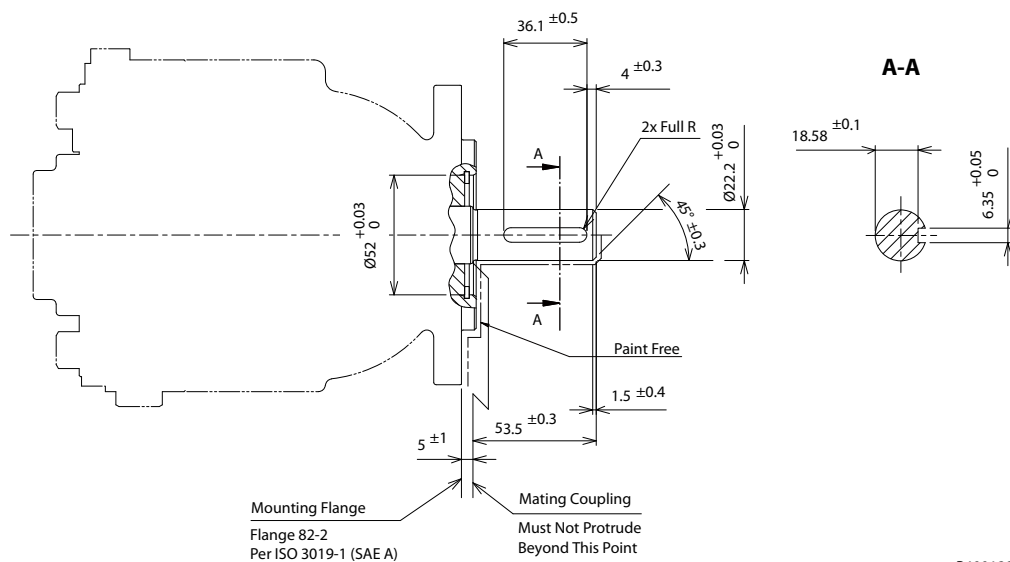

SAE B

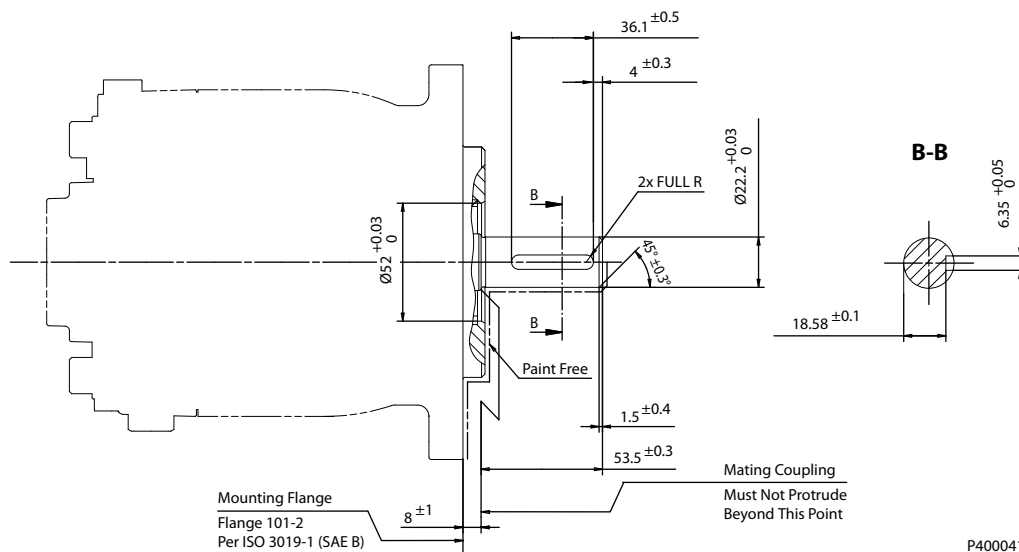

Installation Drawings

Input Shafts: AC, BC, DC

Shaft Availability and Torque Ratings

Option	Shaft Data	Torque Rating N·m [lbf·in]	
		Rated Torque	Maximum Torque
AC, BC, DC	13 teeth 16/32 pitch per ANSI B92.1-1970 CLASS5	180 [1593]	236 [2088]

SAE A

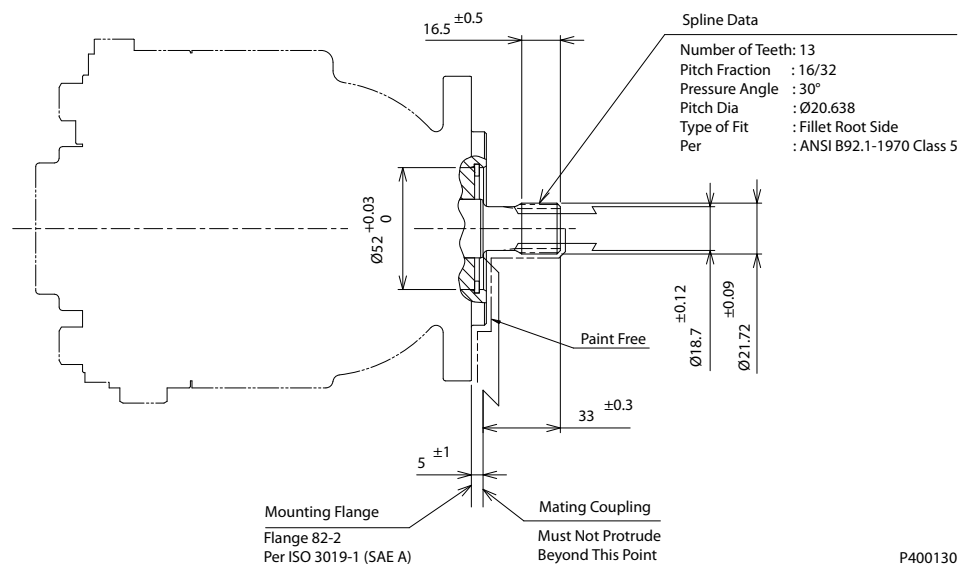

SAE B

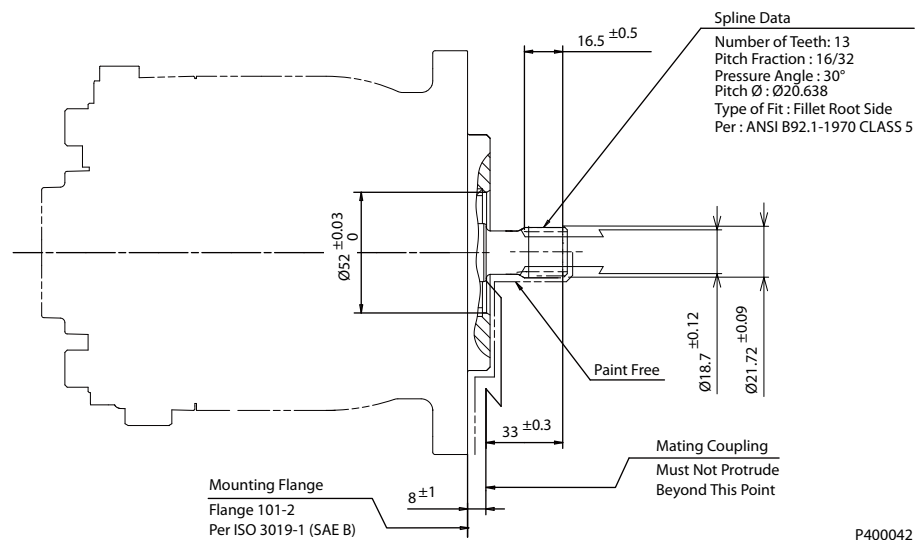

Installation Drawings

Auxiliary Mounting Pads

Shaft Availability and Torque Ratings

Pad Size	Flange	Spline	Minimum Spline Length mm [inch]	Maximum Torque N·m [lbf·in]
SAE A	ISO3019-1, flange82-2	9 teeth	13.5 [0.53]	162 [1434]
SAE A Special		11 teeth	13.5 [0.53]	194 [1717]
SAE A Special		13 teeth	13.5 [0.53]	207 [1823] ¹

¹ Limited by 23T aux spline.

9 teeth (option)

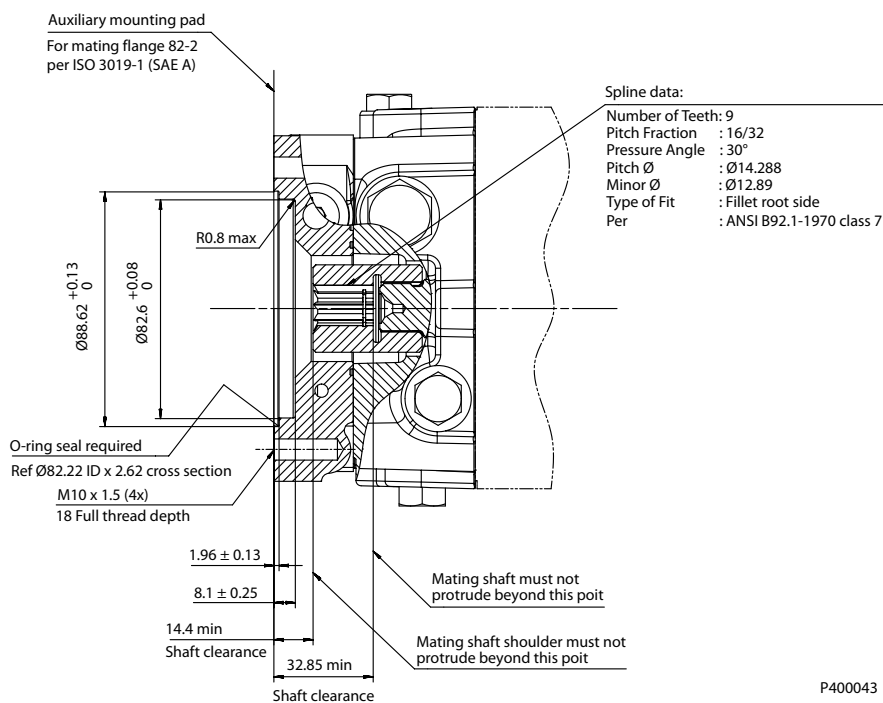

Installation Drawings

11 teeth (option)

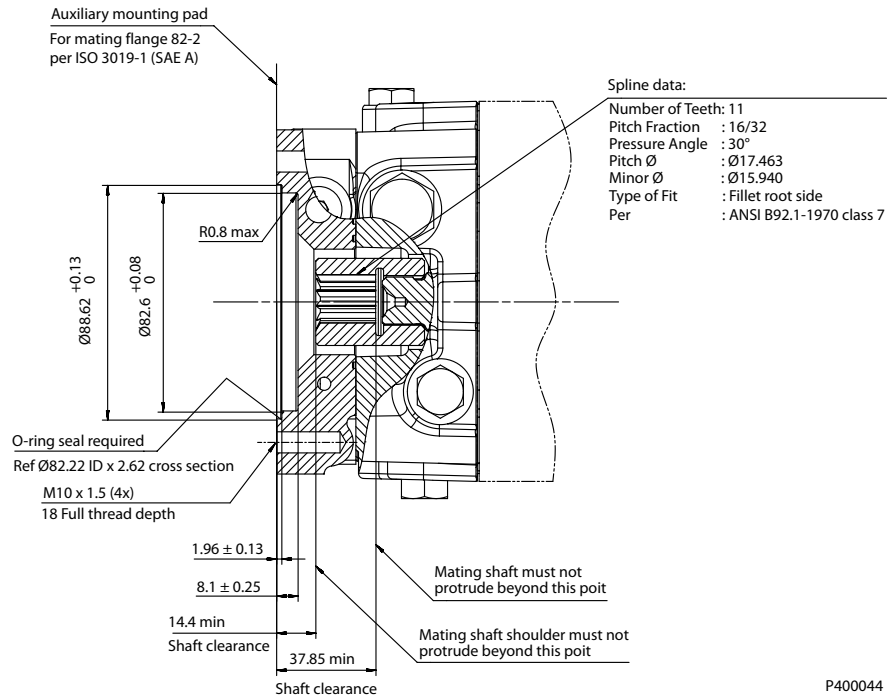

13 teeth (option)

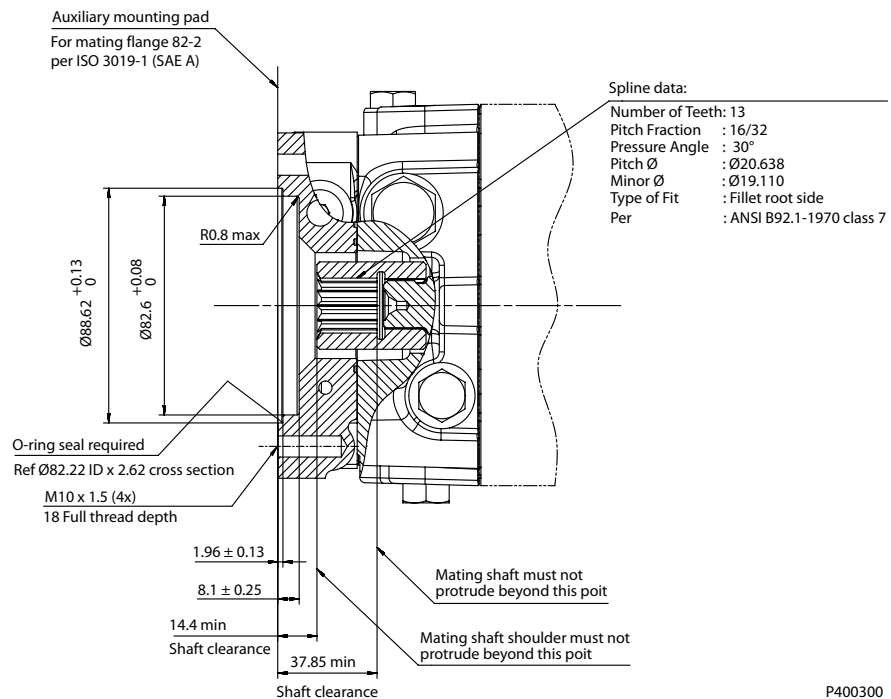

Reference Literature

Literature

Refer to the literature listed below for product information and specifications for DDC pumps and other Danfoss components.

DDC Pumps literature

- *DDC Axial Piston Pumps Service Manual* **AX152986482107**

Hydraulic Systems Guidelines

- *Hydraulic Fluids and Lubricants Technical Information* **BC152886484524**
- *Pressure and Speed Limits* **BC152886484313**
- *Design Guidelines for Hydraulic Fluid Cleanliness* **BC152886482150**
- *Experience with Biodegradable Hydraulic Fluids, Technical Information* **520L465**
- *Selection of Driveline Components* **BC157786484430**

Products we offer:

- Cartridge valves
- DCV directional control valves
- Electric converters
- Electric machines
- Electric motors
- Gear motors
- Gear pumps
- Hydraulic integrated circuits (HICs)
- Hydrostatic motors
- Hydrostatic pumps
- Orbital motors
- PLUS+1® controllers
- PLUS+1® displays
- PLUS+1® joysticks and pedals
- PLUS+1® operator interfaces
- PLUS+1® sensors
- PLUS+1® software
- PLUS+1® software services, support and training
- Position controls and sensors
- PVG proportional valves
- Steering components and systems
- Telematics

Danfoss Power Solutions is a global manufacturer and supplier of high-quality hydraulic and electric components. We specialize in providing state-of-the-art technology and solutions that excel in the harsh operating conditions of the mobile off-highway market as well as the marine sector. Building on our extensive applications expertise, we work closely with you to ensure exceptional performance for a broad range of applications. We help you and other customers around the world speed up system development, reduce costs and bring vehicles and vessels to market faster.

Danfoss Power Solutions – your strongest partner in mobile hydraulics and mobile electrification.

Go to www.danfoss.com for further product information.

We offer you expert worldwide support for ensuring the best possible solutions for outstanding performance. And with an extensive network of Global Service Partners, we also provide you with comprehensive global service for all of our components.

Local address:

Hydro-Gear

www.hydro-gear.com

Daikin-Sauer-Danfoss

www.daikin-sauer-danfoss.com

**Danfoss
Power Solutions (US) Company**
2800 East 13th Street
Ames, IA 50010, USA
Phone: +1 515 239 6000

**Danfoss
Power Solutions GmbH & Co. OHG**
Krokamp 35
D-24539 Neumünster, Germany
Phone: +49 4321 871 0

**Danfoss
Power Solutions ApS**
Nordborgvej 81
DK-6430 Nordborg, Denmark
Phone: +45 7488 2222

**Danfoss
Power Solutions Trading
(Shanghai) Co., Ltd.**
Building #22, No. 1000 Jin Hai Rd
Jin Qiao, Pudong New District
Shanghai, China 201206
Phone: +86 21 2080 6201

Danfoss can accept no responsibility for possible errors in catalogues, brochures and other printed material. Danfoss reserves the right to alter its products without notice. This also applies to products already on order provided that such alterations can be made without subsequent changes being necessary in specifications already agreed. All trademarks in this material are property of the respective companies. Danfoss and the Danfoss logotype are trademarks of Danfoss A/S. All rights reserved.