

Data Sheet

PLUS+1[®] Mobile Machine Displays

DP250 Series



Durable color display

Danfoss DP250 Series Displays are elements of the PLUS+1[®] family of mobile machine management products.

The DP250 series provide mobile machine OEMs with a range of rugged, high quality, cost effective color displays.

DP250 Series variants include several Input options, dual CAN port options and two USB options: a USB device mini-connector on the front of the display or a USB connector on the rear of the display.

Large function-programmable buttons provide tactile feedback. The high resolution color display is viewable in a wide range of lighting conditions. Backlight and contrast settings are programmable.

The DP250 display family features robust mechanical, electrical and environmental specifications that meet the harsh operating conditions found in mobile machine applications.



Features

- User-programmable with PLUS+1[®] GUIDE (Graphical User Integrated Development Environment)
- J1939 engine monitor (Engine Information Center) application software available (application keyed)
- High resolution color TFT display (240x320 pixels, 15-bit color)
- 6 software controlled LEDs (2 red, 2 amber, 2 green)
- 4 user-programmable soft keys
- 2 CAN 2.0 ports option
- 4 digital analog inputs options
- All models include 2 multifunction inputs (DIN/AIN/FrequencyIN/CurrentIN, 4–20 mA)
- 1 fixed-range analog input/CAN shield pin
- 16 MB program memory
- 16 MB application log memory option
- Real-time clock
- Buzzer output
- Two USB options:
 - Mini USB connector (USB device function) on the front of the display
 - Binder USB connector (USB function) on the back of the display
- IP 67 ingress rating
 - Exception: IP 54 rating for DP250 display with front mini-USB connector
- -30°C to 70°C (-22°F to 158°F) operating temperature range
- CE marked

Comprehensive technical literature online at powersolutions.danfoss.com

Dimensions

DP250 in mm[in]

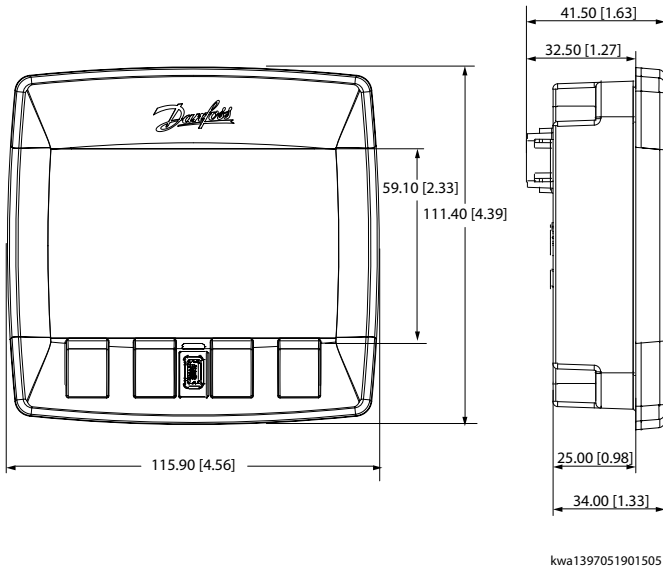

kwa1397051901505

Processor	ARM 7 core, 16/32 bit/ 72 MHz
RAM	64KB on-chip, 1MB on board
FRAM	16 KB
Supply Voltage	9–63 Vdc/6.5W
Current Consumption	Heater 10W
Connector	DEUTSCH DTM-12
LCD Glass	TFT with 15-bit resolution
Resolution	320 x 240 pixels
Viewable Area	70.08 mm x 52.56 mm [3.15 x 2.16]
IP Rating	IP67 or IP54
Operation Temperature	Code C00: –20 °C - +70°C [–4°F - +158°F] Code C01: –30 °C - +70°C [–22°F - +158°F]
Storage Temperature	–40 °C to +85°C [–40°F to +176°F]
Weight	250g [0.5lb]
Vibration/Shock	5g/ 50g
EMC/ESD	100V/m / 15kV

Mounting panel cutout in mm[in]

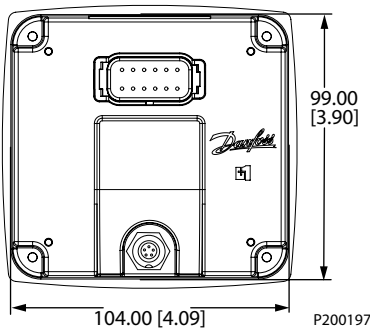

The DP250 front mini-USB model option carries an IP54 ingress rating. The USB cover/ plug must be in place for full IP54 protection. This model variant is recommended for in-cab installation only.

For full IP67 ingress rating of rear USB models, the cable or plug must be in place.



Binder Series 702 USB connector pin out information

1	Vbus
2	Data -
3	Data +
4	N/C
5	Ground
6	N/C
7	N/C
8	N/C

Specifications

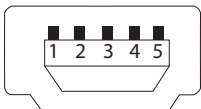

P200 129

USB mini-B connector pin out information

1	Vbus
2	Data -
3	Data +
4	Device ID (NC)
5	Ground

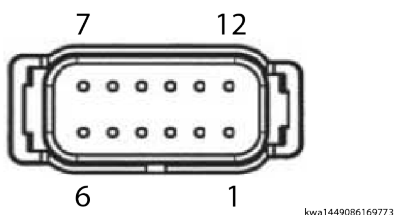

Use care when wiring mating connector. Diagrams show device pins.

DEUTSCH 12-pin connector pin out information

1	Power ground -
2	Power supply +
3	CAN 0 +
4	CAN 0 -
5	AIN/ CAN Shield
6	See Code B option/TI
7	See Code B option/TI
8	See Code B option/TI
9	See Code B option/TI
10	DIN/AIN/FREQ IN/CURRENT IN, RHEOSTAT
11	DIN/AIN/FREQ IN/CURRENT IN, RHEOSTAT
12	DOUT (0.5A)

Model features and Ordering information

A	B	C	D	E	F	Part number
DP250	00	00	04	00	00	11080686
	00	01	05	00	00	11075899 ¹
	01	01	04	05	00	11075900
	01	01	05	05	00	11077442 ²
	05	01	04	05	00	11060814
	05	01	05	05	00	11077443 ²
	06	01	04	05	01	11060816
	06	01	05	05	01	11077444 ²
	01	01	05	05	02	11094414 ²
	01	01	04	05	02	11091448

¹ EIC installed

² With app key which allows EIC SW installation

Accessory information

Model	Part number
DP2XX Panel Mounting Kit	11079236
DEUTSCH 12-pin Connector Kit (DTM06-12SA)	10100944
Binder Connector and Cable Kit (Series 702)	10103497

A: Model name

DP250	PLUS+1 [®] Mobile Machine Displays
--------------	---

B: Inputs/Outputs (All models have 2 multifunction)

00	1 CAN port
01	1 CAN port, 4 DIN/AIN
05	User Configurable: 2 CAN, 2 DIN/AIN or 1 CAN, 4 DIN/AIN
06	User Configurable: 1 RedCAN port, 1 CAN port or 1 RedCAN port, 2 DIN/AIN

C: Real Time Clock, low temperature functionality

00	No RTC and LTF
01	RTC and LTF

D: Flash Memory/Application Key

04	16MB without Application Key
05	16MB with Application Key

E: Application log

00	None
05	16MB

F: USB port type

00	None
01	USB Device in front
02	USB Device in rear

ENGINEERING
TOMORROW



Danfoss can accept no responsibility for possible errors in catalogues, brochures and other printed material. Danfoss reserves the right to alter its products without notice. This also applies to products already on order provided that such alterations can be made without changes being necessary in specifications already agreed.
All trademarks in this material are property of the respective companies. Danfoss and the Danfoss logotype are trademarks of Danfoss A/S. All rights reserved.
