

Data Sheet

PLUS+1[®] GUIDE

Take Control of Your Applications with PLUS+1[®] GUIDE!

GUIDE (Graphical User Integrated Development Environment) is a member of the PLUS+1[®] family of products that provide complete vehicle control solutions. Other PLUS+1[®] products include controllers, displays, and electrohydraulic products.

GUIDE allows graphical development of machine management applications, downloading of software via CAN, and development of user specific service and diagnostic tools. GUIDE maximizes OEM engineering productivity and protects intellectual property.

PLUS+1[®] GUIDE Development Tool

GUIDE uses graphic symbols and components to create application drawings that are easily understood by inexperienced programmers. The drawing represents the software application which is then automatically coded and serves as the documentation for the program.



Features

- Rapid production of applications enabled by dragging and dropping proven graphical software objects.
- Built on reliable, robust field-proven tools.
- Assures protection of proprietary intellectual property.
- Graphical editor allows easy development of applications by inexperienced programmers.
- PLUS+1[®] compliant function blocks increase productivity by allowing rapid set-up of Danfoss compliant sensor, pump, motor, and valve products.

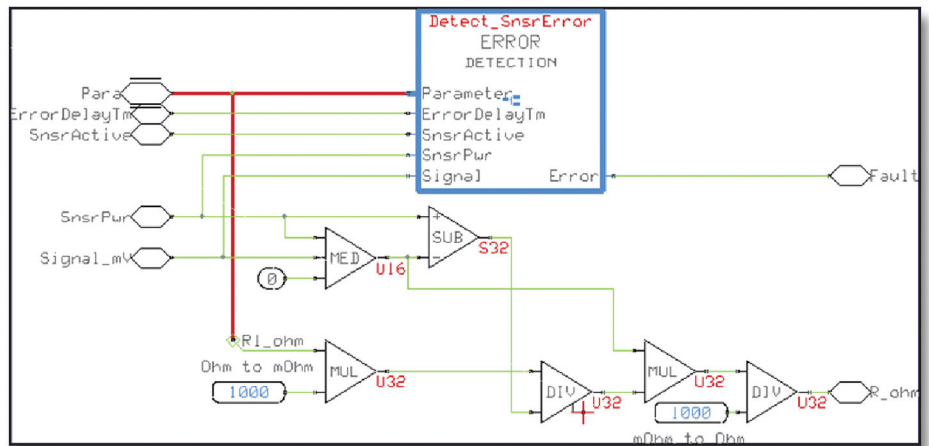

Comprehensive technical literature online
at powersolutions.danfoss.com



PLUS+1[®] GUIDE Development Tool

- Symbols and components are selected from a palette and dropped onto the drawing space.
- Danfoss developed function blocks are available for common control requirements such as PID control, ramp, filter, and command signal profiles.
- GUIDE compliance blocks allow rapid integration of input and output signals from Danfoss electrohydraulic products through the use of predetermined signal types and parameter default settings.
- Graphical programming reduces the number of steps required to develop an application; source code is generated directly from the application drawing to reduce coding errors.
- On-line and context-sensitive help allows easy comprehension of product features.
- Application data logging aids machine diagnostics.

Downloader

PLUS+1[®] includes an easy to use download feature. Application files are downloaded to the target controller via CAN. The download tool allows PLUS+1[®] users to access all of the controllers and intelligent modules on the PLUS+1[®] network. Simple, fast, reliable communications between a controller, or network of controllers, and a PC USB port is accomplished with the CG150 CAN/USB gateway.

System requirements

	Service Tool Minimum	GUIDE Minimum	GUIDE/Service Tool Recommended
CPU*	1.5 GHz, 32-bit (x86), 1 core, 2008 or later		3.0 GHz, 64-bit (x64), 4 cores, 2012 or later
OS**	32-bit Windows 7		64-bit Windows 7/8/8.1/10
UAC	Local Administrator Access		
RAM	1 GB		3 GB
HD	>1 GB Free, HDD		>2 GB Free, SSD
Resolution	1024 x 768		1920 x 1080
Email	For license registration		
PDF	Any recent standards compliant pdf reader		
XML	MSXML 4.0 Service Pack 2 (Microsoft XML Core Services)		
.Net	N/A		Version 4 (Full) is needed for PLC code support in GUIDE

* The CPU should be intended for at least laptop use. Processors designed for netbooks, tablets or similar are not recommended.

** This will be the last version that supports Windows 8. The next version will support Windows 7, 8.1 and 10.

Ordering information

Description	Part number
Library-Work Function	11179529
Library- Propel Application Library (Advanced)	11182154
Integration-Simulink S Function	11179531
PLUS+1 [®] GUIDE Professional	11179523
PLUS+1 [®] GUIDE Add-ons	11179525
PLUS+1 [®] Service Tool Add-ons	11179527

Related product

Description	Part number
CG150-2 CAN/USB Gateway Interface Communicator	11153051

Reference literature (on line at www.danfoss.com)

Title	Literature ID
PLUS+1 [®] GUIDE User Manual	10100824
PLUS+1 [®] Service Tool User Manual	L1307770
PLUS+1 [®] Service Tool Design Manual	L1320837