

Data Sheet

Joystick JS7000



Mobile Machine Management

The JS7000 joystick is an element of the family of mobile machine management products. The JS7000 is designed for heavy-duty operation and is highly qualified for the extreme and harsh environment conditions of the off-road mobile machine markets.

User Interface

The JS7000 has a patent pending left hand and right hand ergonomic grip design, which is specifically designed to create an easy, efficient, and enjoyable human-machine interaction. Along with superior comfort, easy access of push-button and trigger switches, and proportional grip function manipulation, productivity is maximized, one of the benefits that is quickly realized.

Reliable Performance

Dual Hall effect sensing technology ensures reliable long life performance for the most safety critical applications.

Serviceability

The JS7000 was designed around the consideration of serviceability to greatly reduce downtime. The grip functions and the boot are all serviceable.

Features

- Redundant Hall effect sensors
- Dual axis
- Two centering spring forces
- Operating life on each axis is greater than 15 million end of travel cycles
- On axis shaft, deflection options: $\pm 20^\circ$, or $\pm 25^\circ$
- Environmental IP (Ingress Protection) rating of 67 above and below the mounting with push-button and trigger configuration
- Integral 18 pin Deutsch® connector (DRC23-18SA)
- Vertical grip, left hand and right hand functions examples:
 - Up to seven momentary push-buttons plus trigger switch
 - Up to three proportional rollers or sliders, one momentary push-button switch, and one trigger switch
 - Up to five momentary push-buttons with red LED plus trigger switch
 - Up to two rocker switches plus trigger switch
- Unique ergonomic grip design features:
 - Ensures maximum productivity in all operating conditions
 - Quicker adaptability, especially for new and complex machines
 - Easy-to-use finger tip controls
 - Helps to minimize machine operator fatigue during long periods of use
- Designed, tested, and qualified for extreme mechanical stress conditions
- Serviceable for reduced down time

For more information and grip configuration examples, see Danfoss publication: *JS7000 Joystick Technical Information, L1125277.*

Dimensions and Pin Connections

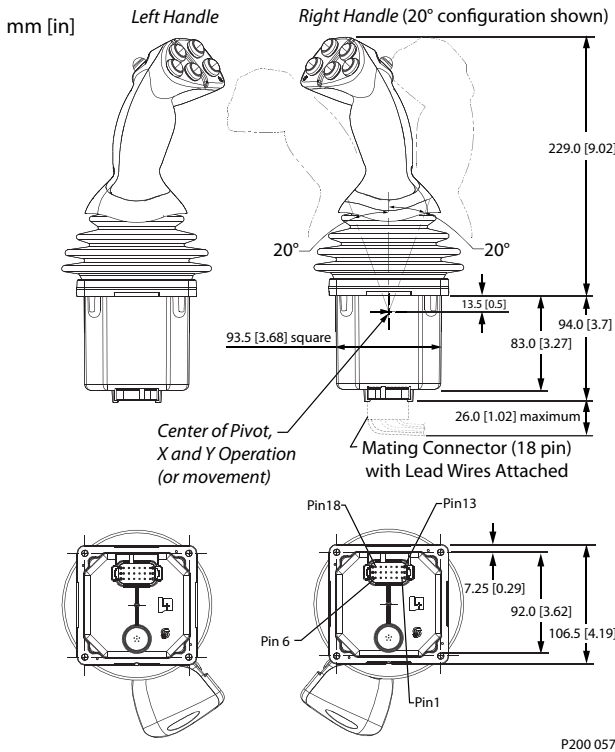

18 pin Deutsch® connector (DRC23-18SA)

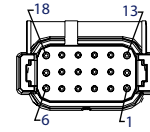

Pin	Signal name	Signal name	Signal name
1	Battery Ground	Battery Ground	Battery Ground
2	+5V	Battery Power	Battery Power
3	Proportional1*	CAN Hi	CAN Hi
4	Proportional2*	CAN Lo	CAN Lo
5	Proportional3*	CAN Shield	CAN Shield
6	Proportional4*	Not Connected	Digital Input 7
7	Digital1	Reference Ground	Sensor Ground
8	Digital2	Reference +5V	Sensor Power +5V
9	Digital3	Not Connected	Analog/Digital Input 1
10	Digital4	Not Connected	Analog/Digital Input 2
11	Digital5	Not Connected	Analog/Digital Input 3
12	Digital6	Not Connected	Analog/Digital Input 4
13	Digital7	Not Connected	Digital Input 1
14	Digital8	Not Connected	Digital Input 2
15	Proportional Y Axis 1	Proportional Y Axis 1	Digital Input 3
16	Proportional X Axis 1	Proportional X Axis 1	Digital Input 4
17	Proportional Y Axis 2	Proportional Y Axis 2	Digital Input 5
18	Proportional X Axis 2	Proportional X Axis 2	Digital Input 6

* Reference JS7000 Joystick Technical Information, L1125277.

Specifications

Electrical characteristics		
Sensor type	Hall Effect with redundant sensors	
Resolution	Analog: infinite	CAN: 2000 counts
Supply voltage (Vs)	Analog: 5 ± 0.5 Vdc	
	CAN with redundant analog outputs and CAN+: 9 to 60 Vdc	
Output	Analog: 0.5 to 4.5 Vdc	
	CAN: 2.0 B, J1939 and CANopen protocols	
	CAN+: 2.0 B, J1939 protocol	
Maximum current consumption (base without grip)	Analog: 45 mA	
	CAN: 120 mA at 9 V	
	CAN+: 100 mA at 9 V (without LEDs or sensor power)	
Mechanical characteristics		
Lever operating spring force	± 20° of travel	± 25° of travel
Medium (SM)	0.6 to 3.2 Nm	0.6 to 4.8 Nm
Heavy (SH)	1.1 to 4.2 Nm	1.1 to 5.8 Nm
Operating life (on each axis)	> 15 million cycles	
Vibration (random)	7.7 Grms	
Shock	50 G	
Weight (base without grip)	725 G (1.8 lb)	
Horizontal load maximum (125 mm from the pivot)	1335 N (300 lbs)	
Vertical load maximum	6000 N (1350 lbs)	

Environmental parameters	
Operating temperature	-40° C to 85° C (-40° F to 185° F)**
Storage temperature	-55° C to 85° C (-67° F to 185° F)**
Ingress protection (IP) rating	
Push-button and trigger configuration	IP 67 above and below mount
Proportional roller	IP 43 in cab use only
Proportional slider	IP 66 above and below mount
Slider switch	IP 66 above and below mount
Rocker switch	IP 68 above and below mount
EMI/RFI rating	150 V/m

** Does not apply to all rocker switch options.

Ordering Information	
Reference JS7000 Joystick Technical Information, L1125277	
Related product	Danfoss part number
Mating connector bag assembly	11012648
Mating connector with 400 mm (15.75 in) wire harness	11012646

Danfoss product literature is on line at: www.danfoss.com

Danfoss Power Solutions US Company
 2800 East 13th Street
 Ames, IA 50010, USA
 Phone: +1 515 239 6000

Danfoss Power Solutions GmbH & Co. OHG
 Krokamp 35
 D-24539 Neumünster, Germany
 Phone: +49 4321 871 0

Danfoss Power Solutions ApS
 Nordborgvej 81
 DK-6430 Nordborg, Denmark
 Phone: +45 7488 2222

Danfoss Power Solutions (Shanghai) Co. Ltd.
 Building #22, No. 1000 Jin Hai Rd
 Jin Qiao, Pudong New District
 Shanghai, China 201206
 Phone: +86 21 3418 5200

Danfoss can accept no responsibility for possible errors in catalogues, brochures and other printed material. Danfoss reserves the right to alter its products without notice. This also applies to products already on order provided that such alterations can be made without consequential changes being necessary in specifications already agreed. All trademarks in this material are property of the respective companies. Danfoss and the Danfoss logotype are trademarks of Danfoss A/S. All rights reserved.