

ENGINEERING  
TOMORROW



Technical Information

# PVG 100

## Proportional Valve Group

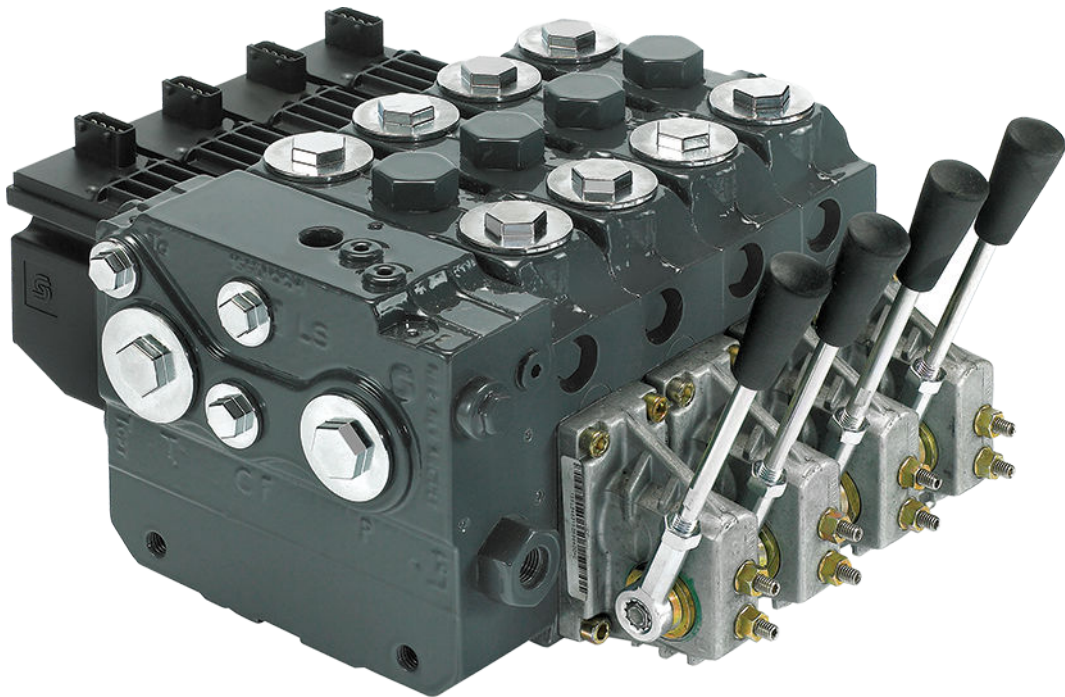

**Revision history**

*Table of revisions*

<b>Date</b>	<b>Changed</b>	<b>Rev</b>
September 2018	PVB 100 code numbers table change.	0503
May 2018	Minor change.	0502
March 2016	Updated for Engineering Tomorrow design.	0501
February 2006 - January 2014	Various changes	BA - EB
February 2005	New Edition	AA

## Contents

### General information

Acronyms.....	6
General.....	7
PVG 100 standard oil flow direction/max flow setting.....	7
PVG 100 valve system.....	7
General features PVG 100, load independent flow control.....	7
PVP - pump side module .....	8
PVB – basic module.....	8
Actuation module.....	8
Remote control units .....	9

### Function

PVG 100 with open center PVPF.....	10
PVG 100 with closed center PVPV / PVPVP / PVPVM.....	11
PVG 100 closed center priority steering PVPVP module .....	12
PVG 100 closed center PVPVM module .....	12
PVG 100 basic modules PVB.....	12
PVG 100 tank modules .....	13
Load sensing controls.....	14
LS control with bleed orifice (do not use with PVG valves).....	14
Integral PC function.....	14
Load sensing system characteristics:.....	14
Remote pressure compensated controls.....	15
Remote pressure compensated system characteristics:.....	15
PVG 100 main spool with pressure compensated control.....	15
Pressure compensated system characteristics.....	16
Typical applications for pressure compensated systems.....	16
Typical applications for remote pressure compensated systems:.....	16
PVMR, friction detent.....	17
PVMF, mechanical float position lock.....	17
PVBS, main spools for flow control (standard).....	17
PVBS, main spools for flow control (with linear characteristic).....	18

### Safety

Building in safety.....	19
FMEA (Failure Mode and Effect Analysis) IEC EN 61508.....	19
Hazard and risk analysis ISO 12100-1/14121.....	19
Example of a control system for manlift.....	20
Examples of wiring block diagram.....	21
Example of fault monitoring.....	23
PVG 32 – Mainly used in system with fixed displacement pumps.....	24
PVG 100 – Alternative LS dump or pilot supply disconnect.....	24
PVG 120 – Pump disconnect/block for variable pumps.....	24

### Technical data

PVG 100 technical data.....	25
PVH, hydraulic actuation.....	25
PVG 100 PVM operating force.....	26
PVG 100 PVE reaction time and oil consumption.....	26
PVEO power supply and consumption.....	27
PVEA, PVEH and PVES.....	27

### Technical characteristics

PVPF, pump side module.....	28
Open center flow rating.....	28
Closed center flow rating.....	28
PVG 100 pressure drop for PVB, basic module.....	29
PVB with pressure compensation, closed center PVP.....	30
PVHC characteristic - Spool stroke vs current.....	33

### Hydraulic systems

**Contents**

PVG 100 with variable displacement pump schematic example..... 34

Electrically actuated PVG 100, variable displacement pump, PVB 100 with integrated pilot operated check valves..... 34

Electrically actuated PVG 100/32, fixed displ. pump, PVB 100/32 with integrated pilot operated check valves..... 35

**Other operating conditions**

Oil.....36

    Mineral oil.....36

    Non-flammable fluids.....36

    Biodegradable oils.....36

Particle Content, Degree of Contamination.....36

Filtration.....36

**Mounting**

Standard mounting vs. option mounting.....38

**Modules and code numbers**

PVPF (Open Center) Inlet Modules - for Pumps with Fixed Displacement ..... 39

PVPF Accessories for Pump Side Modules..... 39

PVP (Open and Closed) Accessories for Pump Side Modules..... 40

PVPV (Closed Center) Inlet Modules..... 40

PVPVP, Closed Center Priority Side Modules - for Pumps with Variable Displacement..... 41

PVPVM, Closed Center Mid Inlet Modules - for Pumps with Variable Displacement..... 41

PVB 100 Basic Modules (Standard Spools)..... 42

PVB 100 Basic Modules (Exposed spools)..... 42

PVB 100 Basic Modules (High Flow Spools)..... 43

PVG 100 PVM code numbers..... 43

PVM / PVH, Covers..... 43

PVEO, ON/OFF Actuation..... 44

    PVHC - main spool control..... 44

PVEA/PVEH/PVES, Proportional Actuation..... 44

PVLA, Anti-Cavitation Valve Fitted into PVB..... 45

PVLP, Shock / Anti-Cavitation Valve Fitted into PVB..... 46

PVT 100, Tank Module..... 46

PVTI 100/32, Interface Module\*..... 47

PVG 100 PVSI / PVT, Assembly Kit..... 47

PVBE (End Bodies), Assembly Kit..... 47

PVG 100 / PVTI, Interface Module Assembly Kit..... 47

PVB 32, Assembly Kit..... 47

PVG 32 Basic Modules with T0, PVBZ (Compatible with PVG 100)..... 48

PVG 32 Basic Modules with T0, PVB (Compatible with PVG 100)..... 49

Standard Spools for Electrical and Mechanical Actuation Progressive Flow Characteristics..... 50

Standard Spools for Hydraulic Actuation Progressive Flow Characteristics..... 50

Spools for Friction Detent, PVMR (not compatible with PVBZ 100) Progressive Flow Characteristics..... 51

Spools for Mechanical Float position, PVMF (not compatible with PVBZ 100) Progressive Flow Characteristics..... 51

Standard Spools (Electrical and Mechanical Actuation) Linear Flow Characteristics..... 51

Standard Spools (Electrical and Mechanical Actuation) Throttled Open in Neutral, Linear Flow Characteristics..... 52

Standard Spools (Hydraulic and Mechanical Actuation), Throttled Open in Neutral, Linear Flow Characteristics..... 52

Standard Spools (Electrical and Mechanical Actuation), Full Open in Neutral; Progressive Flow Characteristics ..... 52

Standard Spools (Hydraulic and Mechanical Actuation), Full Open in neutral; Linear Flow Characteristics ..... 52

High Flow Spools (Electrical and Mechanical Actuation) Progressive Flow Characteristics..... 53

High Flow Spools (Hydraulic and Mechanical Actuation) Progressive Flow Characteristics..... 53

High Flow Spools, Full Open A/B → T and Neutral; Progressive Flow Characteristics ..... 54

Exposed spools Progressive Flow Characteristics..... 54

## Contents

### Dimensions

PVG 100 dimensions in general.....	55
PVG 100 with open center PVPF dimensions.....	56
PVG 100/32, closed center PVPV.....	57
PVG 100, Closed Center PVP with Integrated Priority Valve .....	58
Examples.....	59

### Module selection chart

Exploded view for module selection .....	64
--	----

### PVG 100 order specification

Please state.....	69
Standard and option assembly.....	69
Reordering.....	70

### Specification sheet

Specification form.....	71
Specification example for PVPVM.....	72

## General information

### Acronyms

This table provides a definition of some commonly used terms

<b>PVG = Proportional Valve Group</b>	
PVAS	Assembly (Tie Rod) Kit
PVB	Basic Module (Body)
PVBE	Basic End Module (Body)
PVBO	Basic Open Ended Module (Body)
PVBS	Main Spool for PVB
PVBSO	Main Spool for PVBO
PVBZ	Basic Module (Body) Zero Leak
PVE	Electrical Actuator
PVEA	Electrical Actuator-Fine Proportional
PVED	Electrical Actuator-Digital
PVEH	Electrical Actuator-High Proportional
PVEO	Electrical Actuator-ON/OFF
PVES	Electrical Actuator-Super Proportional
PVH	Cover for Hydraulic Actuation
PVHC	Electrical Actuator-High Current
PVLA	Anti-Cavitation Valve
PVLP	Shock Valve
PVM	Mechanical Actuator
PVMD	Cover for Mechanical Activation
PVMF	Cover for Mechanical Float
PVMR	Cover for Friction Detent
PVP	Pump Side Module (Inlet)
PVPC	Plug for external pilot oil supply
PVPD	Open Center PVPF Dummy Spool
PVPE	Electrical Unloading Valve for PVPF
PVPF	Open Center PVP
PVPH	Hydraulic Unloading Valve for PVPF
PVPP	Electrical Pilot Shut-Off Valve
PVPV	Closed Center PVP
PVPV/M	Pump side module
PVPVP	Closed Center PVP w/Priority
PVPX, LS	LS Unloading valve
PVT	Tank Side Module
PVTI	Interface Module

## General information

### General

#### PVG 100 standard oil flow direction/max flow setting

Adjustment screws are used to change the amount of oil flowing from ports P to B or P to A.

*PVM to the right of PVP*

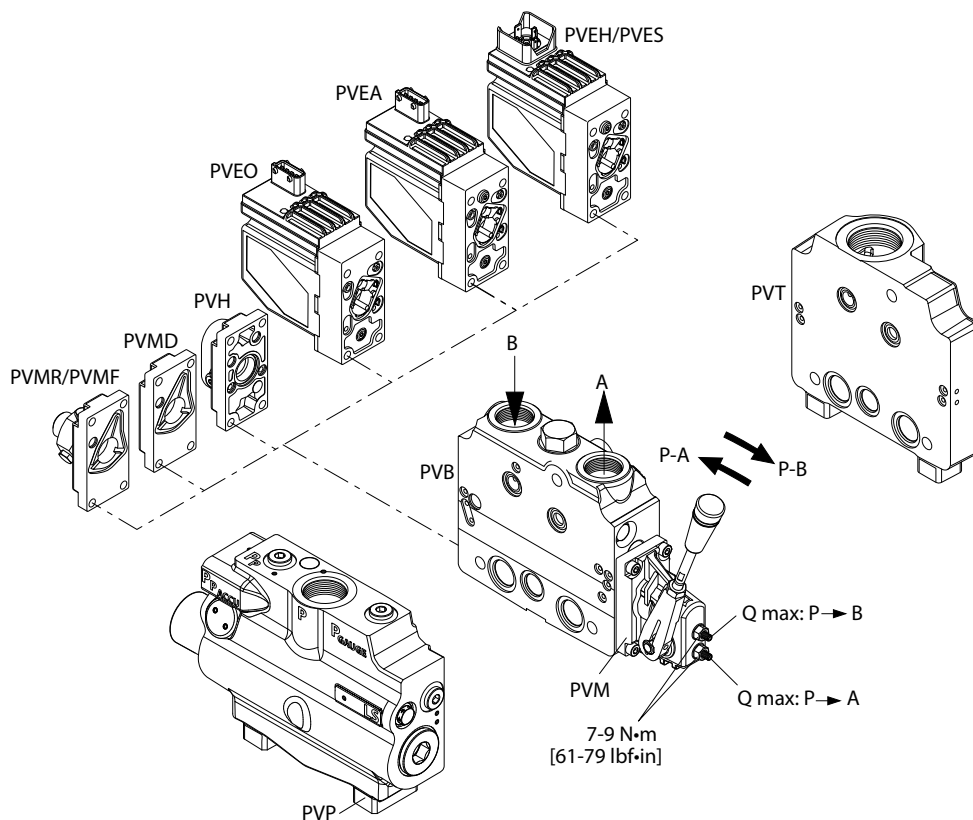

#### PVG 100 valve system

PVG 100 is a hydraulic load sensing valve, designed to fulfill efficiency requirements.

From a simple load sensing directional valve to an advanced electrohydraulic controlled load independent proportional valve the PVG 100 modular system makes it possible to build up a valve group to fulfill customer requirements. The compact external dimensions of the valve remain unchanged whatever combination is specified.

#### General features PVG 100, load independent flow control

- Flow sharing for maximum controllability and safety
- Load-independent flow control for precise operation and improved productivity
  - Oil flow to an individual function is independent of the load pressure of this function regardless of sufficient or insufficient pump flow.
  - Oil flow to one function is independent of the load pressure of other functions regardless of sufficient or insufficient pump flow.
- Load-sensing technology for higher efficiency, safety, reduced energy consumption, and longer system lifetime
- Configurable as an advanced electrical, hydraulic or mechanically operated proportional load-sensing valve
- Open spool-ends for system integrating mechanical cable or linkage actuation

**General information**

- Modular design providing a wide range of configuration possibilities
- Up to eight different sections per valve group (maximum flow per section: 240 l/min [63.4 gal/min])
- Can be configured in combination with PVG 32 (with T0) for maximum flexibility (up to 20 basic valve modules per valve group)
- Optimized return flow characteristics, which minimizes pressure loss
- Low weight
- Compact design and installation
- BSP and UNF connection threads

**PVP - pump side module**

- Build in load sense relief valve
- System pressure up to 350 bar (5075 psi)
- Full Flow dump valve (open center only)
- Pilot supply shut off (optional) ••Accumulator gauge connection
- Pressure gauge connection
- Pilot gauge connection
- Integrated pilot supply valve
- Versions:
  - Open center version for systems with fixed displacement pumps
  - Closed center versions for systems with variable displacement pump
  - Integrated priority valve for dynamic steering integration

**PVB – basic module**

- Integrated pilot operated check valves in A and B work ports for low internal leakage
- Integrated pressure compensator
- Interchangeable spools
- Single and Dual Shock/suction valves for A and B ports
- Different interchangeable spool variants
- All versions suitable for mechanical, hydraulic and electrical actuation
- Versions:
  - PVG100-HF (High Flow) version for less total pressure loss at increased flow
  - End module version for extra space savings
  - Open spool-end version for extended mechanical actuation possibilities

**Actuation module**

The basic module is always fitted with mechanical actuator PVM, which can be combined with the following as required:

- Electrical actuator (11 – 32 V<sub>AC/DC</sub>):
  - PVES – proportional, Super
  - PVEH – proportional, high performance
  - PVEH-F – proportional high performance, Float
  - PVEA – proportional low hysteresis (not recommended for PVG 100-HF High Flow)
  - PVEM – proportional, medium performance
  - PVEO – ON/OFF
  - PVEU – proportional, voltage control, 0-10 V



### General information

- PVED-CC – Digital CAN controlled J1939/ISOBUS
- PVED-CX – Digital CAN controlled CAN open extra vehicle system safety
- PVEP – PVM controlled (11-32 V)
- PVHC – High Current actuator for PVG
- PVMD, cover for Mechanical actuation
- PVMR, cover for Mechanical detent (not compatible with PO check modules)
- PVMF, cover for Mechanical Float (not compatible with PO check modules)
- PVH, cover for Hydraulic actuation.

### Remote control units

- Electrical remote control units:
  - PVRE, PVRET
  - PVREL
  - PVRES
  - Prof 1
  - Prof 1 CIP
  - JS120
  - JS1000 Ball grip
  - JS1000 PRO grip
  - JS2000
  - JS6000
  - JS7000
- Hydraulic remote control unit: PVRHH

### Electrical and hydraulic remote control units

PVRE, electrical control unit, 162F...

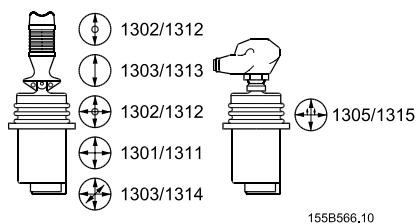

PVRH, hydraulic control unit, 155N...

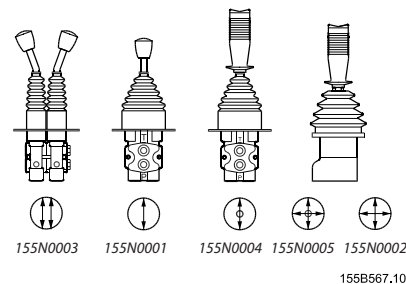

PVREL, electrical control unit, 155U...

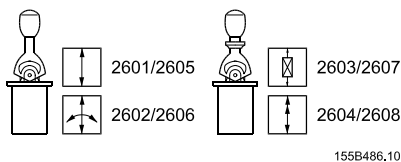

PVRES, electrical control unit, 155B...

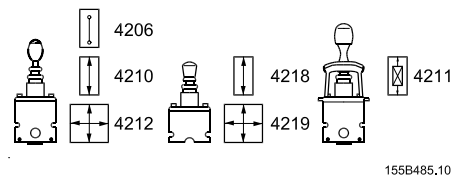

Prof 1, 162F...

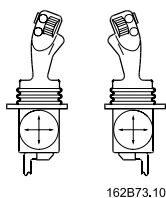

**Function****PVG 100 with open center PVPF**

When the pump is started and the main spools in the individual basic modules are in the neutral position, oil flows from the pump, through connection P, across the pressure matching spool (11) to tank. The oil flow led across the pressure matching spool determines the pump pressure (stand-by pressure).

When one or more of the main spools are actuated, the highest load pressure is fed through the shuttle valve circuit (4, 7) to the spring chamber (10) behind the pressure matching spool, and completely or partially closes the connection to tank. Pump pressure is applied to the opposite side of the pressure matching spool. The pressure relief valve (1) will open should the load pressure exceed the set value, diverting pump flow back to tank.

Optional PVPC with check valve option may be used in systems where it is necessary to operate the PVG 100 valve by means of the electrical remote control without pump flow.

For additional information about PVPC refer to the publication **520L0344**.

Optional electrically actuated pilot shut off valve PVPP provides additional functional system safety by removing pilot oil from the electrical actuation or hydraulic actuation system, disabling main spool actuation. When the PVPP is used with the PVBZ P.O. check valve system it is possible to disable actuation during mechanical actuation

**Function**

*PVG 100 sectional view PVP with open center*

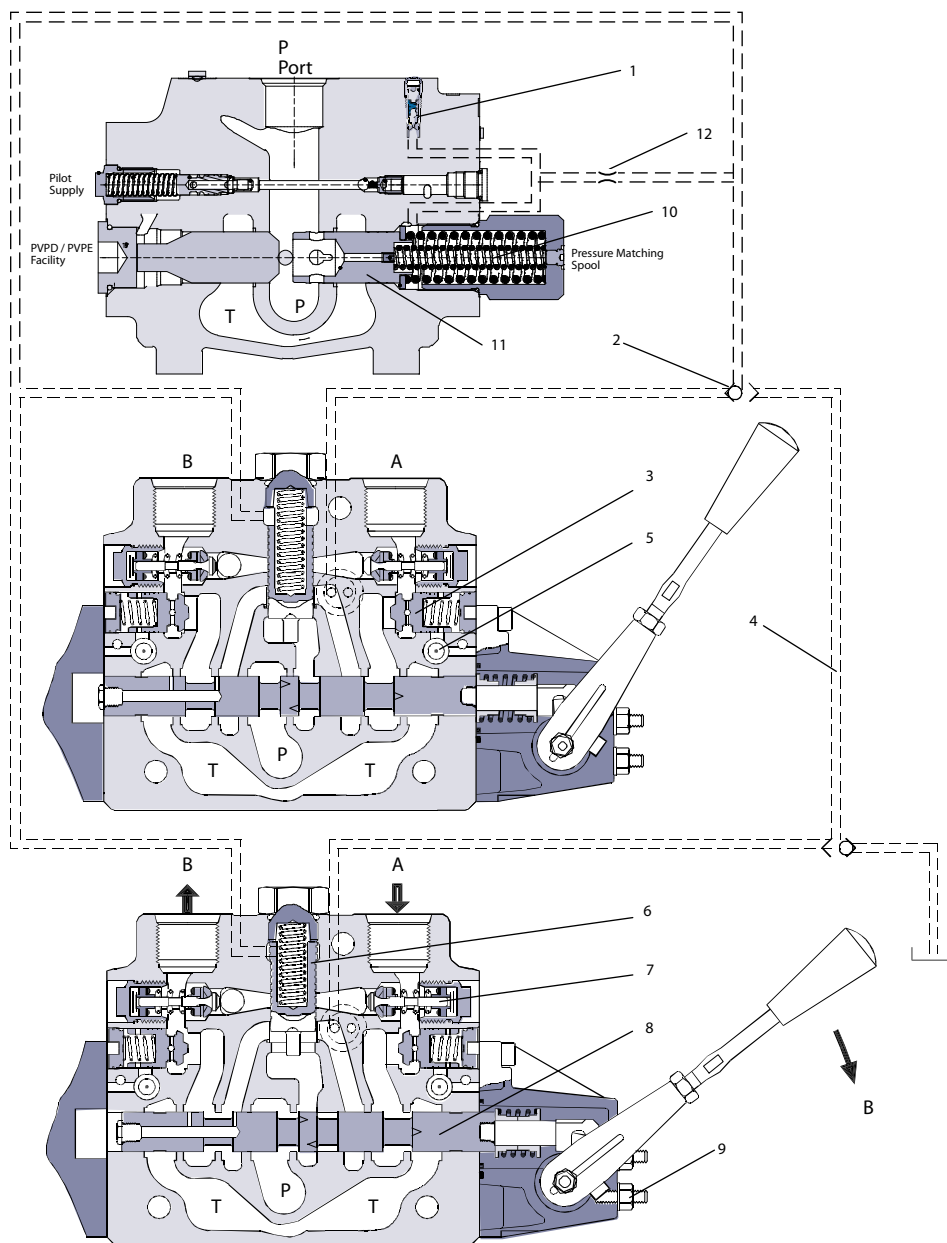

- |                                     |   |
|-------------------------------------|---|
| 1 – LS relief valve                 | 7 – Shock and suction valve, PVL P                    |
| 2 – Shuttle valve                   | 8 – Main spool, PVBS                                  |
| 3 – Pilot operated check valve, POC | 9 – Max. oil flow adjustment screws for ports A and B |
| 4 – LS line                         | 10 – Spring 12 or 20 bar                              |
| 5 – Logic cartridge for POC         | 11 – Pressure matching spool                          |
| 6 – Pressure compensator            | 12 – Orifice  |

**PVG 100 with closed center PVPV / PVPVP / PVPVM**

In load sensing systems the load pressure is led to the pump control via the LS connection (2 in the diagram below). When the work functions are in the spring neutral position the LS pressure is drained to

## Function

tank via the PVG valve. In this condition the pump control sets the displacement so that leakage in the system is compensated for, to maintain the set stand-by pressure (pump margin). When a main spool is actuated the pump control will adjust the displacement so that the set differential pressure between P and LS is maintained.

The PVG100 Inlet LS relief valve (1) is specifically designed to ensure a constant margin pressure across the main spool, providing demanded regulated flow during maximum load pressure conditions. This relief adjustment is critical when there are two or more functions being operated together. An incorrectly adjusted Inlet relief could result in a vast reduction in regulated flow from the adjacent functions that operate at a lower load pressure. To accurately adjust the inlet LS relief, the pump standby pressure must be known in addition to the maximum operating load pressure.

### Example

Pressure comp pressure level	172 bar [2500 psi]
LS standby pressure requirement that delivers the desired flow	-20 bar [-290 psi]
Maximum load pressure requirement	152 bar [2210 psi]
Inlet relief pressure setting	152 bar [2210 psi]

Optional PVPC with check valve option may be used in systems where it is necessary to operate the PVG 100 valve by means of the electrical remote control without pump flow.

For additional information about PVPC refer to publication 520L0344.

Optional electrically actuated pilot shut off valve PVPP provides additional functional system safety by removing pilot oil from the electrical actuation or hydraulic actuation system, disabling main spool actuation. When the PVPP is used with the PVBZ P.O. check valve system it is possible to disable actuation during mechanical actuation.

### **PVG 100 closed center priority steering PVPVP module**

The priority steering version of the PVPV will accommodate pump flows up to 250 l/min [66 US gal/min] and Control Flow (CF) up to 60 l/min [16 US gal/min] for dynamic steering systems. Additional return port is included with the PVPVP module.

### **PVG 100 closed center PVPVM module**

The mid-inlet version of the PVPV will accommodate pump flows up to 400 l/min [106 US gal/min] providing greater efficiency and flexibility when combined with standard and high flow work function modules.

## **PVG 100 basic modules PVB**

In the pressure-compensated basic module the compensator (9) maintains a constant pressure drop across the main spool (11) - both when the load changes and when a module with a higher load pressure is actuated.

Besides independent flow the other advantage of post-compensated work sections is the ability to control multifunction operation when flow demand exceeds pump capacity. This means that all work sections will continue to function regardless of differences in their load and regardless of the pump flow. The flow relationships specified between functions will be maintained over the full flow range of the pump.

The shock valves PVLV (10) with fixed setting and the suction valves PVLA on ports A and B are used for the protection of the individual working function against intermittent pressure overload and/or cavitation. Optional facilities for dual shock valves for ports A and B provide extra passage area reducing pressure drop for anti-cavitation applications.

Pilot operated check valve system PVBZ option (6, 8) on ports A and B are used to reduce the work port to tank leakage eliminating the need for external actuator load holding in non-critical load holding applications. All PVG 100 modules contain an integrated T0 drain system to insure optimal performance

**Function**

for PVBZ and all electrical actuation offerings. T0 is most effective when connected directly to the hydraulic system reservoir independent of the main Tank return system.

**PVG 100 tank modules**

Designed for low pressure drop at high return flows all PVT modules include facilities for PVLP shock valves insuring pressure passage spike protection during pump starvation recovery.

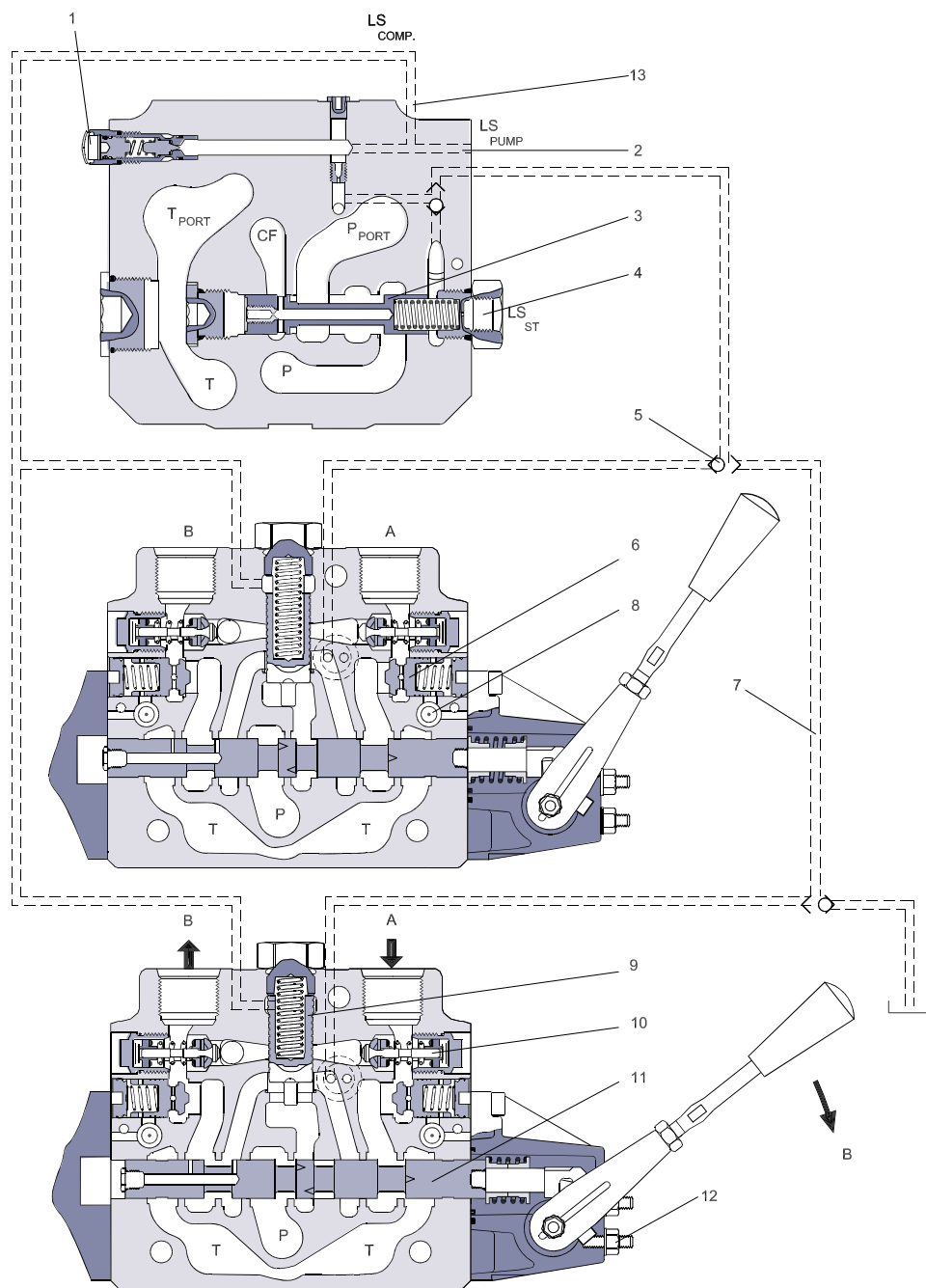

- |                     |                             |
|---------------------|-----------------------------|
| 1 – LS relief valve | 8 – Logic cartridge for POC |
| 2 – LS connection   | 9 – Pressure compensator    |

## Function

- |                                     |  |
|-------------------------------------|--|
| 3 – Priority spool for CF           | 10 – Shock and suction valve, PVLP                     |
| 4 – LS connection for steering unit | 11 – Main spool, PVBS                                  |
| 5 – Shuttle valve                   | 12 – Max. oil flow adjustment screws for ports A and B |
| 6 – Pilot operated check valve, POC | 13 – LS comp (LS signal sent back to compensators)     |
| 7 – LS line                         |  |

## Load sensing controls

The LS control matches system requirements for both pressure and flow in the circuit regardless of the working pressure. Used with a closed center control valve, the pump remains in low-pressure standby mode with zero flow until the valve is opened. The LS setting determines standby pressure.

*Typical operating curve*

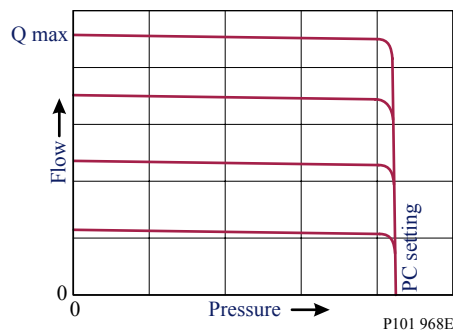

*Load sensing circuit*

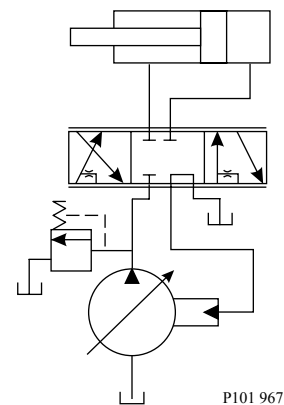

Most load sensing systems use parallel, closed center, control valves with special porting that allows the highest work function pressure (LS signal) to feed back to the LS control.

*Margin pressure* is the difference between system pressure and the LS signal pressure. The LS control monitors margin pressure to read system demand. A drop in margin pressure means the system needs more flow. A rise in margin pressure tells the LS control to decrease flow.

### **LS control with bleed orifice (do not use with PVG valves)**

The load sense signal line requires a bleed orifice to prevent high-pressure lockup of the pump control. Most load-sensing control valves include this orifice. An optional internal bleed orifice is available, for use with control valves that do not internally bleed the LS signal to tank.

### **Integral PC function**

The LS control also performs as a PC control, decreasing pump flow when system pressure reaches the PC setting. The pressure compensating function has priority over the load sensing function.

[For additional system protection, install a relief valve in the pump outlet line.](#)

### **Load sensing system characteristics:**

- Variable pressure and flow
- Low pressure standby mode when flow is not needed
- System flow adjusted to meet system requirements

## Function

- Lower torque requirements during engine start-up
- Single pump can supply flow and regulate pressure for multiple circuits
- Quick response to system flow and pressure requirements

### Remote pressure compensated controls

The remote PC control is a two-stage control that allows multiple PC settings. Remote PC controls are commonly used in applications requiring low and high pressure PC operation.

*Typical operating curve*

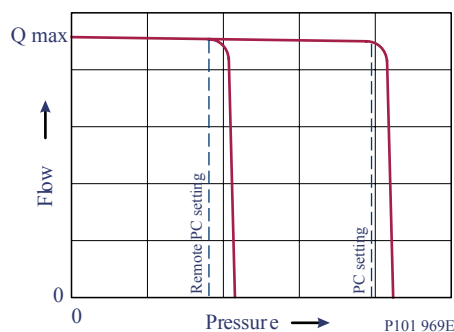

*Closed center circuit with remote PC*

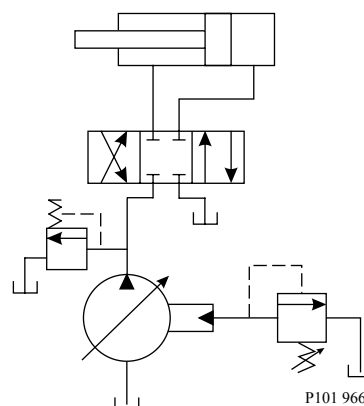

The remote PC control uses a pilot line connected to an external hydraulic valve. The external valve changes pressure in the pilot line, causing the PC control to operate at a lower pressure. When the pilot line is vented to reservoir, the pump maintains pressure at the load sense setting.

When pilot flow is blocked, the pump maintains pressure at the PC setting. An on-off solenoid valve can be used in the pilot line to create a low-pressure standby mode. A proportional solenoid valve, coupled with a microprocessor control, can produce an infinite range of operating pressures between the low pressure standby setting and the PC setting.

[Size the external valve and plumbing for a pilot flow of 3.8 l/min \[1 US gal/min\]. For additional system protection, install a relief valve in the pump outlet line.](#)

#### Remote pressure compensated system characteristics:

- Constant pressure and variable flow
- High or low pressure standby mode when flow is not needed
- System flow adjusts to meet system requirements
- Single pump can provide flow to multiple work functions
- Quick response to system flow and pressure requirements

### PVG 100 main spool with pressure compensated control

The PC control maintains constant system pressure in the hydraulic circuit by varying the output flow of the pump. Used with a closed center control valve, the pump remains in high pressure standby mode at the PC setting with zero flow until the function is actuated.

## Function

*Typical operating curve*

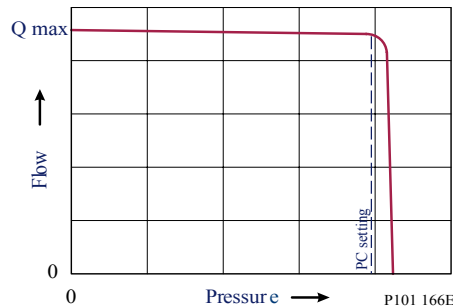

*Simple closed-center circuit*

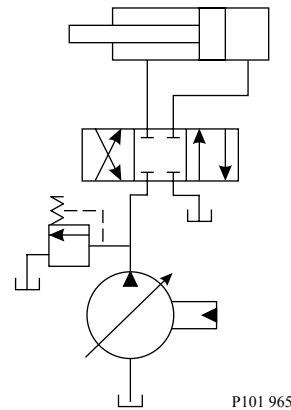

Once the closed center valve is opened, the PC control senses the immediate drop in system pressure and increases pump flow by increasing the swashplate angle.

The pump continues to increase flow until system pressure reaches the PC setting. If system pressure exceeds the PC setting, the PC control reduces the swashplate angle to maintain system pressure by reducing flow.

The PC control continues to monitor system pressure and changes swashplate angle to match the output flow with the work function pressure requirements.

If the demand for flow exceeds the capacity of the pump, the PC control directs the pump to maximum displacement. In this condition, actual system pressure depends on the actuator load.

For additional system protection, install a relief valve in the pump outlet line. \* Do not use the PVG 32 with bleed down load sense control.

### **Pressure compensated system characteristics**

- Constant pressure and variable flow
- High pressure standby mode when flow is not needed
- System flow adjusts to meet system requirements
- Single pump can provide flow to multiple work functions
- Quick response to system flow and pressure requirements

### **Typical applications for pressure compensated systems**

- Constant force cylinders (bailers, compactors, refuse trucks)
- On/off fan drives
- Drill rigs
- Sweepers
- Trenchers

### **Typical applications for remote pressure compensated systems:**

- Modulating fan drives
- Anti-stall control with engine speed feedback
- Front wheel assist



## Function

- Road rollers
- Combine harvesters
- Wood chippers

### PVMR, friction detent

The friction detent PVMR allows the directional spool to be held in any position, resulting in infinitely variable, reversible, pressure compensated flow.

This can be sustained indefinitely without having to continue to hold the mechanical lever. Friction detent spool position may be affected by high differential actuator flow forces and system vibration resulting in work function flow reduction.

*PVMR, friction detent*

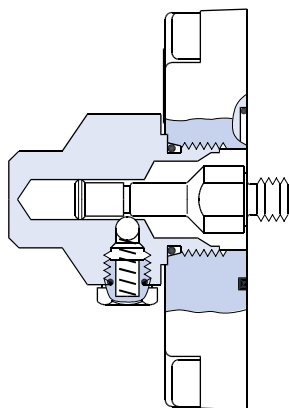

### PVMF, mechanical float position lock

Allows the float spool to be held in the float position after release of the mechanical handle.

*PVMF, standard mount only*

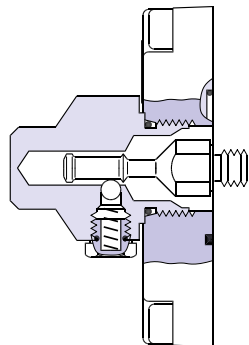

157-205.10

P → A → F (Push-in)

*PVMF, optional mount only*

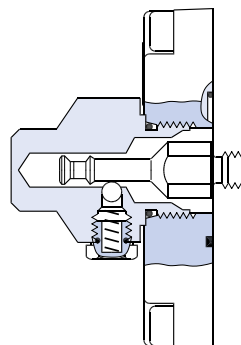

157-206.10

P → A → F (Pull-out)

### PVBS, main spools for flow control (standard)

With post-compensated valves, the A and B work port flow will depend on the pressure drop across the main spool PVBS.

In open center systems, this pressure drop (standby-pressure) is determined by the volume of fixed pump flow led to tank across the pressure adjusting spool in the inlet PVPF and the pressure adjusting spool

**Function**

bias spring pressure. Since the pressure drop varies with pump flow volume led to tank, the A and B work port flow will vary.

In closed center systems, the pressure drop across the main spool equals the standby setting of the pump, measured at the P-port of the valve. The A and B work port flow will remain unchanged as long as the standby is unchanged.

**PVBS, main spools for flow control (with linear characteristic)**

PVBS main spools with linear characteristic deliver a higher flow gain directly proportional to the linear spool travel beyond the dead band.

## Safety

### Building in safety

All makes and all types of control valves (including proportional valves) can fail. Thus the necessary protection against the serious consequences of function failure should always be built into the system. For each application an assessment should be made for the consequences of pressure failure and uncontrolled or blocked movements.

To determine the degree of protection that is required to be built into the application, system tools such as an FMEA (Failure Mode and Effect Analysis) and Hazard and Risk Analysis can be used.

#### **FMEA (Failure Mode and Effect Analysis) IEC EN 61508**

FMEA is a tool used for analyzing potential risks. This analytical technique is utilized to define, identify, and prioritize the elimination or reduction of known and/or potential failures from a given system before it is released for production.

Please refer to IEC FMEA Standard 61508.

#### **Hazard and risk analysis ISO 12100-1/14121**

This analysis is a tool used in new applications as it will indicate whether there are special safety considerations to be met according to the machine directives EN 13849.

Dependent on the determined levels conformity this analysis will determine if any extra requirements for the product design, development process, production process or maintenance, i.e. the complete product life cycle.

#### **Warning**

---

All makes/brands and types of directional control valves – inclusive proportional valves – can fail and cause serious damage. It is therefore important to analyze all aspects of the application.

Because the proportional valves are used in many different operation conditions and applications, the manufacturer of the application is alone responsible for making the final selection of the products – and assuring that all performance, safety and warning requirements of the application are met.

The process of choosing the control system – and safety levels – is governed by the machine directives EN 13849 (Safety related requirements for control systems).

---

**Safety**

**Example of a control system for manlift**

*Example of a control system for man-lift*



Example of a control system for man-lift using PVE Fault monitoring input signals and signals from external sensors to ensure the PLUS+1® main controllers correct function of the man-lift.

*Typical PVE wiring block diagram*

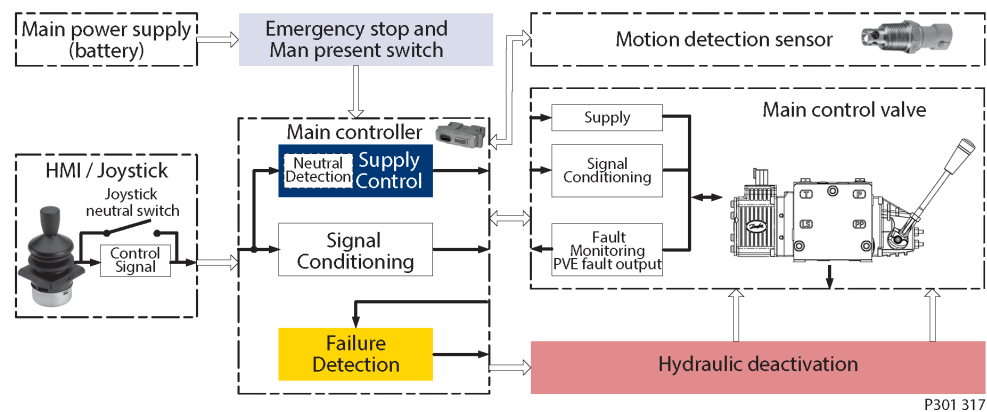

**Warning**

It is the responsibility of the equipment manufacturer that the control system incorporated in the machine is declared as being in conformity with the relevant machine directives.

**Safety**

**PVG 32 – used in system with fixed displacement pumps:**

- PVSK, commonly used in crane application - full flow dump
- PVPX, LS dump to tank

**PVG 100 – alternative LS dump/pilot supply disconnect:**

- PVPP, pilot oil supply shut off
- External cartridge valve connecting LS pressure or main pressure to tank

**PVG 120 – pump disconnect/block for variable pumps:**

- PVPE, full flow dump for the PVG 120
- External cartridge valve connecting LS pressure to tank

**Examples of wiring block diagram**

Example 1

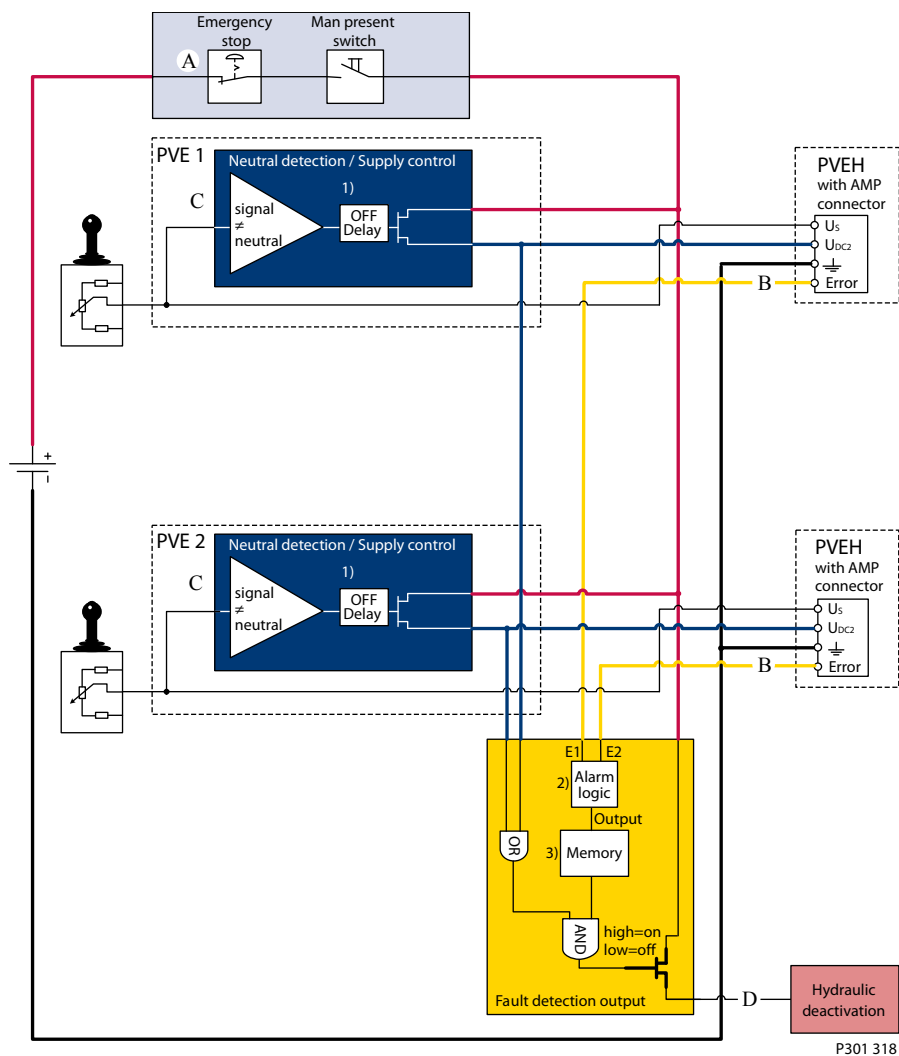

Typical wiring block diagram using PVEH with neutral power off switch and fault monitoring output for hydraulic deactivation.

**Safety**

- A** Emergency stop / man present switch
- B** PVE Fault monitoring signals
- C** Neutral signal detection
- D** Deactivation of the hydraulic system (System Control Logic, example: PLUS+1® for signal monitoring and triggering signal)

**Warning**

It is the responsibility of the equipment manufacturer that the control system incorporated in the machine is declared as being in conformity with the relevant machine directives.

Example 2

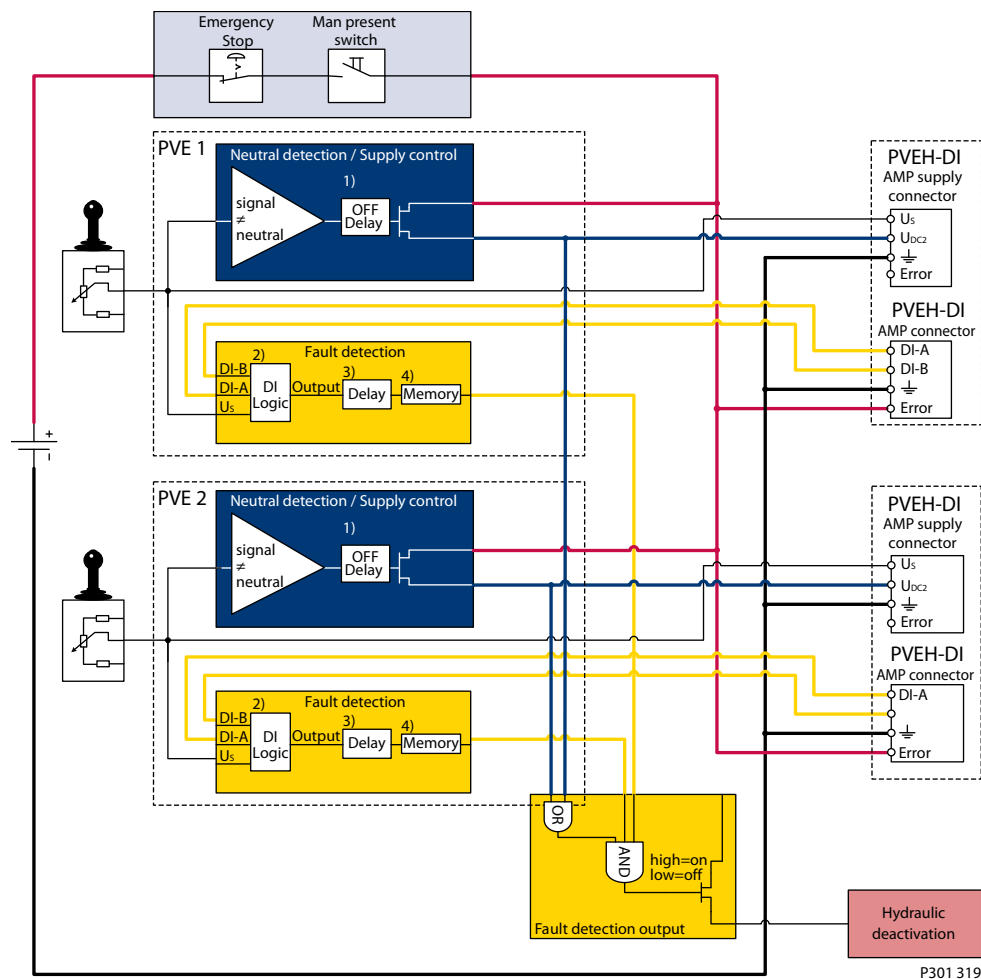

Fault monitoring for deactivation of the hydraulic system with extra fault inputs using the PVE's with DI (Direction Indication) function. System Control Logic, example PLUS+1® for signal monitoring and triggering signal for deactivation of the hydraulic system.

**Warning**

It is the responsibility of the equipment manufacturer that the control system incorporated in the machine is declared as being in conformity with the relevant machine directives.

**Safety**

**Example of fault monitoring**

Similar to previous example using fault monitoring for deactivation of the hydraulic system with extra fault inputs using the PVE's with DI (Direction Indication) function.

*Example of fault monitoring for deactivation of the hydraulic system*

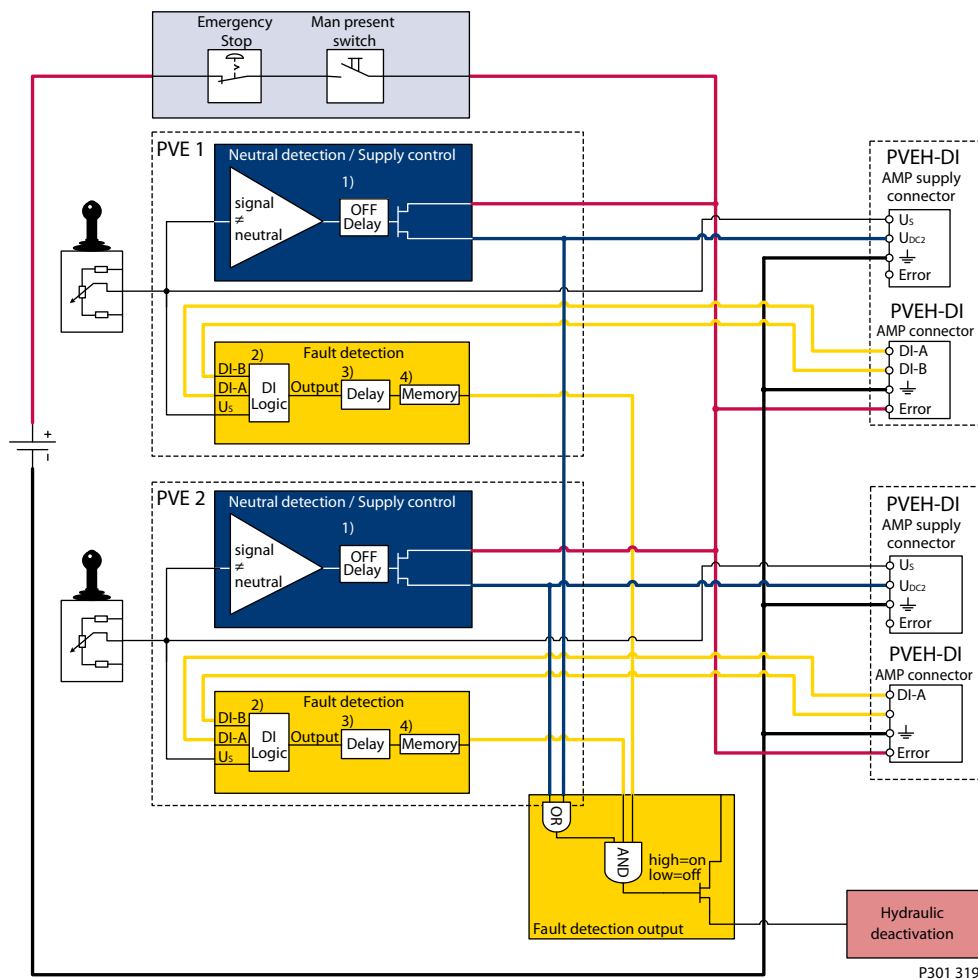

System Control Logic e.g. PLUS+1® for signal monitoring and triggering signal for deactivation of the hydraulic system.

**⚠ Warning**

It is the equipment manufacturers responsibility to ensure that the control system incorporated in the machine is declared as being in conformity with the relevant machine directives.

Other non-electrical modules which can be used in connection with hydraulic deactivation at different levels.

## Safety

### **PVG 32 – Mainly used in system with fixed displacement pumps**

- PVSK, commonly used in crane application - full flow dump
- PVPX, LS dump to tank

### **PVG 100 – Alternative LS dump or pilot supply disconnect**

- PVPP, pilot oil supply shut off
- External cartridge valve connecting LS Pressure to Tank
- External cartridge valve connecting main Pressure to Tank

### **PVG 120 – Pump disconnect/block for variable pumps**

PVPE, full flow dump for the PVG 120



## Technical data

### PVG 100 technical data

The technical data for PVG 100 are typical measured results. For the hydraulic system a mineral based hydraulic oil with a viscosity of 21 mm<sup>2</sup>/s [102 SUS] and a temperature of 50 °C [122 °F] was used.

#### PVG 100 technical data

Max. pressure	Port P continuous	350 bar	[5075 psi]
	Port P intermittent <sup>1)</sup>	400 bar	[5800 psi]
	Port A/B <sup>2)</sup>	350 bar	[5075 psi]
	Port T, static / dynamic	25 bar/40 bar	[365/580 psi]
	Port T0, static / dynamic	5 bar/10 bar	[75/145 psi]
Oil flow, rated (See characteristics)	Port P (PVPV / PVPVM)	250/400 l/min	[66/106 US gal/min]
	Port A/B, with press. comp. @15 bar [217psi] <sup>3)</sup>	180 l/min 240 l/min	[47.6 US gal/min] [63.4 US gal/min]
Spool travel, standard		± 7 mm	[±0.28 in]
Spool travel, float position spool P→A→F	Proportional range	A: 5.5 mm B: 7.0 mm	A: [±0.22 in] B: [±0.28 in]
	Float position	8 mm	[±0.32 in]
Dead band, flow control spools	Standard	± 1.5 mm	[±0.06 in]
Max. spool leakage at 100 bar [1450 psi] and 21 mm <sup>2</sup> /s [102 SUS]	A/B→T, without shock valve <sup>3)</sup>	20/30 cm <sup>3</sup> /min	[1.22/1.85 in <sup>3</sup> /min]
	A/B→T, with shock valve <sup>3)</sup>	25/35 cm <sup>3</sup> /min	[1.53/2.14 in <sup>3</sup> /min]
Max. internal leakage with pilot operated check valve at 200 bar [2900 psi] and 21 mm <sup>2</sup> /s [102 SUS]	A/B→T, without shock valve	1 cm <sup>3</sup> /min	[0.06 in <sup>3</sup> /min]
	A/B→T, with shock valve	6 cm <sup>3</sup> /min	[0.37 in <sup>3</sup> /min]
Oil temperature (inlet temperature)	Recommended temperature	30 → 60°C	[86 → 140°F]
	Min. temperature	-30°C	[-22°F]
	Max. temperature	+90°C	[194°F]
Oil viscosity	Operating range	12 - 75 mm <sup>2</sup> /s	[65 - 347 SUS]
	Min. viscosity	4 mm <sup>2</sup> /s	[39 SUS]
	Max. viscosity	460 mm <sup>2</sup> /s	[2128 SUS]
Ambient temperature		-30 → +60°C	[-22 → +140°F]
Filtration / Max. contamination (ISO 4406)		23/19/16	

<sup>1)</sup> Intermittent operation: the permissible values may occur for max. 10% of every minute.

<sup>2)</sup> PVG 100-HF - 350 bar [5075 psi] rated for 250 000 cycles, max. continuous pressure 320 bar [4640 psi].

<sup>3)</sup> PVG 100-HF - High Flow option work section.

### PVH, hydraulic actuation

#### PVH, Hydraulic Actuation

PVH data	Pressure, bar [psi]
Control range	5 to 15 [75 to 220]
Maximum pilot pressure, static	30 [435]
Maximum pressure on port T (It is recommended that the tank connection from the hydraulic remote control unit PVRH is taken directly to tank.)	10 [145]

**Technical data**

**PVG 100 PVM operating force**

*PVM operating force*

	Actuation	Neutral position	Max. spool travel	
<b>Operating force</b>	PVM + PVMD, PVM + PVE (PVE without voltage applied)	22 ± 3 N [5 ± 0.7 lbf]	28 ± 3 N [6.3 ± 0.7 lbf]	
	PVM + PVH	27 ± 3 N [6 ± 0.7 lbf]	83 ± 3 N [18.7 ± 0.7 lbf]	
	PVM + PVMR	Spool displacement from neutral position	34 N [7.6 lbf]	
		Spool displacement from any other position	12 N [2.7 lbf]	
	PVM + PVMF	Spool displacement from neutral position	22 N [5.0 lbf]	
		Spool displacement into float position	60 N [13.5 lbf]	
Spool displacement away from float position		28 N [6.3 lbf]		
<b>Proportional regulation range, control lever, standard spool</b>		±19.5°		
<b>Proportional regulation range Float position</b>		±15.3° 22.3°		
<b>Control lever positions</b>		No. 2 × 6		

**PVG 100 PVE reaction time and oil consumption**

*PVE reaction time (s)*

Voltage	Reaction time function		PVEO ON/OFF	PVEA <sup>1)</sup> Prop. fine	PVEH Prop. high	PVES Prop. super
<b>Neutral switch</b>	From neutral position to max. spool travel	Max.	0.235	0.500	0.230	0.230
		Rated	0.180	0.320	0.150	0.150
		Min.	0.120	0.250	0.120	0.120
	From maximum spool travel to neutral position	Max.	0.175	0.550	0.175	0.175
		Rated	0.090	0.400	0.090	0.090
		Min.	0.065	0.300	0.065	0.065
<b>Constant voltage</b>	From neutral position to maximum spool travel	Max.	–	0.500	0.200	0.200
		Rated	–	0.320	0.120	0.120
		Min.	–	0.250	0.050	0.050
	From maximum spool travel to neutral position	Max.	–	0.250	0.100	0.100
		Rated	–	0.200	0.090	0.090
		Min.	–	0.150	0.065	0.065
<b>Hysteresis <sup>2)</sup></b>		Rated	-	2%	4%	<1%

<sup>1)</sup> For standard PVG 100 spools.

<sup>2)</sup> Hysteresis is indicated at rated voltage and f = 0.02 Hz for one cycle. A cycle including N > full A > N > full B > N.

*PVE oil consumption, l/min [US gal/min]*

Voltage	Function		PVEO ON/OFF	PVEA <sup>1)</sup> Prop. fine	PVEH Prop. high	PVES Prop. super
<b>Without voltage</b>	Pilot oil flow per PVE	Neutral	0			
<b>With voltage</b>		Locked	0.1 [0.026]	0.5 [0.132]	0.1 [0.026]	0.2 [0.053]
		1 actuation	0.2 [0.053]			
		Actuations	0.7 [0.185]	0.75 [0.2]	1.1 [0.29]	1.1 [0.29]

<sup>1)</sup> For standard PVG 100 spools.

## Technical data

### PVEO power supply and consumption

Supply voltage $U_{DC}$	rated	12 V <sub>DC</sub>	24 V <sub>DC</sub>
	range	11 V to 15 V	22 V to 30 V
	max. ripple	5%	
Current consumption at rated voltage		0.65 A @ 12 V	0.33 A @ 24 V
Input impedance in relation to $0.5 \cdot U_{DC}$		12 K $\Omega$	
Power consumption		8 W	

### PVEA, PVEH and PVES

Supply voltage $U_{DC}$	rated	11 V to 32 V	
	range	11 V to 32 V	
	max. ripple	5%	
Current consumption at rated voltage	PVEH/PVES (PVEA)	0.57 (0.28) A @ 12 V	0.3 (0.15) A @ 24 V
Signal voltage	neutral	$0.5 \cdot U_{DC}$	
	A-port ↔ B-port	$0.25 \cdot U_{DC}$ to $0.75 \cdot U_{DC}$	
Signal current at rated voltage		0.25 mA to 0.70 mA	
Input impedance in relation to $0.5 \cdot U_{DC}$		12 K $\Omega$	
Input capacitor		100 nF	
Power consumption	PVEH/PVES (PVEA)	7 (3.5) W	

For detailed information, see PVE actuator catalog, **520L0553**.

**Technical characteristics**

The characteristics in this catalog are typical measured results. During measuring a mineral based hydraulic oil with a viscosity of 21 mm<sup>2</sup>/s [102 SUS] at a temperature of 50°C [122°F] was used.

**PVPF, pump side module**

*Pressure relief valve characteristic in PVP*

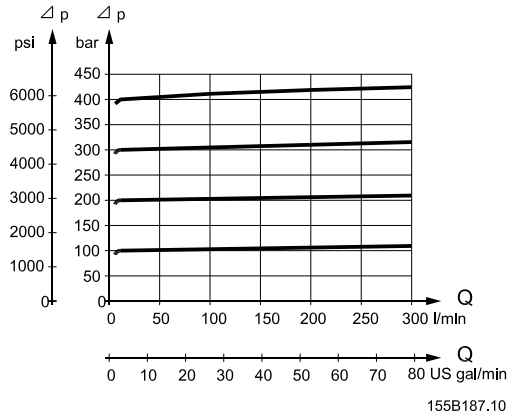

*Neutral flow pressure in PVP, open center*

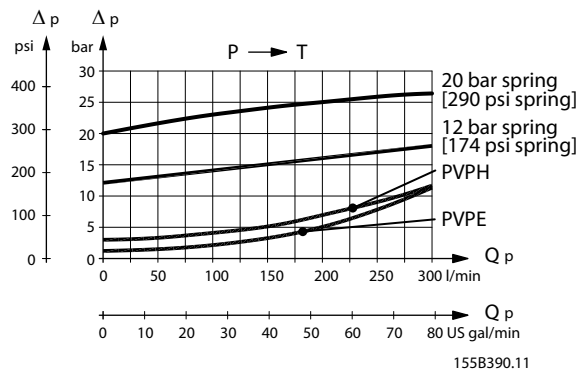

The pressure relief valve is set at an oil flow of 15 l/min [4 US gal/min]. Setting range: 30 to 350 bar [435 to 5075 psi].

**Open center flow rating**

The flow rating of the different main spools will depend on the standby pressure available. In open center systems, the standby pressure equals the pressure drop P→T, see [the diagram above](#). A pump flow of 150 l/min led to tank across the pressure adjusting spool, will generate a standby pressure of app. 15 bar (PVP with 12 bar spring). The according main spool flow ratings will correspond to the curves.

For PVPs with a 20 bar spring, the standby pressure available will be 20 bar or higher. Hence the according main spool flow ratings will correspond.

**Closed center flow rating**

The flow rating of a the different main spools, PVBS, is dependent upon the Load Sense margin (pump margin pressure). The nominal flows specified for each PVBS is specified at 15 bar [218 psi] Ls margin pressure. If LS margin is increased above 15 bar [218 psi], the PVBS will deliver more flow then the nominal rating. The following curves show the relationship between LS margin and work port flow.

### Technical characteristics

#### Flow vs. LS margin @ maximum spool shift

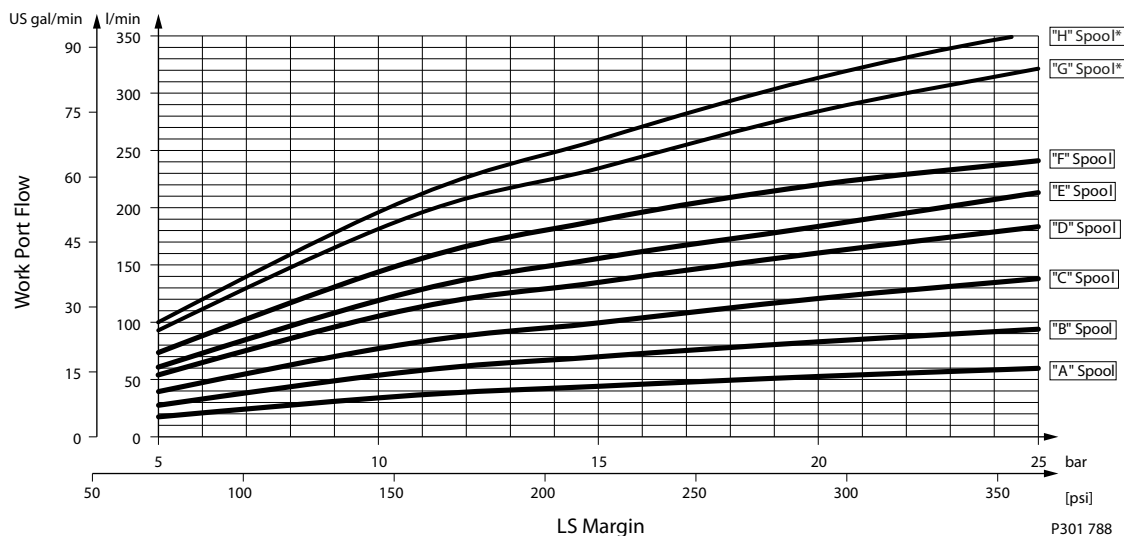

\*With PVG100 High Flow body and spool

**! Caution**

Because of flow forces, cylinder differential areas, Danfoss recommends LS margins under 25 bar [360 psi].

As noted above, work port flow is dependent upon the LS margin set on the pump. PC pumps maintain a constant discharge pressure which is equal to the PC setting on the pump. Hence the LS margin for PC pumps can be thought of as the difference between the PC setting and the load pressure. Therefore work port flow will change with load pressure, thus, pressure compensated flow will not be obtained.

#### PVG 100 pressure drop for PVB, basic module

##### Pressure drop PVB at max. main spool travel

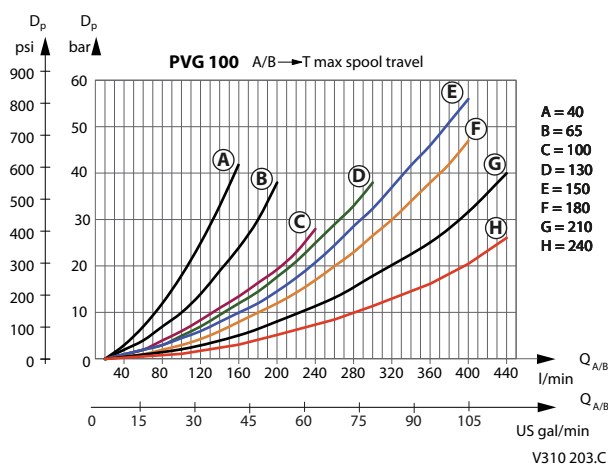

**Technical characteristics**

*Pressure drop PVB for open spool in neutral position*

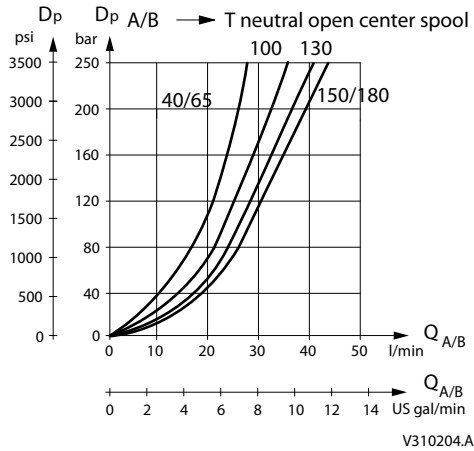

**PVB with pressure compensation, closed center PVP**

*Oil flow as a function of spool travel for spools A to F - 20 bar [290 psi]*

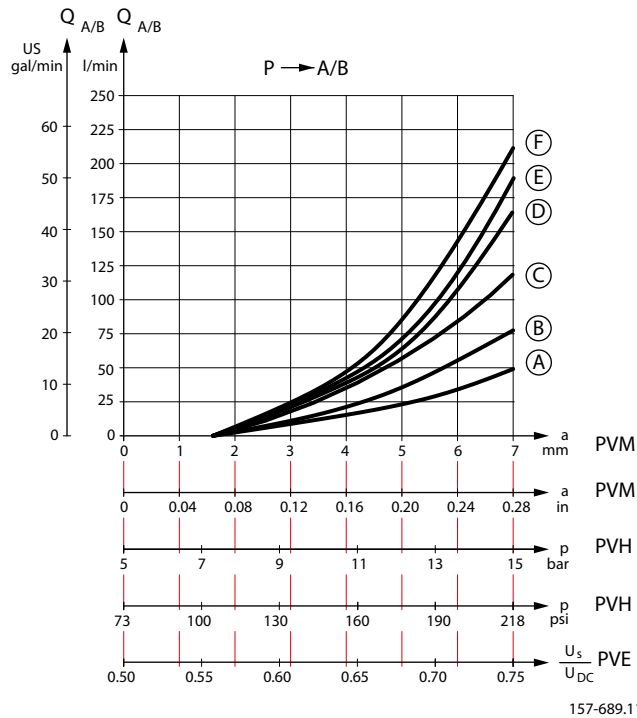

Set pressure difference between pump pressure and LS signal = 20 bar [290 psi] measured at the P-port of the valve.

**Technical characteristics**

*Oil flow as a function of spool travel for spools A to F - 15 bar [218 psi]*

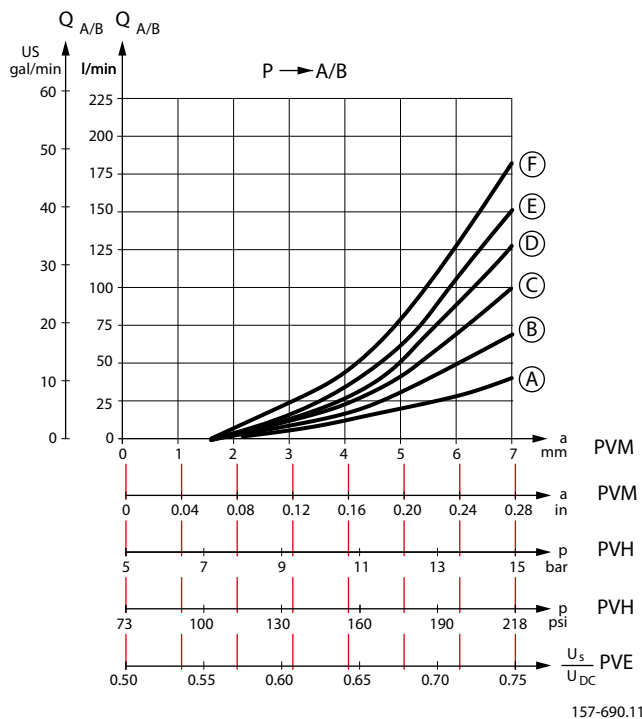

Set pressure difference between pump pressure and LS signal = 15 bar [218 psi] measured at the P-port of the valve.

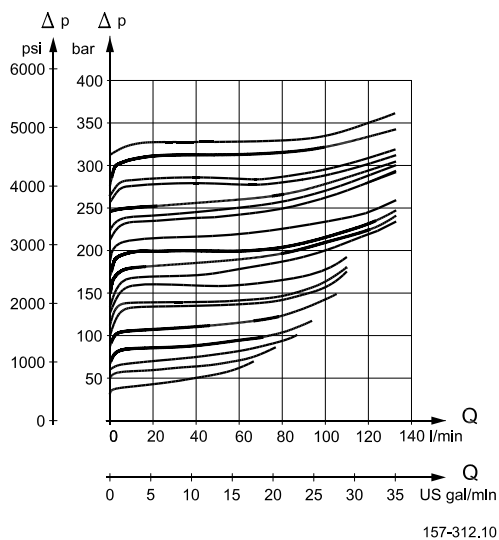

PVLP, shock and suction valve.

**Technical characteristics**

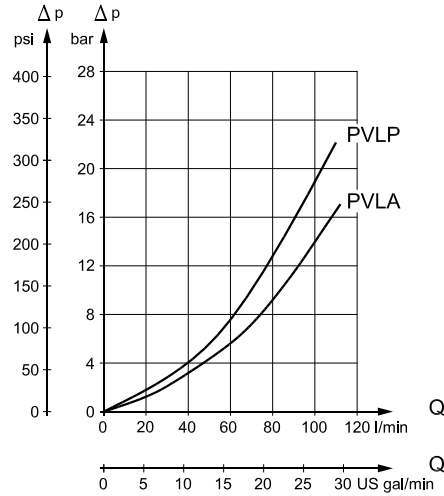

157-313.10

PVLP/PVLA, suction valve.

The shock valve PVLP is designed to absorb shock effects. Consequently, it should not be used as a pressure relief valve. PVLP is set at an oil flow of 10 l/min [2.6 US gal/min].

*Oil flow as a function of spool travel for float spools A-F - 15 bar [218 psi] margin*

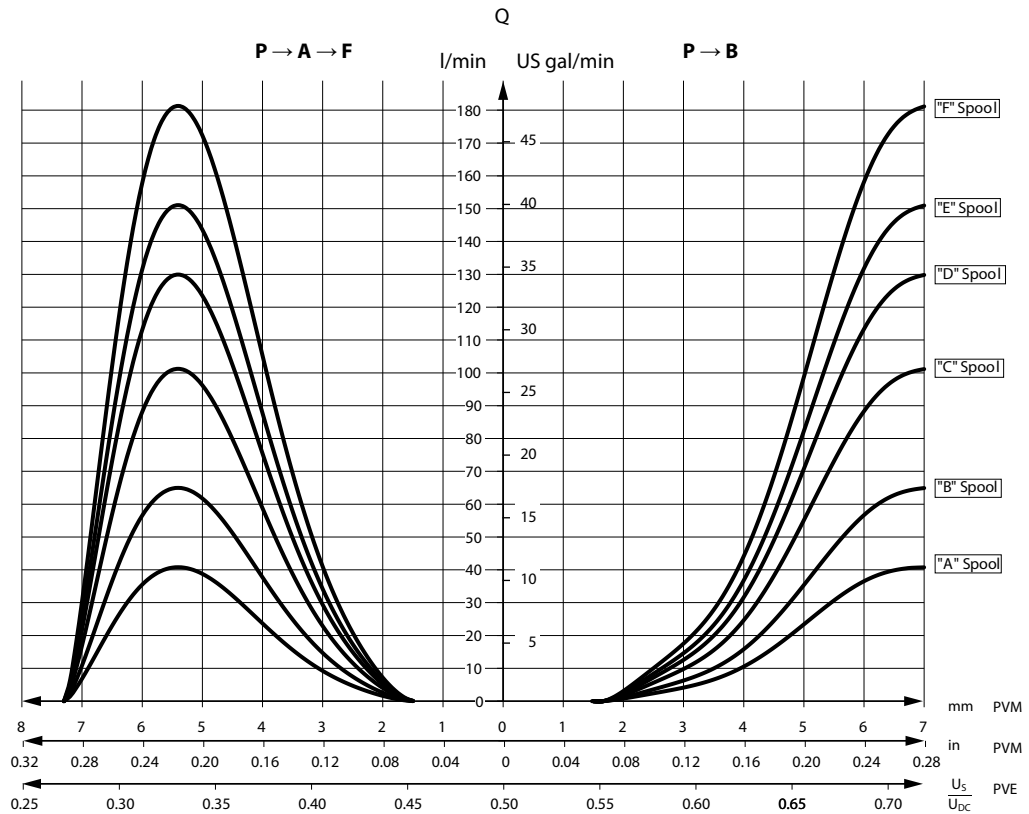

P301 789



### Technical characteristics

#### PVHC characteristic - Spool stroke vs current

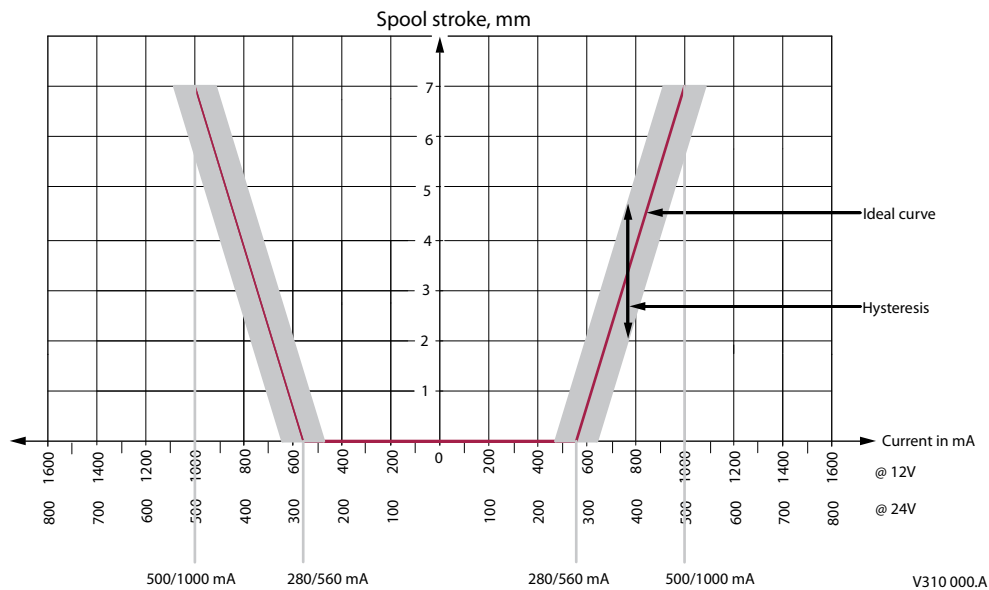

PVHC current response and hysteresis @ 25 bar  $P_p$ , 21 ctS, 25 °C. The ideal curve is determined by the main spool neutral spring. The PVHC has high hysteresis. The hysteresis is affected by viscosity, friction, flow forces, dither frequency and modulation frequency. The spool position will shift when conditions are changed e.g. temperature change.

**Hydraulic systems**

**PVG 100 with variable displacement pump schematic example**

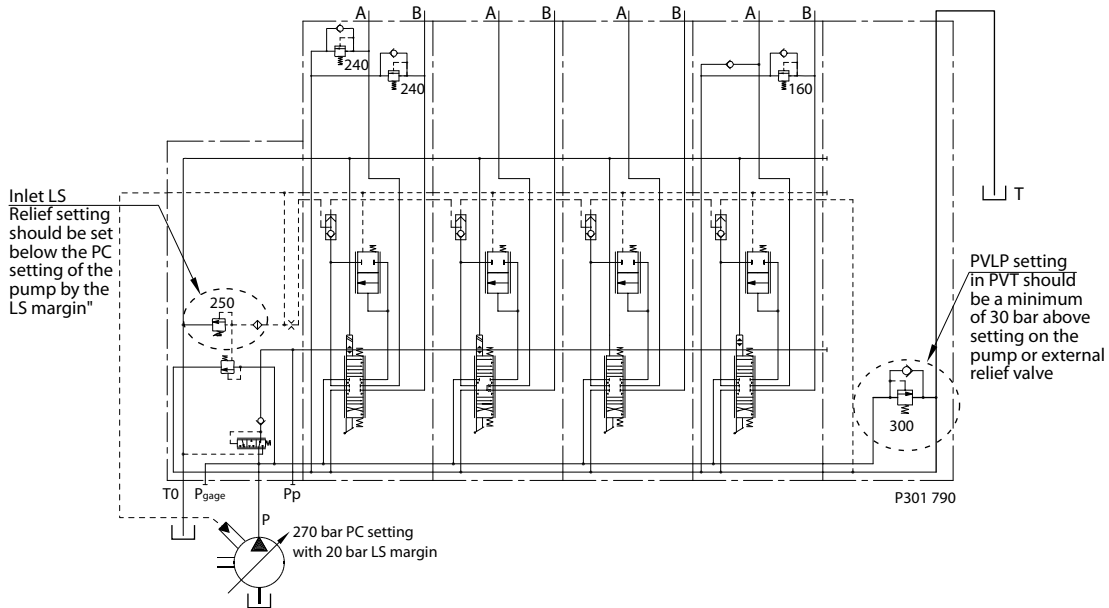

**Electrically actuated PVG 100, variable displacement pump, PVB 100 with integrated pilot operated check valves**

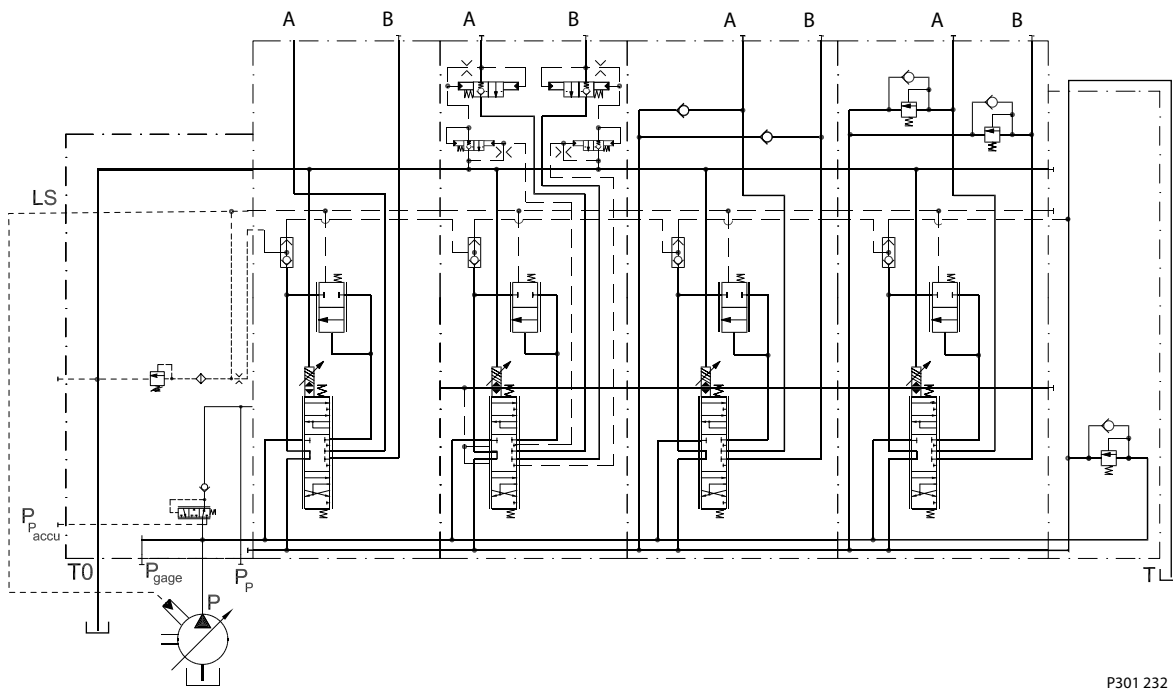

### Hydraulic systems

#### Electrically actuated PVG 100/32, fixed displ. pump, PVB 100/32 with integrated pilot operated check valves

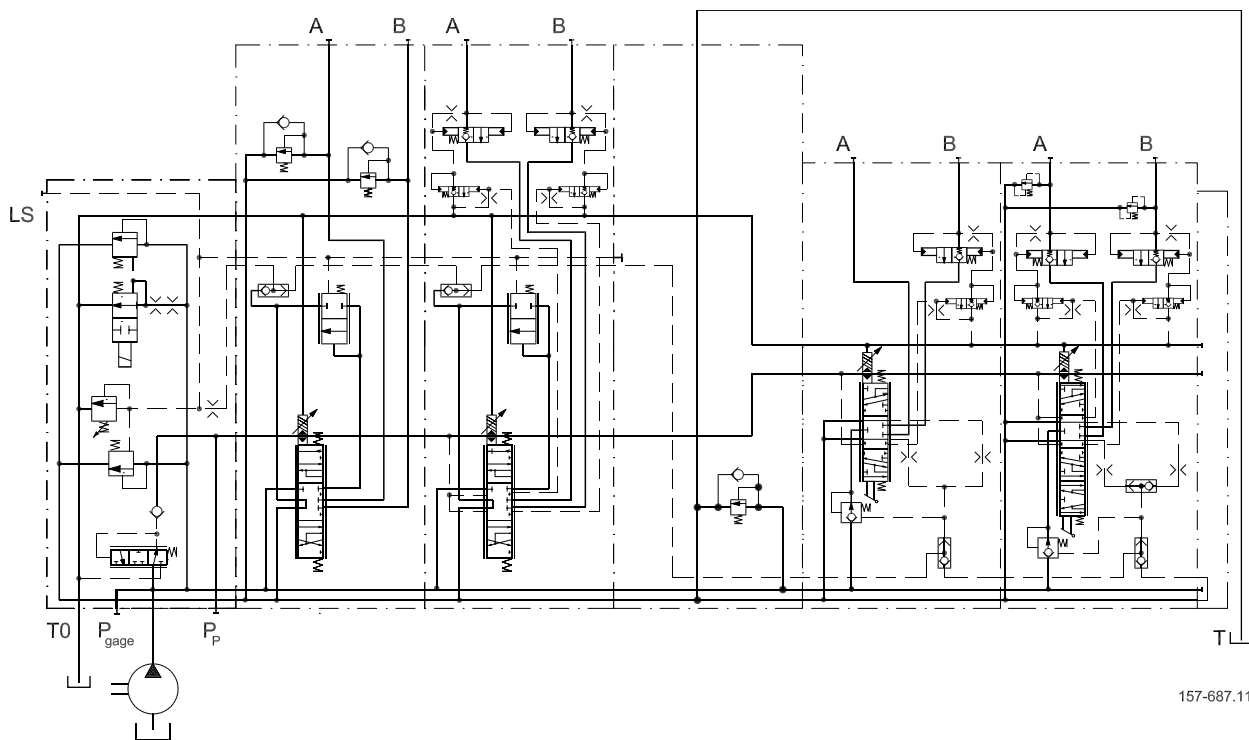

157-687.11

## Other operating conditions

### Oil

The main duty of the oil in a hydraulic system is to transfer energy; but it must also lubricate the moving parts in hydraulic components, protect them against corrosion, and transport dirt particles and heat out of the system. It is therefore important to choose the correct oil with the correct additives. This gives normal operation and long working life.

#### Mineral oil

For systems with this valve Danfoss recommends the use of mineral-based hydraulic oil containing additives: Type HLP (DIN 51524) or HM (ISO 6743/4).

#### Non-flammable fluids

Phosphate-esters (HFDR fluids) can be used without special precautions. However, dynamic seals must be replaced with FPM (Viton) seals. Please contact the Danfoss Sales Organization, if the PVG 100 valve is to be used with phosphate-esters.

The following fluids should only be used according to agreement with the Sales Organization for Danfoss:

- Water-glycol mixtures (HFC fluids)
- Water-oil emulsions (HFB fluids)
- Oil-water emulsions (HFAE fluids)

#### Biodegradable oils

PVG 100 valves can be used in systems with rapeseed oil.

The use of rapeseed oil is conditioned by:

- complying with the demands on viscosity, water content, temperature and filtering etc. (see chapters below and technical data page 7).
- adapting the operating conditions to the directions of the oil supplier.

Before using other biodegradable fluids, please consult the Danfoss Organization.

## Particle Content, Degree of Contamination

Oil filtration must prevent the particle content from exceeding an acceptable level, i.e. an acceptable degree of contamination.

Maximum contamination for is 23/19/16 (see ISO 4406).

Calibration in accordance with the ACFTD method.

A degree of contamination of 23/19/16 can be maintained by using a filter fineness as described in the next section.

## Filtration

Effective filtration is the most important precondition in ensuring that a hydraulic system performs reliably and has a long working life. Filter manufacturers issue instructions and recommendations. It is advisable to follow these.

#### System filters

Where demands on safety and reliability are very high a pressure filter with bypass and indicator is recommended. Experience shows that a 10 µm nominal filter (or finer) or a 20 µm absolute filter (or finer) is suitable. It is our experience that a return filter is adequate in a purely mechanically operated valve system. The fineness of a pressure filter must be selected as described by the filter manufacturer so that a particle level of 23/19/16 is not exceeded. The filter must be fitted with pressure gauge or dirt indicator to make it possible to check the condition of the filter. In systems with differential cylinders or accumulators

### **Other operating conditions**

the return filter must be sized to suit the max. return oil flow. Pressure filters must be fitted to suit max. pump oil flow.

#### **Internal filters**

The filters built into PVG 32 are not intended to filter the system but to protect important components against large particles. Such particles can appear in the system as a result of pump damage, hose fracture, use of quick-couplings, filter damage, starting up, contamination, etc. The filter in the electrical actuator PVE protecting the solenoid valves has a mesh of 150 µm. Bursting pressure drop for internal filters is 25 bar [360 psi].

## Mounting

### Standard mounting vs. option mounting

*Standard mounting – the PVM on the “A” port side of the PVB*

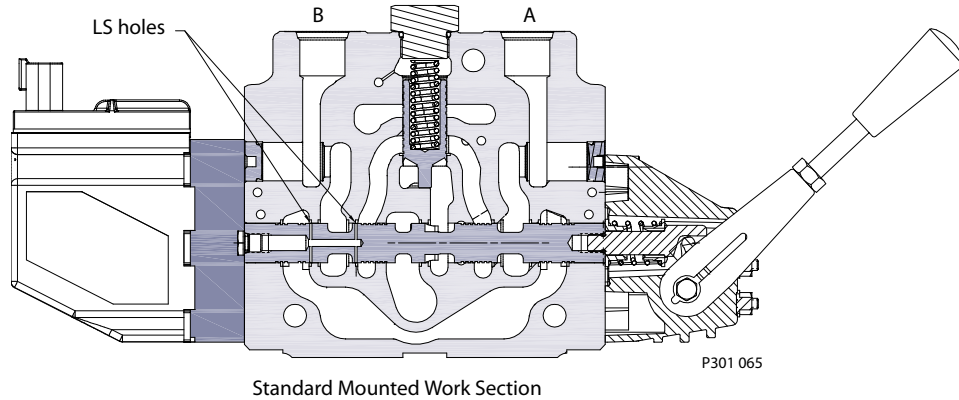

Standard mounting is defined as installing the PVM on the “A” port side of the PVB. Because of this, the PVE or PV cover (PVH, PVMD, PVMR, PVMF or PVHC) would be on the “B” port side of the valve.

*Option mounting – the PVM on the “B” port side of the PVB*

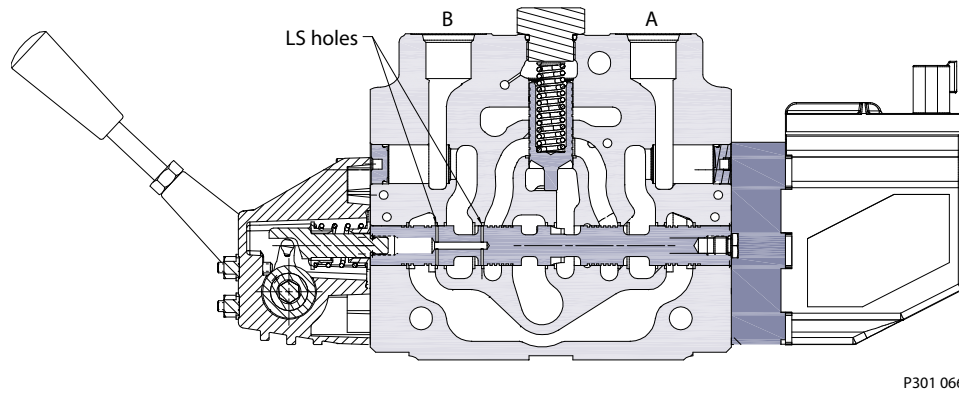

Option mounting is defined as installing the PVM on the “B” port side of the PVB. Because of this, the PVE or PV cover (PVH, PVMD, PVMR, PVMF or PVHC) would be on the “A” port side of the valve.

The PVBS in PVG 100 are not symmetric. Because of this the “Load Sense” (Ls) holes in the PVBS main spool must be installed so that they are on the “B” port side of the PVB.

*Standard mounting spool (upper PVBS) vs. Option mounting spool (below PVBS)*

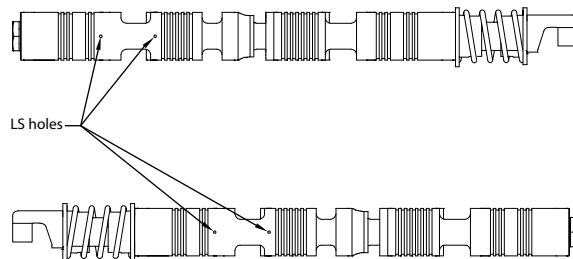

Before determining spool part numbers, determine whether the section will be standard or option mounted. Standard and Option mounting only applies to a work section. Standard and option mounted section can be used together in the same stack.

## Modules and code numbers

### PVPF (Open Center) Inlet Modules - for Pumps with Fixed Displacement

Symbol	Description	BSP port G1	SAE Port 1.5/16-12
<p>P301 051</p>	Open center pump side module for pumps with fixed displacement. Max pump flow 250 l/min [66 US gal/min]. With pilot supply for PVE actuation. With pilot gauge port.	12 bar spring*	161B5110
		20 bar spring*	161B5112
	Open center pump side module for pumps with fixed displacement. Max pump flow 250 l/min [66 US gal/min]. With pilot supply for PVH/PVHC actuation. With pilot gauge port.	12 bar spring*	11013065
		20 bar spring*	11013067
<p>P301 052</p>	Open center pump side module for pumps with fixed displacement. Max pump flow 250 l/min [66 US gal/min]. With pilot supply for PVE actuation. Accumulator port and facility for pilot shut-off valve (PVPP).	12 bar spring*	161B5140
		20 bar spring*	161B5142
	Open center pump side module for pumps with fixed displacement. Max pump flow 250 l/min [66 US gal/min]. With pilot supply for PVH/PVHC actuation. Accumulator port and facility for pilot shut-off valve (PVPP).	12 bar spring*	11013071
		20 bar spring*	11013073
		* Spring for pressure matching spool - PVPF only.	

\* PVPD (dummy spool)/PVPE/PVPH should be specified with any PVPF module. \*\*PVPE/PVPH will electrically or hydraulically unload pump flow to tank for a low pressure standby (refer to [Technical characteristics](#) on page 28).

### PVPF Accessories for Pump Side Modules

Symbol	Description	Code Number
—	Dummy Spool	155G5041
<p>P301 053</p>	PVPE Electrically actuated normally open, unloading valve If PVPE or PVPH is not required the "Dummy Spool" must be specified	12 V 155G5052 24 V 155G5054
	<p>P301 797</p>	PVPH Hydraulically actuated unloading valve If PVPE or PVPH is not required the "Dummy Spool" must be specified.

\* Connection for external pilot pressure: available with G1/4 thread only. Pilot source should be independent of LS pressure (LS pressure may not be enough to pilot PVPH).

**Modules and code numbers**

**PVP (Open and Closed) Accessories for Pump Side Modules**

Symbol	Description	Code Number
	<b>PVPP</b> Electrically Actuated Pilot Shut Off Valve Normal Closed Solenoid Valve	12 V 11160318
		24 V 11160319

**PVPV (Closed Center) Inlet Modules**

Symbol	Description	BSP port G1	SAE Port 1 5/16-12
	Closed Center Pump Side Module for pumps with variable displacement. Max pump flow 250 l/min [66 US gal/min]. With pilot supply for PVE actuation. With pilot gauge port.	161B5111	161B5511
	Closed Center Pump Side Module for pumps with variable displacement. Max pump flow 250 l/min [66 US gal/min]. With pilot supply for PVH/PVHC actuation. With pilot gauge port.	11013069	11013070
	Closed Center Pump Side Module for pumps with variable displacement. Max pump flow 250 l/min [66 US gal/min]. With pilot supply for PVE actuation. With pilot gauge port. Accumulator port and facility for pilot shut off valve.	161B5141	161B5541
	Closed Center Pump Side Module for pumps with variable displacement. Max pump flow 250 l/min [66 US gal/min]. With pilot supply for PVH/PVHC actuation. With pilot gauge port. Accumulator port and facility for pilot shut off valve.	11013075	11013076



**Modules and code numbers**

**PVPVP, Closed Center Priority Side Modules - for Pumps with Variable Displacement**

Symbol	Description	Code Number	
		BSP port P: G $\frac{3}{4}$ T: G1 CF: G $\frac{1}{2}$	SAE port P: 1 1/16-12 T: 1 5/16-12 CF: 3/4-16
	<p>PVPVP            Closed Center Pump Side Modules for pumps with variable displacement            Max pump flow 250 l/min [66 US gal/min]            Max CF flow 60 l/min [15.9 US gal/min]            With integrated priority function            With pilot supply for PVE actuation</p>	161B5211	161B5611
	<p>PVPVP            Closed Center Pump Side Modules for pumps with variable displacement            Max pump flow 250 l/min [66 US gal/min]            Max CF flow 60 l/min [15.9 US gal/min]            With integrated priority function            With pilot supply for PVH/PVHC actuation</p>	11013077	11013078

**PVPVM, Closed Center Mid Inlet Modules - for Pumps with Variable Displacement**

Symbol	Description	Code Number	
		BSP port: P = 1 1/4 Code 62 Metric flange LS, TO, Pg, Pp = G 1/4	SAE port: P = 1 1/4 Code 62 Metric flange LS, TO, Pg, Pp = 9/16-18 UNF
	<p>PVPVM            Mid modules for pumps with variable displ.            Max. pump flow 400 l/min [106 US gal/min]            With pilot supply for PVE actuation</p>	11130086*	11133048*
	<p>PVPVM            Mid modules for pumps with variable displ.            Max. pump flow 400 l/min [106 US gal/min]            With pilot supply for PVH / PVHC actuation</p>	11133046*	11133047

\* Requires two PVAS kits. Mid-inlets require option-mounted spools on one side to keep all PVM or PVE actuators on the same side (PVPVM has milled surfaces on each side).

**Modules and code numbers**

**PVB 100 Basic Modules (Standard Spools)**

*PVB 100 for use with standard spools*

Symbol	Description	PVL P	Code Number	
			BSP port G 3/4	SAE port 1 1/16-12 UNF
	PVB Post compensated	Without	161B6250	161B6650
	PVB end module <sup>1)</sup> Post compensated	Without	—	11036948
		With	11006889	11070866
	PVB with tank port at the bottom Post compensated	With	11006887	—
			<u>To be used with PVB end modules</u>	
	PVBZ Post compensated	Without	161B6252	161B6652
	With pilot operated check valve on work, port A and B	With	161B6262	161B6662
			<u>Not compatible with PVMR or PVMF Spools</u>	

<sup>1)</sup> If mounting is required, use bracket **11144936**, need to have maximum pressure reduced.

**PVB 100 Basic Modules (Exposed spools)**

*PVB 100 for use with exposed spools, seal plate on "A" port side included*

Symbol	Description	PVL P	Code Number	
			BSP port G 3/4	SAE port 1 1/16-12 UNF
	PVB Post compensated	Without	11051707	11051708
		With	11051709	11051710
	PVBZ Post compensated	Without	11051711	11051712
	With pilot operated check valve on work, port A and B	With	11051713	11051714
			<u>Not compatible with PVMR or PVMF Spools</u>	

### Modules and code numbers

#### PVB 100 Basic Modules (High Flow Spools)

*PVB 100 for use with High Flow Spools*

Symbol	Description	Code Number	
		BSP port G 3/4	SAE port 1 3/16-12 UNF
<p>Shown with PVLP Facility            PVLP not included with PVB</p>	PVB Without facility for shock valve	11102180	11102181
	PVB With facility for PVLP (2x for A and B)	11102178	11101825
<p>Shown without PVLP Facility            P301 126</p>	PVB with PVBZ on A and B Without facility for PVLP	11102184	11102185
	PVB with PVBZ on A and B With facility for PVLP (2x for A and B)	11102182	11102183

#### PVG 100 PVM code numbers

Symbol	Description	Code Number	
		with stop screws*	without stop screws
<p>157-10.10</p>	PVM, aluminum housing Standard, spring centered with base/lever kit (22.5°)	157B3171	157B3191
	PVM, aluminum housing Standard, spring centered with base/lever kit (37.5°)	157B3172	157B3192
	PVM, aluminum housing Without actuation lever and base Shaft for mounting of actuation lever	157B3173	157B3193
	PVM, aluminum housing Without actuation lever (37.5°)	157B3174	157B3194
	PVM, aluminum housing With base kit (22.5°)	157B3175	157B3195
	PVM, cast Iron housing Standard, spring centered	157B3161	-
	PVM, anodized aluminum housing Standard, spring centered	157B3184	-

\* Stop screws provide Individual flow adjustment on ports A and B.

#### PVM / PVH, Covers

Symbol	Description	Code Number	
—	PVMD*, Cover for purely mechanical actuation	aluminum	157B0001
		cast iron	157B0021
<p>157-199.11</p>	PVH, Cover for hydraulic remote control	G 1/4	157B0008
		916-18 UNF	157B0007

**Modules and code numbers**

Symbol	Description	Code Number
<p>157-210.10</p>	PVMR*, Cover for friction detent	157B0015
<p>157-208.10</p>	PVMF*, Mechanical float position lock, P -> A -> F	157B0005

\* Opposite of PVM, not compatible with PVG 100 PVBZ.

**PVEO, ON/OFF Actuation**

Symbol	Description	Hirschmann		AMP		Deutsch*		
		12 V	24 V	12 V	24 V	12 V	24 V	
<p>157-36.10</p>	PVEO	ON/OFF	157B4216	157B4228	157B4901	157B4902	157B4291	157B4292
		ON/OFF with ramp	157B4217	157B4229	157B4903	157B4904	11109080	11109092
		ON/OFF anodized	157B4266	157B4268	-	157B4272	-	-

[Refer to catalog 520L0553 for more PVE information.](#)

**PVHC - main spool control**

Symbol	Description	AMP		Deutsch	
		12 V	24 V	12 V	24 V
	<p>PVHC</p> <p>The PVHC is an electrical actuator module for main spool control in PVG 32 and PVG 100. The actuator uses two current controlled proportional pressure reducing valves.</p>	11112037	11112036	11112038	11112039

**PVEA/PVEH/PVES, Proportional Actuation**

Symbol	Description	Hirschmann	AMP	Deutsch*	
		11 - 32 V	11 - 32 V	11 - 32 V	
<p>157-655.10</p>	PVEA*	Standard, active fault monitoring	-	157B4734	157B4792
		Standard, passive fault monitoring	-	157B4735	11107365
	PVEA-DI*	Standard, active fault monitoring	-	157B4736	157B4796
		Standard, passive fault monitoring	-	157B4737	-
<p>157-34.10</p>	PVEH	Standard, active fault monitoring	157B4032	157B4034	157B4092
		Standard, passive fault monitoring	157B4033	157B4035	157B4093
		Standard, passive, anodized	157B4073	-	-
	PVEH-F	Float, passive fault monitoring	-	157B4075	157B4392
		Float, active fault monitoring	157B4332	-	-

**Modules and code numbers**

Symbol	Description	Hirschmann	AMP	Deutsch*	
		11 - 32 V	11 - 32 V	11 - 32 V	
 157-190.10	PVEH-DI				
	Standard, active fault monitoring	-	157B4036	157B4096	
 157-34.10	PVES				
	0% hysteresis, active fault monitoring	157B4832	157B4834	157B4892	
	0% hysteresis, passive fault monitoring	157B4833	157B4835	11089276	
	PVEP	PVEP, voltage PWM, active fault monitoring	-	-	11034832
	PVED	CAN bus interface	-	11079034	11079033

\* PVEA with flows over 130 l/min [34.3 US gal/min] may not shift spool to full stroke

[Refer to catalog 520L0553 for more PVE information.](#)

**PVLA, Anti-Cavitation Valve Fitted into PVB**

Symbol	Description	Code number
	PVLA Anti-cavitation valve installed in PVLP cavity of PVB	157B2001
	Cap For connecting non-active work port to tank	157B2002

**Modules and code numbers**

**PVLP, Shock / Anti-Cavitation Valve Fitted into PVB**

Symbol	Description	Setting		Code number
		bar	psi	
<p>P301 133</p>	PVLP Shock and anti-cavitation valve (Not adjustable)	32	460	157B2032
		50	725	157B2050
		63	914	157B2063
		80	1160	157B2080
		100	1450	157B2100
		125	1813	157B2125
		140	2031	157B2140
		150	2175	157B2150
		160	2320	157B2160
		175	2538	157B2175
		190	2755	157B2190
		210	3045	157B2210
		230	3335	157B2230
		240	3480	157B2240
		250	3625	157B2250
		265	3843	157B2265
		280	4061	157B2280
		300	4351	157B2300
320	4641	157B2320		
350	5075	157B2350		

**PVT 100, Tank Module**

Symbol	Description	Port size	Code number
<p>157-694.11</p>	PVT Without active elements With T-port PVLP shock valve facility	G 1¼	161B2500
		15/8-UNF	161B2520
<p>157-695.11</p>	PVT Without active elements With T-port PVLP shock valve facility With LX connection G1/4 [ 9/16 in – 18 UNF]	G 1¼	161B2505
		15/8-UNF	161B2525

## Modules and code numbers

### PVTI 100/32, Interface Module\*

Symbol	Description	Port size	Code number
	PVTI Without active elements With T-port PVLV shock valve facility	G 1¼	161B2200
		15/8-UNF	161B2220

\* Must use T0 equipped PVG32 Modules, for details see Danfoss Technical Information Basis Modules PVBZ, 520L0721.

### PVG 100 PVSI / PVT, Assembly Kit

Description	Code number 161B....							
	1 PVB	2 PVB	3 PVB	4 PVB	5 PVB	6 PVB	7 PVB	8 PVB
Tie bolts and seals	8001	8002	8003	8004	8005	8006	8007	8008

### PVBE (End Bodies), Assembly Kit

Description	Code number							
	1 PVB	2 PVB	3 PVB	4 PVB	5 PVB	6 PVB	7 PVB	8 PVB
Tie bolts and seals	11081671	11017005	11017006	11017007	11017008	11017009	11017010	11017011

### PVG 100 / PVTI, Interface Module Assembly Kit

Description	Code number								
	0 PVB	1 PVB	2 PVB	3 PVB	4 PVB	5 PVB	6 PVB	7 PVB	8 PVB
Tie bolts and seals	11143008	161B8021	161B8022	161B8023	161B8024	161B8025	161B8026	161B8027	161B8028

### PVB 32, Assembly Kit

Description	Code number 157B....									
	1 PVB	2 PVB	3 PVB	4 PVB	5 PVB	6 PVB	7 PVB	8 PVB	9 PVB	10 PVB
Tie bolts and seals	8000	8001	8002	8003	8004	8005	8006	8007	8008	8009

**Modules and code numbers**

**PVG 32 Basic Modules with T0, PVBZ (Compatible with PVG 100)**

Symbol	Description PVBZ	Without thermal relief valve 157B...		With thermal relief valve 157B...	
		BSP	SAE	BSP	SAE
<p>T P LS P<sub>p</sub> T0 157-587.11</p>	<p>Without compensator and load drop check valve            With pilot operated check valves on work port B            Max. work port pressure = 210 bar [3045 psi]</p>	6051	6451	-	-
<p>T P LS P<sub>p</sub> T0 157-586.13</p>	<p>Without compensator and load drop check valve            With pilot operated check valves on work port A and B            Max. work port pressure = 210 bar [3045 psi]</p>	6052	6452	-	-
<p>T P LS P<sub>p</sub> T0 157-590.11</p>	<p>With compensator            With pilot operated check valves on work port B            Compensated work port flow A/B = 100 l/min [26.4 US gal/min]            Max. work port pressure = 210 bar [3045 psi]</p>	6251	-	6261	6661
<p>T P LS P<sub>p</sub> T0 157-589.11</p>	<p>With compensator            With pilot operated check valves on work port A and B            Compensated work port flow A/B = 100 l/min [26.4 US gal/min]            Max. work port pressure 210 bar [3045 psi]</p>	6252	6652	6262	6662
<p>T P LS P<sub>p</sub> T0 157-588.11</p>	<p>With compensator            With pilot operated check valves on work port A and B            LSA/B shuttle valve for float and shuttle pin            Compensated work port flow A/B = 100 l/min [26.4 US gal/min]            Max. work port pressure 210 bar [3045 psi]</p>	-	-	6266	6666



**Modules and code numbers**

Connection: A and B-port G 1/2 [ 7/8 in - 14]

Please refer to Publications 520L0344 for PVBZ spool selection and to 520L0721 for the PVBZ modules with P.O. check.

**PVG 32 Basic Modules with T0, PVB (Compatible with PVG 100)**

Symbol	Description PVB	Code number 157B.....			
		Without PVL 63		With PVL 63	
		BSP	SAE	BSP	SAE
<p>157-591.11</p>	Without load drop check valve and pressure compensator. Can be used where load holding valves prevent oil from flowing back through the channel P.	6010	6410	-	-
<p>157-592.11</p>	Load drop check valve	6110	6909	6140	6904
<p>157-593.11</p>	With compensator valve	6210	6922	6240	6906
<p>157-594.10</p>	With compensator valve Adjustable LS A/B limiting valves. External LS connection port A/B. Also used for float position spools.	6213	6613	6243	6643

Connection: A and B-port G 1/2 [ 7/8 in - 14]

Refer to Publication **520L0344** for PVB spool selection.

**Modules and code numbers**

**Standard Spools for Electrical and Mechanical Actuation Progressive Flow Characteristics**

Symbol		Pressure Compensated Flow (Specified flow is at 15 bar pump margin pressure) l/min [US gal/min]					
		A 40 [10.6]	B 65 [17.2]	C 100 [26.4]	D 130 [34.4]	E 150 [39.6]	F 180 [47.6]
4-way, 3 position, Closed Neutral Position		161B7022	161B7023	161B7024	161B7025	161B7026	161B7027
Standard Mount							
Option Mount		11013079	11013080	11013081	11013082	11013083	11013084
4-way, 3-position, Throttled Open Neutral Position		161B7122	161B7123	161B7124	161B7125	161B7126	161B7127
Standard Mount							
Option Mount		11013085	11013086	11013087	11013088	11013089	11013090
4-way, 4-position, Closed Neutral Position, Electric float P → A → F		161B7622	161B7623	161B7624	161B7625	161B7626	161B7627
Standard Mount							
Option Mount		11013091	11013092	11013093	11013094	11013095	11013096
4-way, 4-position, Throttled Open Neutral Position Electric Float P → A → F		11016865	11016866	11016867	11016868	11016869	11016870
Standard Mount							
Option Mount		11016871	11016872	11016873	11016874	11016875	11016876

**Standard Spools for Hydraulic Actuation Progressive Flow Characteristics**

Symbol		Pressure compensated Flow (Specified flow is at 15 bar pump margin pressure) l/min [US gal/min]					
		A 40 [10.6]	B 65 [17.2]	C 100 [26.4]	D 130 [34.4]	E 150 [39.6]	F 180 [47.6]
4-way, 3 position, Closed Neutral Position		161B9522	161B9523	161B9524	161B9525	161B9526	161B9527
Standard Mount							
Option Mount		11013097	11013098	11013099	11013100	11013101	11013102
4-way, 3-position, Throttled Open Neutral Position		161B9622	161B9623	161B9624	161B9625	161B9626	161B9627
Standard Mount							
Option Mount		11013103	11013104	11013105	11013106	11013107	11013108

### Modules and code numbers

Symbol		Pressure compensated Flow (Specified flow is at 15 bar pump margin pressure) l/min [US gal/min]					
		A 40 [10.6]	B 65 [17.2]	C 100 [26.4]	D 130 [34.4]	E 150 [39.6]	F 180 [47.6]
4-way, 4-position, Closed Neutral Position, Hydraulic Float P -> A -> F		11134629	11134630	11134631	11134632	11134633	11134634
Standard Mount							
Option Mount		11134635	11134636	11134637	11134638	11134639	11134692

### Spools for Friction Detent, PVMR (not compatible with PVBZ 100) Progressive Flow Characteristics

Symbol		Pressure Compensated Flow (Specified flow is at 15 bar pump margin pressure) l/min [US gal/min]					
		A 40 [10.6]	B 65 [17.2]	C 100 [26.4]	D 130 [34.4]	E 150 [39.6]	F 180 [47.6]
4-way, 3-position, Throttled Open Neutral Position		161B9732	161B9733	161B9734	161B9735	161B9736	161B9737
Standard Mount							
Option Mount		11013109	11013110	11013111	11013112	11013113	11013114

### Spools for Mechanical Float position, PVMF (not compatible with PVBZ 100) Progressive Flow Characteristics

Symbol		Pressure Compensated Flow (Specified flow is at 15 bar pump margin pressure) l/min [US gal/min]					
		A 40 [10.6]	B 65 [17.2]	C 100 [26.4]	D 130 [34.4]	E 150 [39.6]	F 180 [47.6]
4-way, 4 position, Closed Neutral Position		161B9822	161B9823	161B9824	161B9825	161B9826	161B9827
Standard Mount							
Option Mount		11013115	11013116	11013117	11013118	11013119	11013120

### Standard Spools (Electrical and Mechanical Actuation) Linear Flow Characteristics

Symbol		Pressure Compensated Flow (Specified flow is at 15 bar pump margin pressure) l/min [US gal/min]					
		A 40 [10.6]	B 65 [17.2]	C 100 [26.4]	D 130 [34.4]	E 150 [39.6]	F 180 [47.6]
4-way, 3 position, Closed Neutral Position		11016852	11016853	11016854	11016855	11016857	11016858
Standard Mount							
Option Mount		11016859	11016860	11016861	11016862	11016863	11016864

**Modules and code numbers**

**Standard Spools (Electrical and Mechanical Actuation) Throttled Open in Neutral, Linear Flow Characteristics**

Symbol		Pressure Compensated Flow (Specified flow is at 15 bar pump margin pressure) l/min [US gal/min]					
		A 40 [10.6]	B 65 [17.2]	C 100 [26.4]	D 130 [34.4]	E 150 [39.6]	F 180 [47.6]
4-way, 3-position, Throttled Open Neutral Position		11116606	11116607	11116608	11116609	11116610	11116611
Standard Mount							
Option Mount		-	-	11090529	11090653	-	-

**Standard Spools (Hydraulic and Mechanical Actuation), Throttled Open in Neutral, Linear Flow Characteristics**

Symbol		Pressure Compensated Flow (Specified flow is at 15 bar pump margin pressure) l/min [US gal/min]					
		A 40 [10.6]	B 65 [17.2]	C 100 [26.4]	D 130 [34.4]	E 150 [39.6]	F 180 [47.6]
4-way, 3 position, Throttled Open, Neutral Position		11116612	11116613	11116614	11116615	11116616	11116617
Standard Mount							

**Standard Spools (Electrical and Mechanical Actuation), Full Open in Neutral; Progressive Flow Characteristics**

Symbol		Pressure Compensated Flow (Specified flow is at 15 bar pump margin pressure) l/min [US gal/min]					
		A 40 [10.6]	B 65 [17.2]	C 100 [26.4]	D 130 [34.4]	E 150 [39.6]	F 180 [47.6]
4-way, 3 position, Full Open, Neutral Position		11121597	11121598	11121599	11121600	11121601	11145837
Standard Mount							

**Standard Spools (Hydraulic and Mechanical Actuation), Full Open in neutral; Linear Flow Characteristics**

Symbol		Pressure Compensated Flow (Specified flow is at 15 bar pump margin pressure) l/min [US gal/min]					
		A 40 [10.6]	B 65 [17.2]	C 100 [26.4]	D 130 [34.4]	E 150 [39.6]	F 180 [47.6]
4-way, 3 position, Full Open, Neutral Position		11121602	11121603	11121604	11121605	11121606	11005747
Standard Mount							

## Modules and code numbers

### High Flow Spools (Electrical and Mechanical Actuation) Progressive Flow Characteristics

*High Flow Spools (Electrical and Mechanical Actuation)*

Symbol		Pressure Compensated Flow (Specified flow is at 15 bar pump margin pressure)	
		210 l/min [55.4 US gal/min]	240 l/min [63.4 US gal/min]
4-way, 3 position, Closed Neutral Position		11102188	11102192
Standard Mount			
Option Mount		11102200	11102205
4-way, 3-position, Throttled Open Neutral Position		11102189	11102193
Standard Mount			
Option Mount		11102201	11102206

### High Flow Spools (Hydraulic and Mechanical Actuation) Progressive Flow Characteristics

*High Flow Spools (Hydraulic and Mechanical Actuation)*

Symbol		Pressure Compensated Flow (Specified flow is at 15 bar pump margin pressure)	
		210 l/min [55.4 US gal/min]	240 l/min [63.4 US gal/min]
4-way, 3 position, Closed Neutral Position		11102186	11102190
Standard Mount			
Option Mount		11102198	11102202
4-way, 3-position, Throttled Open Neutral Position		11102187	11102191
Standard Mount			
Option Mount		11102199	11102203

**Modules and code numbers**

**High Flow Spools, Full Open A/B → T and Neutral; Progressive Flow Characteristics**

*High Flow Spools (Hydraulic and Mechanical Actuation)*

Symbol		Pressure Compensated Flow (Specified flow is at 15 bar pump margin pressure)	
		210 l/min [55.4 US gal/min]	240 l/min [63.4 US gal/min]
4-way, 3 position, Closed Neutral Position, Electrical Actuation		11148962	11148961
Standard Mount			
Option Mount		11148951	11148952
4-way, 3 position, Closed Neutral Position, Hydraulic Actuation		11148953	11148954
Standard Mount			
Option Mount		11148955	11148956

**Exposed spools Progressive Flow Characteristics**

The following spools are available with an exposed tang for mechanical actuation. These spools are only available for standard mounting.

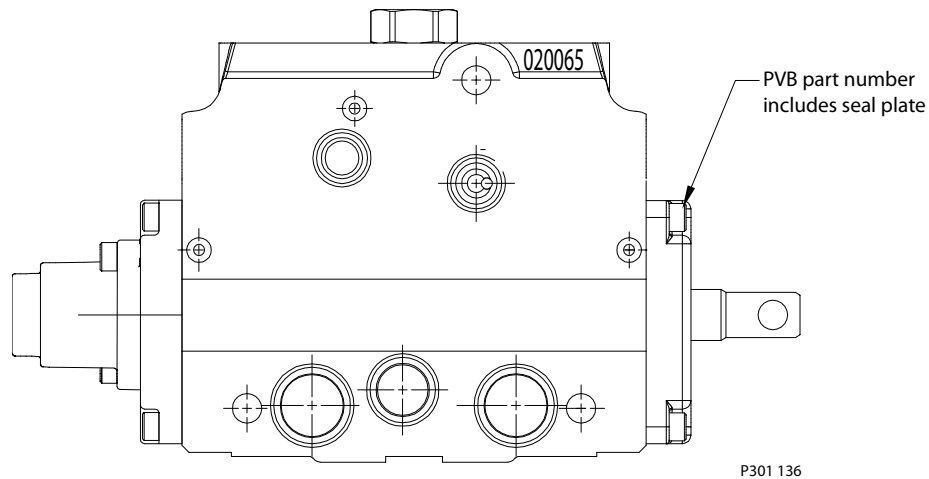

Symbol	Pressure compensated flow l/min [US gal/min]*					
	A 40 [10.6]	B 65 [17.2]	C 100 [26.4]	D 130 [34.4]	E 150 [39.6]	F 180 [47.6]
4-Way, 3-Position, Closed Neutral Position Standard Mount  P301 138	11051695	11051696	11051697	11051698	11051699	11051700
4-Way, 3-Position, Throttled Open Standard Mount  P301 139	11051701	11051702	11051703	11051704	11051705	11051706

**Dimensions**

**PVG 100 dimensions in general**

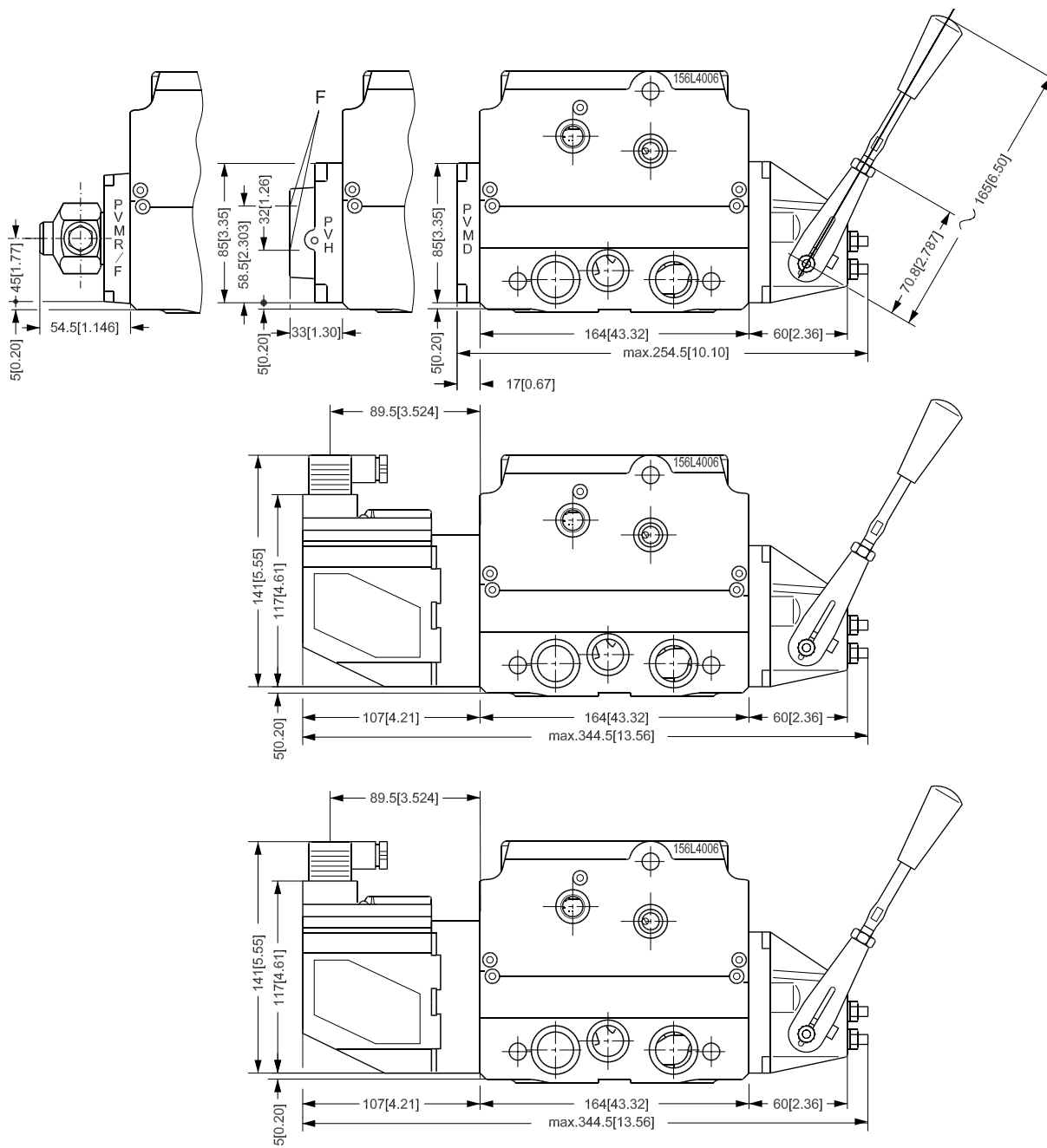

P301 064

**Dimensions**

**PVG 100 with open center PVPF dimensions**

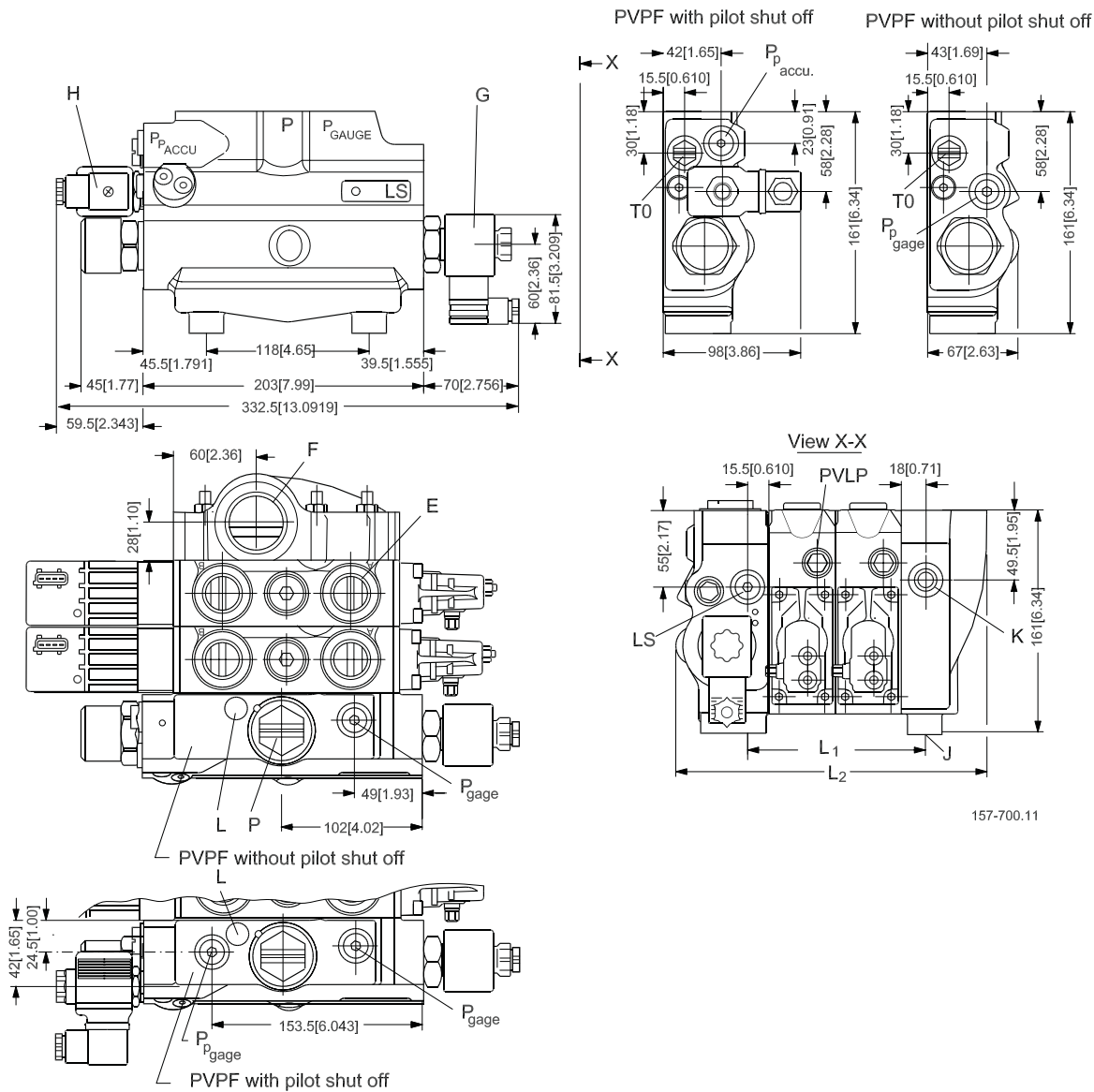

- Pp accumulator: G¼ [9/16 in-18UNF]
- T0 and LS: G¼ [9/16 in-18UNF]
- P and Pp gauge: G¼ [9/16 in-18UNF]
- K: LX: G¼ [9/16 in-18UNF]
- F: Tank port: G1 [15/16 in-12UNF]

- P: Pump port: G1 [15/16 in-12UNF]
- L: LS relief valve
- G: PVPE unloading valve
- H: PVPP pilot shut off valve
- J: Mounting thread; M12 x 14 mm deep

To avoid spool bind or leakage between sections caused by uneven mounting surfaces it is recommended to only use 3 of 4 mounting holes provided.

	1 PVB	2 PVB	3 PVB	4 PVB	5 PVB	6 PVB	7 PVB	8 PVB
L1 mm	80	128	176	224	272	320	368	416
[in]	[3.15]	[5.04]	[6.93]	[8.82]	[10.71]	[12.60]	[14.49]	[16.38]



**Dimensions**

	1 PVB	2 PVB	3 PVB	4 PVB	5 PVB	6 PVB	7 PVB	8 PVB
L2 mm	176	224	272	320	368	416	464	512
[in]	[6.93]	[8.82]	[10.71]	[12.60]	[14.49]	[16.38]	[18.27]	[20.16]

**PVG 100/32, closed center PVPV**

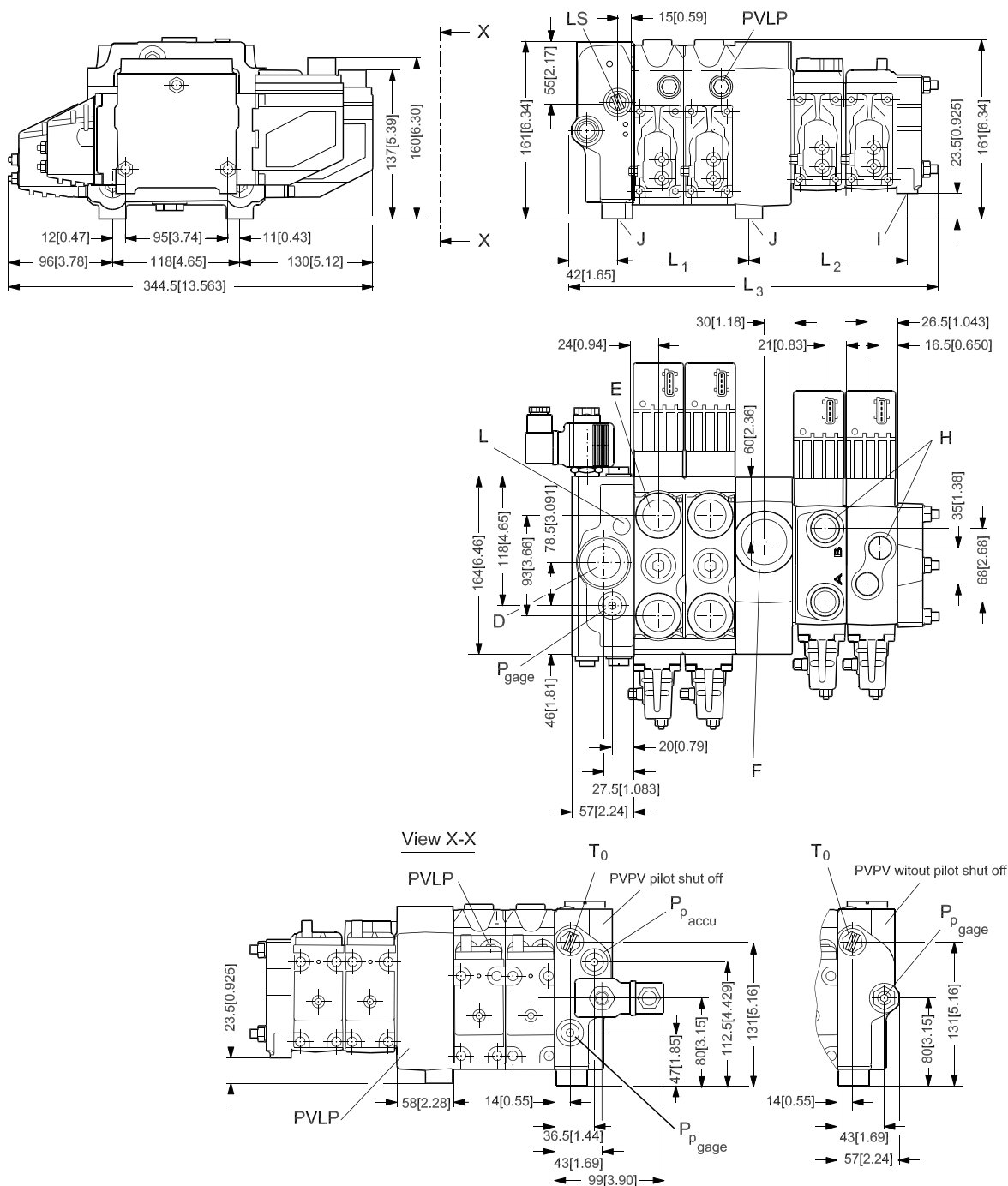

157-701.14

Pp accumulator: G $\frac{1}{4}$  [9/16 in-18UNF]

E: Port A and B PVB 100; G $\frac{3}{4}$  [1 1/16 inin - 12 UNF]

**Dimensions**

T0 and LS: G $\frac{1}{4}$  [9/16 in-18UNF]

P and Pp gauge: G $\frac{1}{4}$  [9/16 in-18UNF]

D: Pump port; G1 [15/16 in-12UNF]

F: Tank port; G1 $\frac{1}{4}$  [15/8 in - 12 UNF]

H : Port A and B PVB 32; G $\frac{1}{2}$  [7/8 in - 14 UNF]

I : Mounting thread ; M8 x 15 mm deep [5/16 in - 18 UNC]

J: Mounting thread; M12 x 14 mm deep

L: LS relief valve

		1 PVB	2 PVB	3 PVB	4 PVB	5 PVB	6 PVB	7 PVB	8 PVB	9 PVB	10 PVB
L1	mm	80	128	176	224	272	320	368	416	-	-
	[in]	[3.15]	[5.04]	[6.93]	[8.82]	[10.71]	[12.60]	[14.49]	[16.38]	-	-
L2	mm	100	148	196	244	292	340	388	436	484	532
	[in]	[3.94]	[5.83]	[7.72]	[9.61]	[11.50]	[13.39]	[15.28]	[17.16]	[19.05]	[20.94]
L3	mm	-	245	293	341	389	437	485	533	581	629
	[in]	-	[9.64]	[11.54]	[13.43]	[15.31]	[17.20]	[19.09]	[20.98]	[22.87]	[24.76]

It is recommended not to exceed 10 PVB 100/32 in a valve group.

**PVG 100, Closed Center PVP with Integrated Priority Valve**

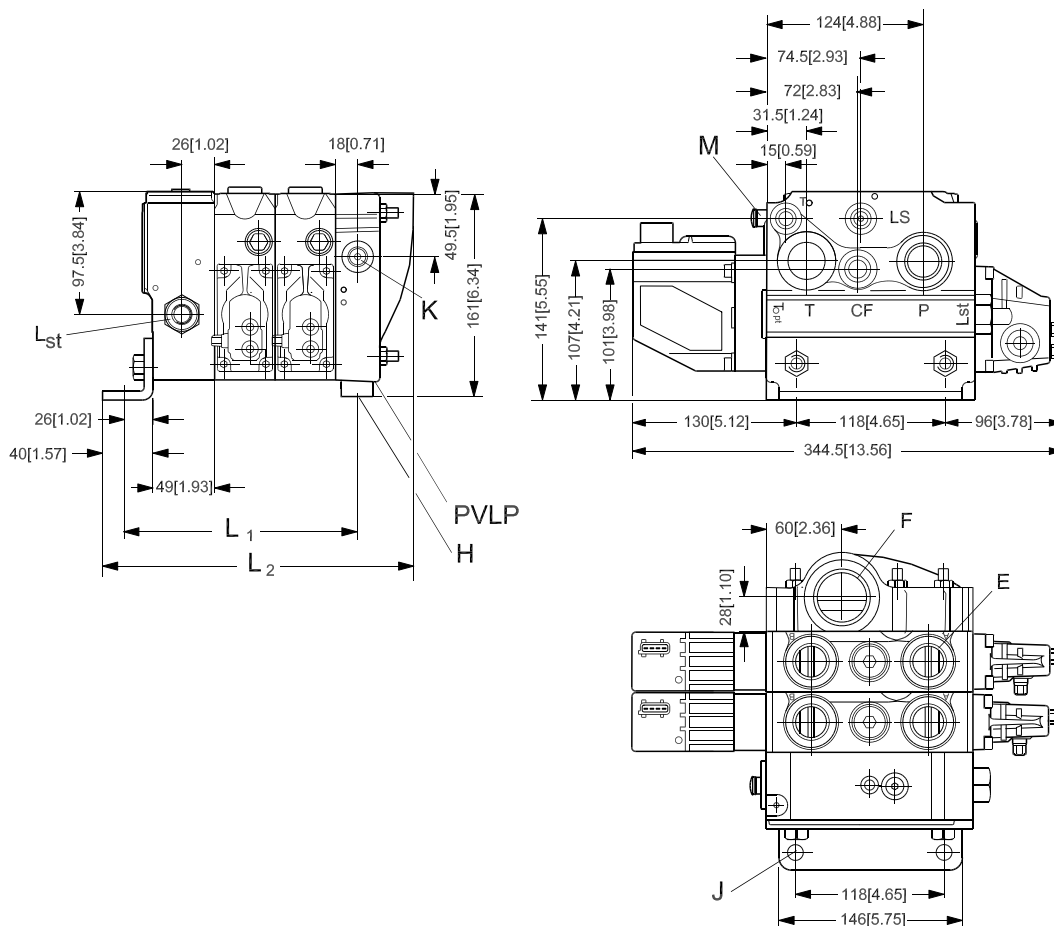

CF: G $\frac{1}{2}$  [¾ in - 16 UNF]

LS: G $\frac{1}{4}$  [9/16 in - 18 UNF]

P gauge: G $\frac{1}{4}$  [7/16 in - 24 UNF]

K: LX connection G $\frac{1}{4}$  [9/16 in - 18 UNF]

L<sub>st</sub>: LS for steering unit; G $\frac{1}{4}$  [9/16 in - 18 UNF]

E: Port A and B PVB 100; G $\frac{3}{4}$  [1 1/16 in - 12 UNF]

Port A and B for High flow PVB G $\frac{3}{4}$  [1 3/16 in - 12 UNF]

Technical Information  
**PVG 100 Proportional Valve Group**

**Dimensions**

T0 port: G¼ [9/16 in - 18 UNF]  
 Pp gauge: G¼ [7/16 in - 24 UNF]  
 P pump: G¾ [1 1/16 in - 12 UNF]  
 F: G¼ [1 1/16 in]

H: Mounting thread M12 x 14 mm deep  
 J: Mounting bracket with holes for M12 screws  
 M: LS relief valve

		1 PVB	2 PVB	3 PVB	4 PVB	5 PVB	6 PVB	7 PVB	8 PVB
L1	mm	140	188	236	284	332	380	428	476
	[in]	[5.51]	[5.12]	[9.29]	[11.18]	[9.13]	[14.96]	[16.85]	[18.74]
L2	mm	198	246	294	342	390	438	486	534
	[in]	[7.80]	[9.69]	[11.57]	[13.46]	[15.35]	[17.24]	[19.13]	[21.02]

**Examples**

**PVG 100 with variable displ. pump**

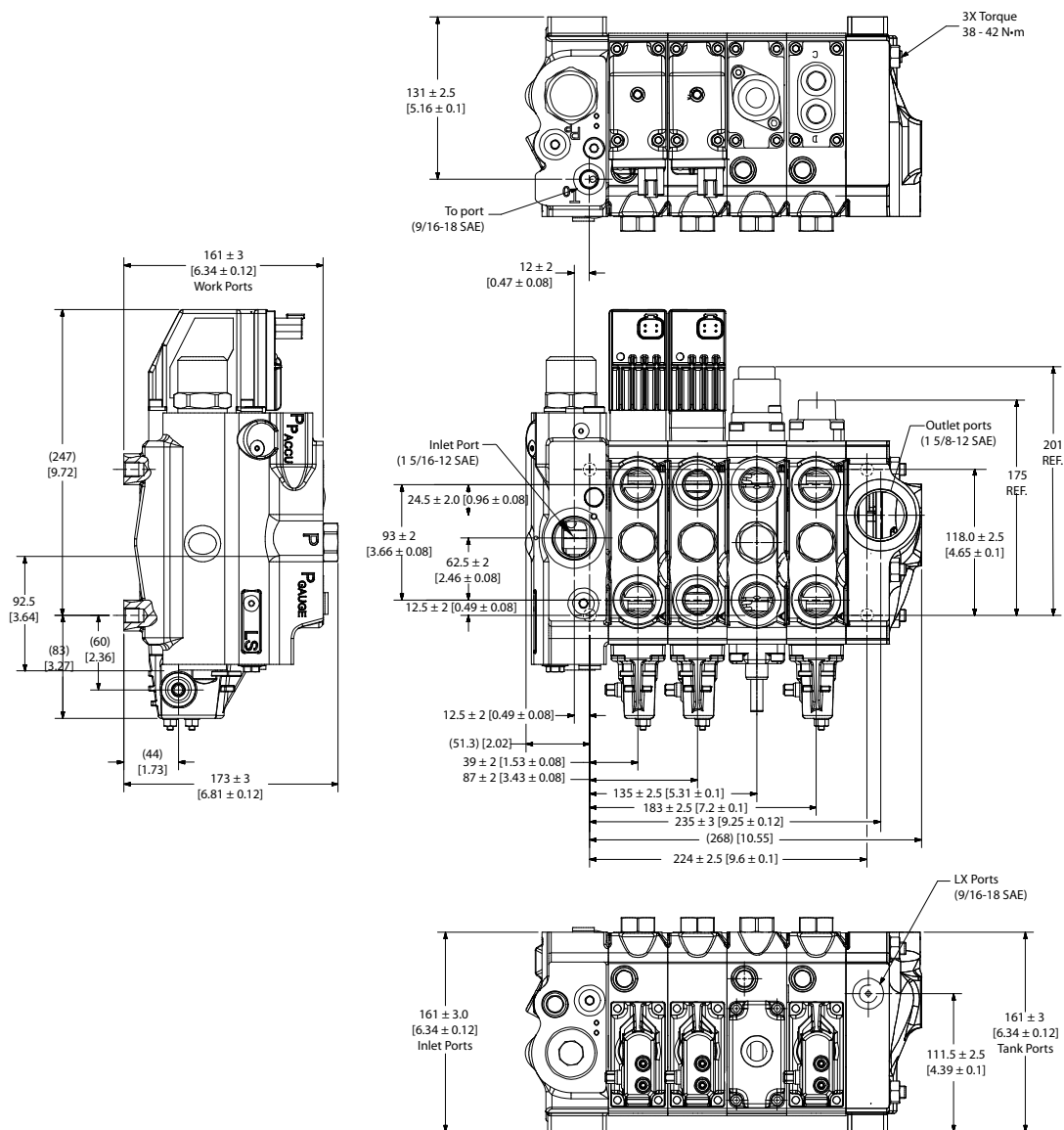

P301 140E

**Dimensions**

**PVPVM with two PVT modules**

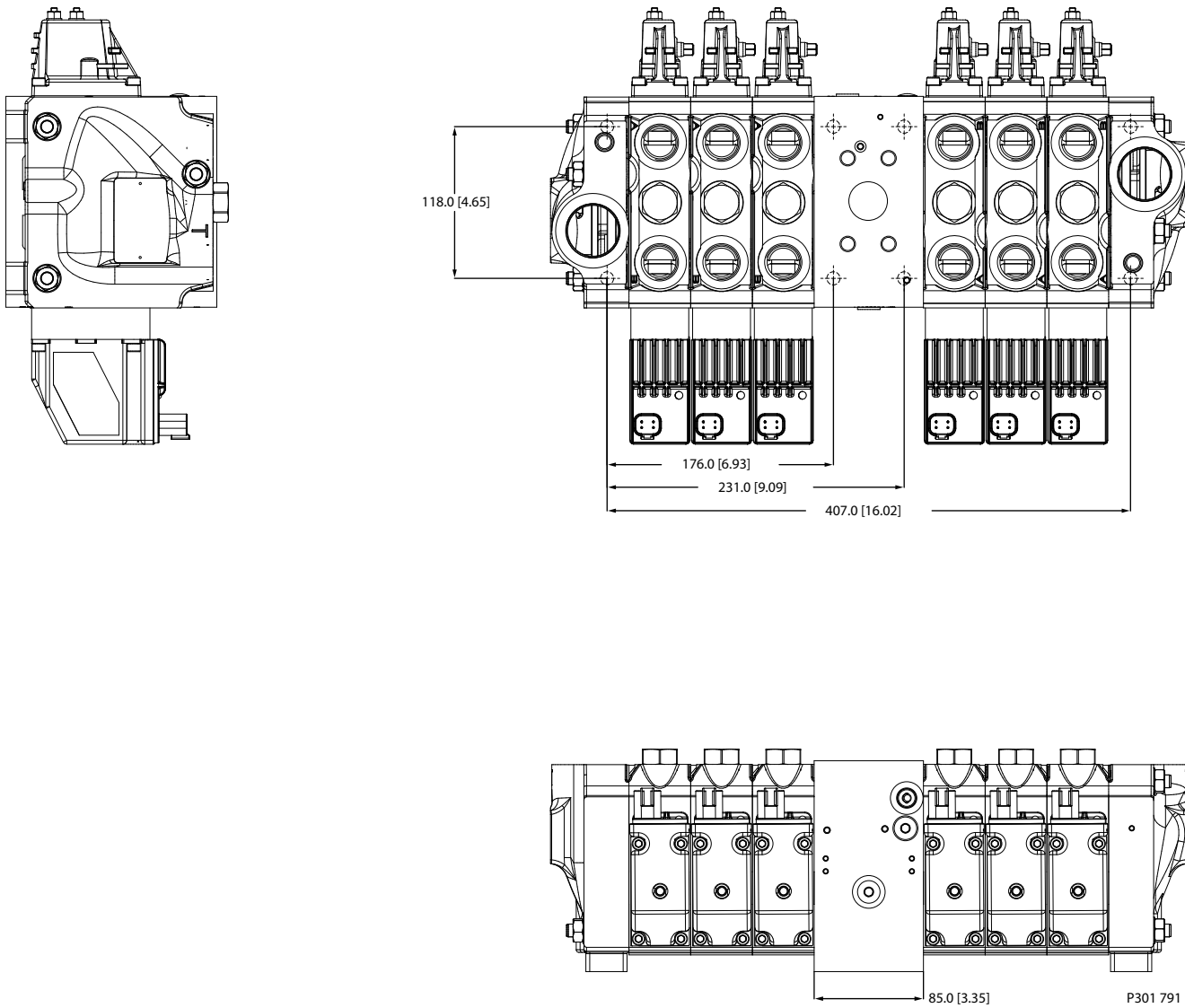

**Dimensions**

**PVPVM with one PVT and one PVBE**

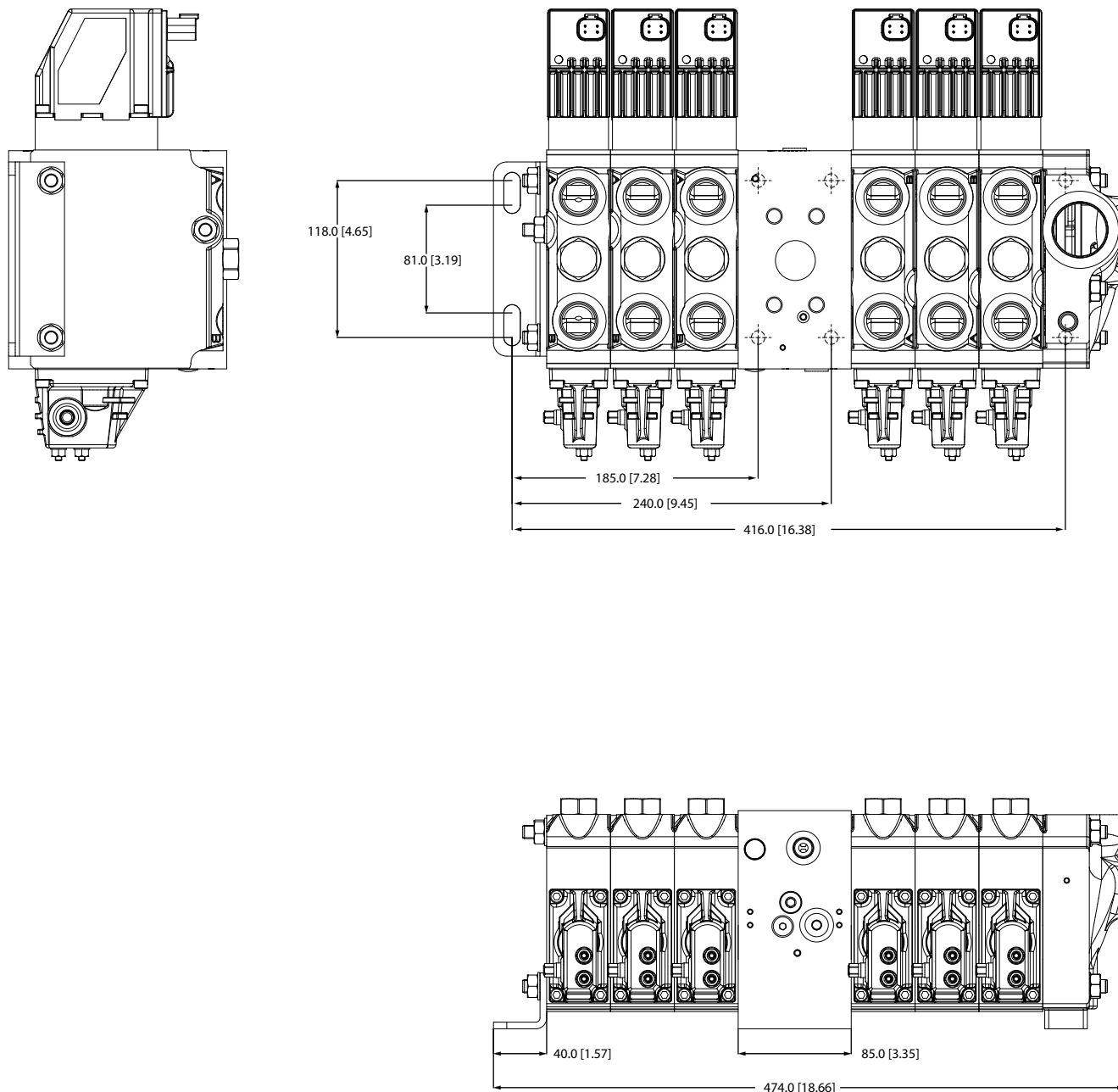

**Dimensions**

**High Flow PVB module**

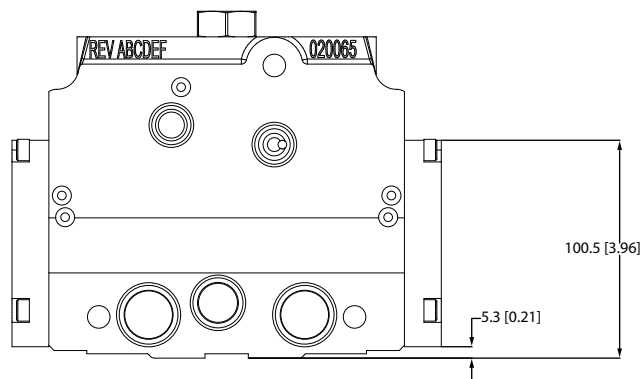
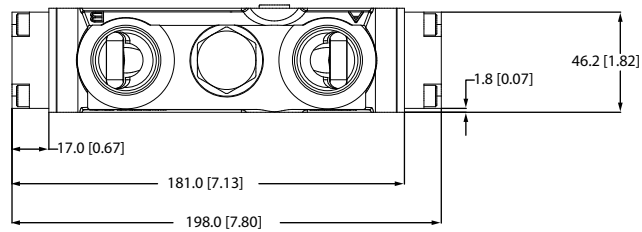

P301 793

**PVBE mounting bracket**

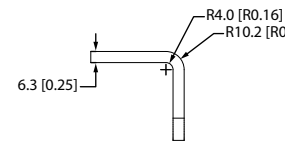
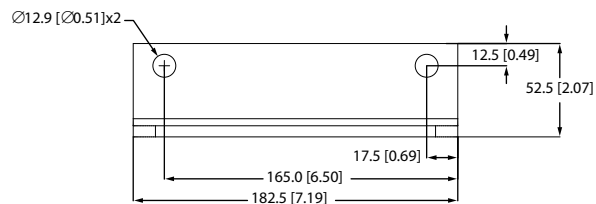
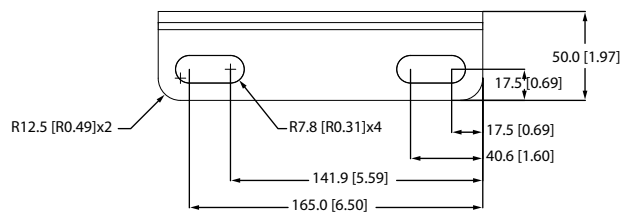

P301 794

**Dimensions**

**PVBSO module**

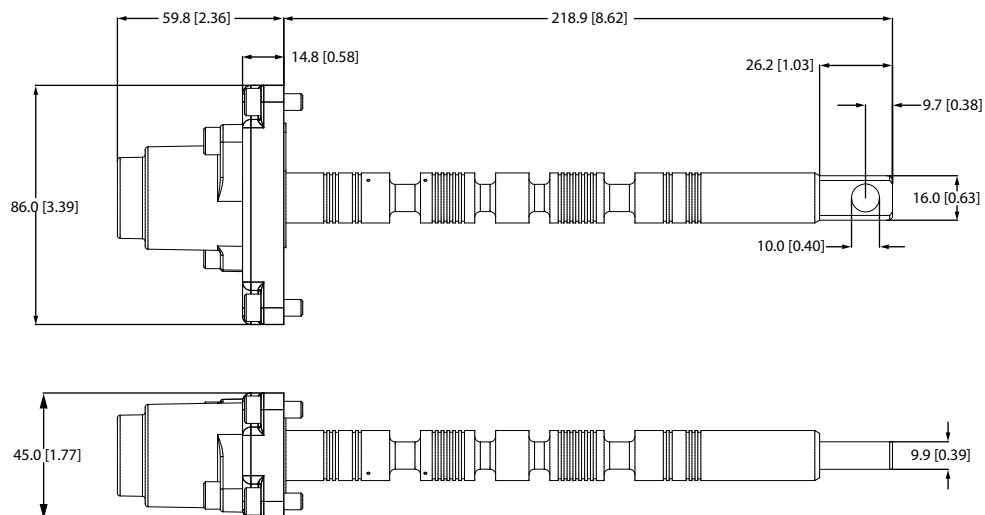

P301 795

**Module selection chart**

**Exploded view for module selection**

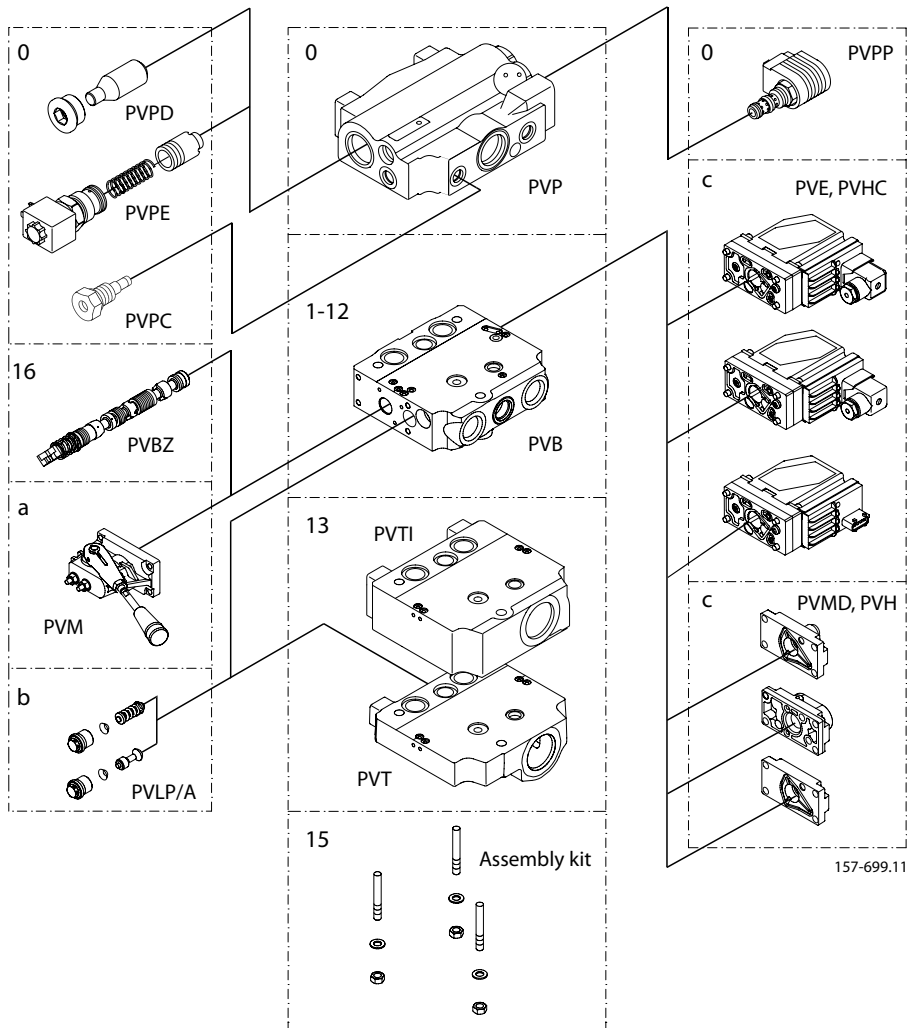

*PVP 100, Pump Side Module – Open center, PVPF with pilot supply (excludes PVPD/PVPE)*

Port (includes pilot gauge port)	Open center, PVPF with pilot supply							
	for PVE		for PVE and facility for pilot shut off		for PVH/PVHC		for PVH/PVHC and facility for pilot shut off	
	12 bar	20 bar	12 bar	20 bar	12 bar	20 bar	12 bar	20 bar
P = G 1	161B5110	161B5112	161B5140	161B5142	11013065	11013067	11013071	11013073
P = 15/16 UNF	161B5510	161B5512	161B5540	161B5542	11013066	11013068	11013072	11013074
Weight	8.5 kg [12.3 lb]							

*PVP 100, Pump Side Module – Closed center, PVPV with pilot supply*

Port (includes pilot gauge port)	Closed center, PVPV with pilot supply					
	for PVE	for PVE and facility for pilot shut-off	for PVE with integrated priority function	for PVH/PVHC	for PVH/PVHC and facility for pilot shut-off	for PVH/PVHC with integrated priority function
P = G 1	161B5111	161B5141	-	11013069	11013075	-
P = 1 $\frac{5}{16}$ UNF	161B5511	161B5541	-	11013070	11013076	-



### Module selection chart

*PVP 100, Pump Side Module – Closed center, PVPV with pilot supply (continued)*

Port (includes pilot gauge port)	Closed center, PVPV with pilot supply					
	for PVE	for PVE and facility for pilot shut-off	for PVE with integrated priority function	for PVH/PVHC	for PVH/PVHC and facility for pilot shut-off	for PVH/PVHC with integrated priority function
P = G ¾; T = G 1	-	-	161B5211	-	-	11013077
P = G 1 1/16 UNF; T = 1 5/16 UNF	-	-	161B5611	-	-	11013078
Weight	8.5 kg [12.3 lb]					

*PVP 100, Pump Side Module – Mid Inlet, PVPVM with pilot supply*

Port	Closed center, PVPVM with pilot supply	
	for PVE	for PVH/PVHC
P = 1 ¼ in Metric flange BSP	11130086	11133046
P = 1 ¼ in Metric flange SAE	11133048	11133047

*PVB, Basic Module*

Code no.	Without facilities for shock valves A and B		With facilities for shock valves A and B	
	G ¾	1 1/16-12 UNF	G ¾	1 1/16-12 UNF
Without pilot operated check valve	161B6250	161B6650	161B6260	161B6660
With pilot operated check valve	161B6252	161B6652	161B6262	161B6662
Open spools PVB	11051707	11051708	11051709	11051710
Open spools PVBZ	11051711	11051712	11051713	11051714
End module	-	11036948	11006889	11070866
Module with tank port in bottom	-	-	11006887	-
PVB module, twin shock valve	-	-	-	11077581
Weight	kg [lb]	5.5 kg [12.13 lb]		

*PVB, Basic Module – High Flow 20 mm*

Code no.	Without facilities for shock valves A and B		With facilities for shock valves A and B	
	G ¾	1 3/16-12 UNF	G ¾	1 3/16-12 UNF
Without pilot operated check valve	11102180	11102181	11102178	11101825
With pilot operated check valve	11102184	11102185	11102182	11102183

*PVP, Accessory Module for PVP 100*

Code no.	Weight
Plug, PVPD	155G5041* 0.4 kg [0.9 lb]

\* For PVPF only

*PVPE, Accessory Module for PVP 100*

Code no.	12 V	24 V	Weight
PVPE, Elec. unloading valve	155G5052*	155G5054**	0.7 kg [1.1 lb]
PVPH, hydraulic unloading valve	155G5061		

\* For PVPF only

### Module selection chart

#### PVPC, External pilot supply

Code no.	G $\frac{1}{4}$	7/16-20 UNF	1/2-20 UNF	Weight
Without check valve	157B5400	158X1000	-	0.05 kg [0.1 lb]
With check valve	157B5600	-	157B5700	

Not available for PVPV 157B5211 and 157B5611, (for details see catalog, 520L0344)

#### PVM, mechanical actuation

Code No.	With stop screw	Without stop screw	Lever position angle
Standard	157B3171* 157B3161**	157B3191	22.5°
Standard, with base, without arm and button	157B3174 157B3175	157B3194 157B3192	37.5°
Standard, without base, arm and button	157B3173 157B3172	157B3193 157B3195	- -
Weight kg [lb]	0.4 [0.9]		

\* Anodized 157B3184

\*\* Cast iron

#### PVB, PVBZ Spools

Code no.	Without facilities for shock valves A and B		With facilities for shock valves A and B	
	G $\frac{3}{4}$	1 1/16-12	G $\frac{3}{4}$	1 1/16-12
Open spools PVB	11051707	11051708	11051709	11051710
Open spools PVBZ	11051711	11051712	11051713	11051714

#### PVLA, Anti-Cavitation Valve

PVLA	Code No.	Weight
Cap A or B	157B2002	0.04 kg [0.09 lb]
Valve A or B	157B2001	0.05 kg [0.1 lb]

#### PVLP, shock/and anti-cavitation valves

Code no. 157B....	2032	2050	2063	2080	2100	2125	2140	2150	2160	2175	
Setting	bar	32	50	63	80	100	125	140	150	160	175
	[psi]	[460]	[725]	[914]	[1160]	[1450]	[1813]	[2031]	[2175]	[2320]	[2538]
Weight kg [lb]	0.05 kg [17 lb]										

#### PVLP, shock/and anti-cavitation valves

Code no. 157B....	2190	2210	2230	2240	2250	2265	2280	2300	2320	2350	
Setting	bar	190	210	230	240	250	265	280	300	320	350
	[psi]	[2755]	[3045]	[3335]	[3480]	[3625]	[3845]	[4061]	[4351]	[4641]	[5075]
Weight kg [lb]	0.05 kg [17 lb]										

### Module selection chart

#### Accessory Module for PVP 100

Code no.	12 V	24 V	Weight
PVPP, Pilot shut off valve	11160318	11160319	0.3 kg [0.7 lb]

#### PVE, Electrical Actuation

Code No.		Hirsch	AMP	DEUTSCH	Weight
PVEO, ON/OFF	12 V	157B4216	157B4901	157B4291	0.6 kg [1.3 lb]
	24 V	157B4228	157B4902	157B4292	
PVEO, ON/OFF Anodised	12 V	157B4266	-	-	
	24 V	157B4268	157B4272	-	
PVEO-R, ON/OFF	12 V	157B4217	157B4903	11109080	
	24 V	157B4229	157B4904	11109092	
PVEA, active fault mon. PVEA, passive fault mon.*		-	157B4734	157B4792	0.9 kg [2 lb]
		-	157B4735	11107365	
PVEA-DI, active fault mon. PVEA-DI, passive fault mon.*		-	157B4736	157B4796	
		-	157B4737	-	
PVEH active fault mon. PVEH passive fault mon. PVEH passive fault mon. (anodized)		157B4032	157B4034	157B4092	1 kg [2.2 lb]
		157B4033	157B4035	157B4093	
		157B4073	157B4075		
PVEH-F float pos.		157B4332	-	157B4392	
PVEH-DI active fault mon. PVEH-DI passive fault mon.		-	157B4036	157B4096	
		-	157B4037	-	
PVEP active fault mon.		-	-	11034832	
PVES, active fault mon. PVES, passive fault mon.		157B4832	157B4834	157B4892	
		157B4833	157B4835	11089276	
PVED-CC, Can-Bus interface		-	11079034	11079033	

\* PVEA with flows over 130 l/min [34.3 US gal/min] may not shift spool to full stroke

[Refer to catalog 520L0553 for more PVE information](#)

#### PVHC, High Current PWM Actuator

Code No.	12 V	24 V
Amp	11112037	11112036
Deutsch	11112038	11112039

#### PVMD, PVH, PVMR, PVMF Covers

Code No.			Weight	
Cover for PVM		157B0001	0.1 kg	[0.2 lb]
Cover for Hydraulic Remote Control		157B0021		
PVH, Hydraulic actuation	G 1/4	157B0008	0.2 kg	[0.4 lb]
	9/16 -18 UNF	157B0007	0.9 kg	[2.0 lb]
PVMR (friction detent)		157B0015	0.3 kg	[0.6 lb]
PVMF (mech. float position)		157B0005		

#### PVTI 100/32 interface module

Code no.	BSP	SAE	Weight
PVTI, with T-port and PVLP facility	161B2200	161B2220	8.7 kg [19.18 lb]

T-connection G 1¼ [158 UNF]

### Module selection chart

#### Tank Module, PVT

Code no.	BSP	SAE	Weight
PVT, with T-port and PVLP facility	161B2500	161B2520	6.3 kg [13.89 lb]
PVT, with LX connection, T-port and PVLP facility	161B2505	161B2525	

T-connection G 1¼ [15/8 UNF]

#### Assembly Kit PVG 100 / PVT

Description	Code No.							
	1 PVB	2 PVB	3 PVB	4 PVB	5 PVB	6 PVB	7 PVB	8 PVB
Tie bolts and seals	161B8001	161B8002	161B8003	161B8004	161B8005	161B8006	161B8007	161B8008

#### Assembly Kit PVG 100 / PVTI Interface Module

Description	Code No.								
	0 PVB	1 PVB	2 PVB	3 PVB	4 PVB	5 PVB	6 PVB	7 PVB	8 PVB
Tie bolts and seals	11143008	161B8021	161B8022	161B8023	161B8024	161B8025	161B8026	161B8027	161B8028

#### Assembly Kit PVG100 for PVB End module (must be used with bottom tank ported PVB)

Description	Code No.							
	1 PVB	2 PVB	3 PVB	4 PVB	5 PVB	6 PVB	7 PVB	8 PVB
Tie bolts and seals	11081671	11017005	11017006	11017007	11017008	11017009	11017010	11017011

#### Assembly Kit PVB 32

Description	Code No.									
	1 PVB	2 PVB	3 PVB	4 PVB	5 PVB	6 PVB	7 PVB	8 PVB	9 PVB	10 PVB
PVB's	157B8000	157B8001	157B8002	157B8003	157B8004	157B8005	157B8006	157B8007	157B8008	157B8009
Weight [kg [lb]]	0.1 [0.2]	0.15 [0.3]	0.25 [0.6]	0.3 [0.7]	0.4 [0.9]	0.45 [1]	0.5 [1.1]	0.6 [1.3]	0.65 [1.4]	0.7 [1.6]

## PVG 100 order specification

The PVG 100 Inlet LS relief valve (1) is specifically designed to ensure a constant margin pressure across the main spool, providing demanded regulated flow during maximum load pressure conditions. This relief adjustment is critical when there are two or more functions being operated together. An incorrectly adjusted Inlet relief could result in a vast reduction in regulated flow from the adjacent functions that operate at a lower load pressure. To accurately adjust the inlet LS relief, the pump standby pressure must be known in addition to the maximum operating load pressure.

### Example

Pressure comp pressure level	172 bar [2500 psi]
LS standby pressure requirement that delivers the desired flow	-20 bar [-290 psi]
Maximum load pressure requirement	152 bar [2210 psi]
Inlet relief pressure setting	152 bar [2210 psi]

An order form for Danfoss PVG 100 hydraulic valve is shown on the next page. The form can be obtained from the Danfoss Sales Organization.

Both the module selection chart on the previous pages and the order form are divided into fields 0, 1-10, 11, 12, 13, a, b, and c.

Each module has its own field:

- 0:** Pump side module PVP
  - Plug for external pilot oil supply PVPC
  - Electrical unloading valve PVPE
  - Electrical pilot shut off valve PVPE
  
- 1-10:** Basic valves PVB
- 13:** Main spool PVBS
  - a:** Mechanical actuator PVM
  - c:** Cover for mechanical actuation PVMD  
Cover for hydraulic actuation PVH  
Electrical actuators PVE
  - b:** Shock and suction valve PVLV  
Suction valve PVLA
  
- 11:** End plate PVSI  
Tank module PVT  
Interface module PVTI
- 12:** Assembly kit PVAS

### Please state

- Code numbers of all modules required
- Required setting (P) for pump side module

### Standard and option assembly

The valve group is assembled the way the module selection chart shows if the code number for PVM is written in field 'a', and the code number for PVMD, PVE or PVH in field 'c'.

**PVG 100 order specification**

The valve group is assembled so that the mechanical actuator is mounted on the opposite end of the basic module, if the code number for PVM is written in field 'c' of the order form and the code numbers for PVMD, PVE or PVH in field 'a'.

**Reordering**

The space at the top right-hand corner of the form is for Danfoss to fill in. The code number for the whole of the specified valve group (PVG No.) is entered here.

In the event of a repeat order all you have to do is enter the number Danfoss has given on the initial confirmation of order.

**Specification sheet**

**Specification form**



**PVG 100  
 Specification Sheet**

Subsidiary / Dealer	PVG No.
Customer	Customer No.
Application	Revision No.

Function		A-port	B-port
0	Inlet	161B P = bar	
1	a	f 13	c
	b	LS <sub>A</sub> = bar LS <sub>B</sub> = bar	b
2	a	f 13	c
	b	LS <sub>A</sub> = bar LS <sub>B</sub> = bar	b
3	a	f 13	c
	b	LS <sub>A</sub> = bar LS <sub>B</sub> = bar	b
4	a	f 13	c
	b	LS <sub>A</sub> = bar LS <sub>B</sub> = bar	b
5	a	f 13	c
	b	LS <sub>A</sub> = bar LS <sub>B</sub> = bar	b
6	a	f 13	c
	b	LS <sub>A</sub> = bar LS <sub>B</sub> = bar	b
7	a	f 13	c
	b	LS <sub>A</sub> = bar LS <sub>B</sub> = bar	b
8	a	f 13	c
	b	LS <sub>A</sub> = bar LS <sub>B</sub> = bar	b
9	a	f 13	c
	b	LS <sub>A</sub> = bar LS <sub>B</sub> = bar	b
10	a	f 13	c
	b	LS <sub>A</sub> = bar LS <sub>B</sub> = bar	b
11	a	f 13	c
	b	LS <sub>A</sub> = bar LS <sub>B</sub> = bar	b
12	a	f 13	c
	b	LS <sub>A</sub> = bar LS <sub>B</sub> = bar	b
13	End section		
14	PVAS section		

Comments	
Filled in by	Date

Specification sheet

Specification example for PVPVM

Customer		Application		PVG PN	
				Subsidiary / Dealer:	
		<b>PVG Specification</b> <b>PVG100</b>		X	
Function	A - Port			B - Port	
↓	↓	0	11144936 Mounting		
			p= bar	11017006 PVAS PVI	
a	157B3171 PVM	1	11036948 PVBE SAI	11013084 SPOOL 11	16 157B4092 PVEH.(G) a
b			LS <sub>A</sub> bar	LS <sub>B</sub> bar	b
b					b
a	157B3171 PVM	2	161B6650 PVB	11013084 SPOOL 11	16 157B4092 PVEH.(G) a
b			LS <sub>A</sub> bar	LS <sub>B</sub> bar	b
b					b
a	157B3171 PVM	3	161B6650 PVB	11013084 SPOOL 11	16 157B4092 PVEH.(G) a
b			LS <sub>A</sub> bar	LS <sub>B</sub> bar	b
b					b
a		4	11133048 PVPVM1C		16 a
b			LS <sub>A</sub> bar	LS <sub>B</sub> bar	b
b					b
a	157B3171 PVM	5	161B6650 PVB	161B7027 PVBS	16 157B4092 PVEH.(G) a
b			LS <sub>A</sub> bar	LS <sub>B</sub> bar	b
b					b
a	157B3171 PVM	6	161B6650 PVB	161B7027 PVBS	16 157B4092 PVEH.(G) a
b			LS <sub>A</sub> bar	LS <sub>B</sub> bar	b
b					b
a	157B3171 PVM	7	161B6650 PVB	161B7027 PVBS	16 157B4092 PVEH.(G) a
b			LS <sub>A</sub> bar	LS <sub>B</sub> bar	b
b					b
a		8			16 a
b			LS <sub>A</sub> bar	LS <sub>B</sub> bar	b
b					b
a		9			16 a
b			LS <sub>A</sub> bar	LS <sub>B</sub> bar	b
b					b
a		10			16 a
b			LS <sub>A</sub> bar	LS <sub>B</sub> bar	b
b					b
a		11			16 a
b			LS <sub>A</sub> bar	LS <sub>B</sub> bar	b
b					b
a		12			16 a
b			LS <sub>A</sub> bar	LS <sub>B</sub> bar	b
b					b
		13	161B2520 PVT	157B2300 PVL P	b
BUSINESS TYPE		14			
EAU		15	161B8003 PVAS		
Filled in by:		Date:			

P301 799









**Products we offer:**

- DCV directional control valves
- Electric converters
- Electric machines
- Electric motors
- Hydrostatic motors
- Hydrostatic pumps
- Orbital motors
- PLUS+1® controllers
- PLUS+1® displays
- PLUS+1® joysticks and pedals
- PLUS+1® operator interfaces
- PLUS+1® sensors
- PLUS+1® software
- PLUS+1® software services, support and training
- Position controls and sensors
- PVG proportional valves
- Steering components and systems
- Telematics

**Danfoss Power Solutions** is a global manufacturer and supplier of high-quality hydraulic and electric components. We specialize in providing state-of-the-art technology and solutions that excel in the harsh operating conditions of the mobile off-highway market as well as the marine sector. Building on our extensive applications expertise, we work closely with you to ensure exceptional performance for a broad range of applications. We help you and other customers around the world speed up system development, reduce costs and bring vehicles and vessels to market faster.

Danfoss Power Solutions – your strongest partner in mobile hydraulics and mobile electrification.

**Go to [www.danfoss.com](http://www.danfoss.com) for further product information.**

We offer you expert worldwide support for ensuring the best possible solutions for outstanding performance. And with an extensive network of Global Service Partners, we also provide you with comprehensive global service for all of our components.

**Comatrol**

[www.comatrol.com](http://www.comatrol.com)

**Turolla**

[www.turollaocg.com](http://www.turollaocg.com)

**Hydro-Gear**

[www.hydro-gear.com](http://www.hydro-gear.com)

**Daikin-Sauer-Danfoss**

[www.daikin-sauer-danfoss.com](http://www.daikin-sauer-danfoss.com)

Local address:

**Danfoss  
Power Solutions (US) Company**  
2800 East 13th Street  
Ames, IA 50010, USA  
Phone: +1 515 239 6000

**Danfoss  
Power Solutions GmbH & Co. OHG**  
Krokamp 35  
D-24539 Neumünster, Germany  
Phone: +49 4321 871 0

**Danfoss  
Power Solutions ApS**  
Nordborgvej 81  
DK-6430 Nordborg, Denmark  
Phone: +45 7488 2222

**Danfoss  
Power Solutions Trading  
(Shanghai) Co., Ltd.**  
Building #22, No. 1000 Jin Hai Rd  
Jin Qiao, Pudong New District  
Shanghai, China 201206  
Phone: +86 21 3418 5200

Danfoss can accept no responsibility for possible errors in catalogues, brochures and other printed material. Danfoss reserves the right to alter its products without notice. This also applies to products already on order provided that such alterations can be made without subsequent changes being necessary in specifications already agreed. All trademarks in this material are property of the respective companies. Danfoss and the Danfoss logotype are trademarks of Danfoss A/S. All rights reserved.