

DOUBLE JU INTERNATIONAL Ltd.

Distribution of BARTHOLOMY Reel Handling Units



BARTHOLOMY SW SELF-REEL-TURNER



SW

Product features:

- simple operation
- pulley mechanic
- reel always balanced
- installation to go, hook up and ready to use

Reel data:

- Reel weight,
standard: 100, 150, 250,
400, 600, 800 kg,
Gmax: 800 kg
- Reel diameter
Dmax: 1.200 mm
- Reel width,
Bmax: 1.200 mm
- Gripper:
standard 70, 76,2 and
150, 152,4 mm
- Available gripper
for core: 30 - 650 mm
- Other dimension on request

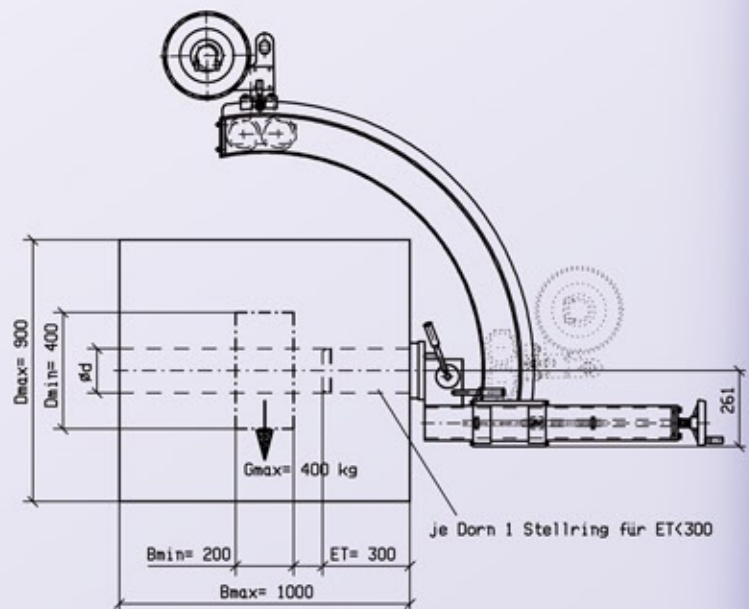

Hülseninnen- ϕ d : ϕ 76,2 mm (3") / ϕ 152,4 mm (6")

Sample drawing SW 400

A working operation is shown on the back

DOUBLE JU INTERNATIONAL Ltd.

Distribution of BARTHOLOMY Reel Handling Units



Working operation BARTHOLOMY SW SELF-REEL-TURNER:



1. Inserting



2. Set down



3. Lifting,
gripping acts automatically



4. Turning



5. Set down

6. Removal