



# KRACHT®

- | Gear Pumps
- | Flow Measurement
- | Hydraulics
- | Valves

Valve Position Indicator  
**VOLUME C**

Valve Position  
Measuring Instrument  
**VOLUTRONIC®**



## Valve Position Indicator 02 /04

### Description

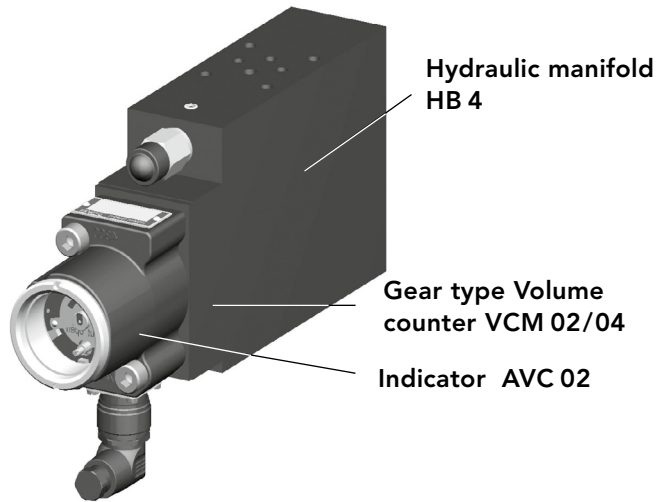

The Valve Position Indicator VOLUMEC is a combination unit with mounting surface for directional control valves NG 06 according to ISO 4401-03-02-0-02 / DIN 24340-A6.

In detail the module consists of a hydraulic manifold, a gear type volume counter and an indicator.

Mounted on a connection plate and completed by a directional control valve the VOLUMEC enables to control hydraulic operating ship armatures for ballast-, cargo- and stripping systems of all kind of tankers. In addition to that the adjusting path of the armature will be measured and displayed.

The Valve Position Indicator is suitable for the installation into deck boxes. The indication of the volumetric entered armature position can be read off optically locally or can be taken electrically by potentiometers or open / closed switches.

### Modular design

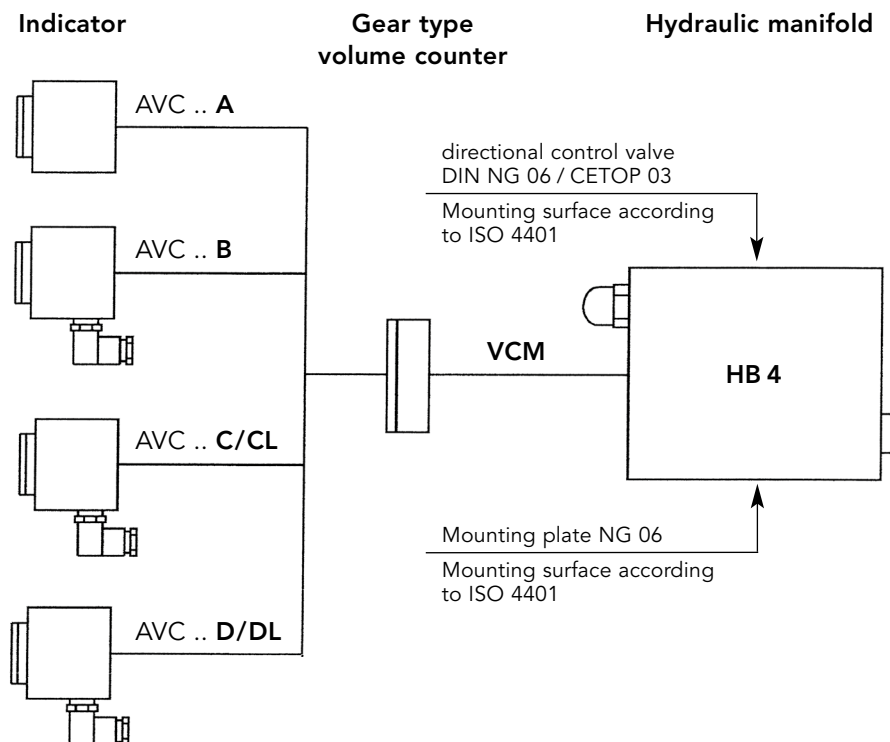

#### VOLUMEC Indicator

- AVC .. A      Optically
- AVC .. B      Open/close switches
- AVC .. C/CL   Potentiometer
- AVC .. D/DL   Open/close switches and potentiometer

## Valve Position Indicator 02 /04

### Application examples

#### Application examples

for 4/3 directional valves spring centred (function 0311)

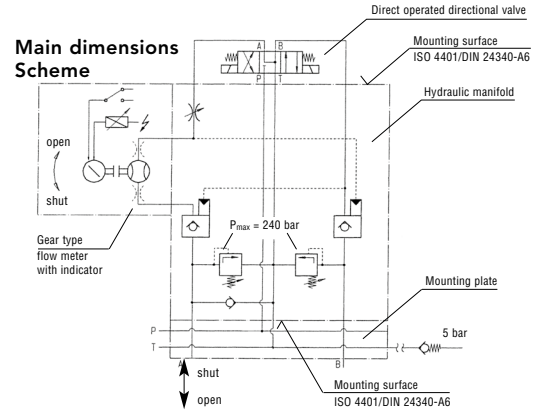
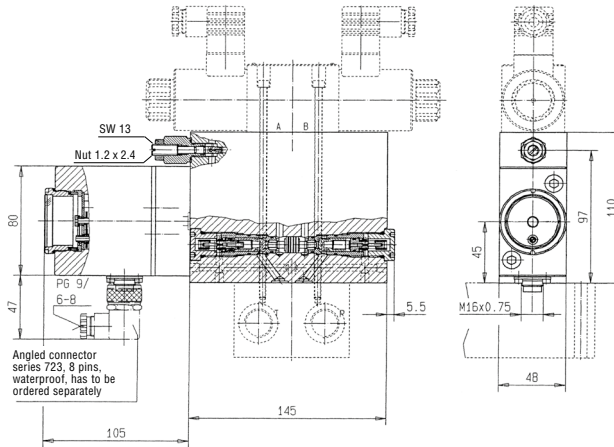

#### Application examples

for 4/2 directional valves spring return (function 0324)

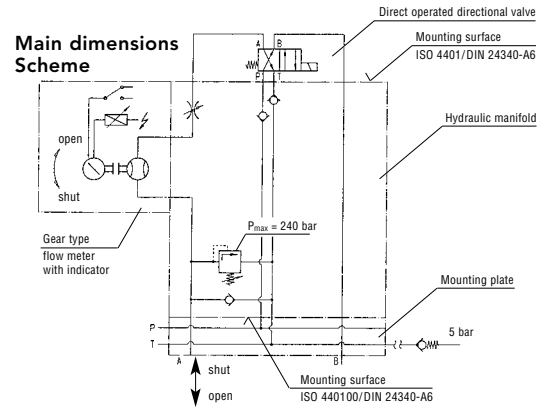
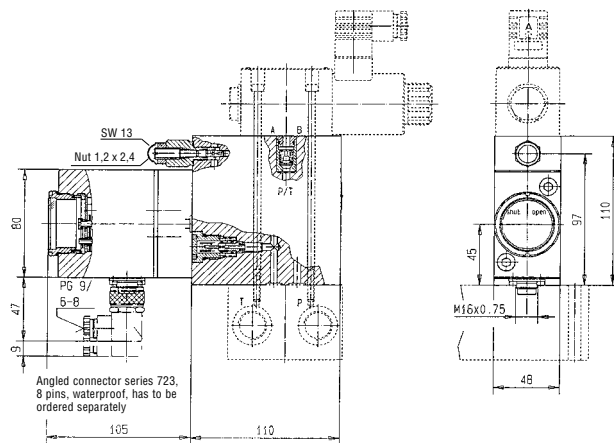

#### Application examples

for 4/2 directional valves with detend (function 0324)

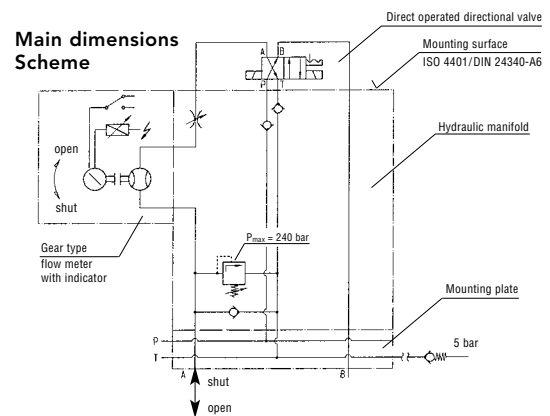
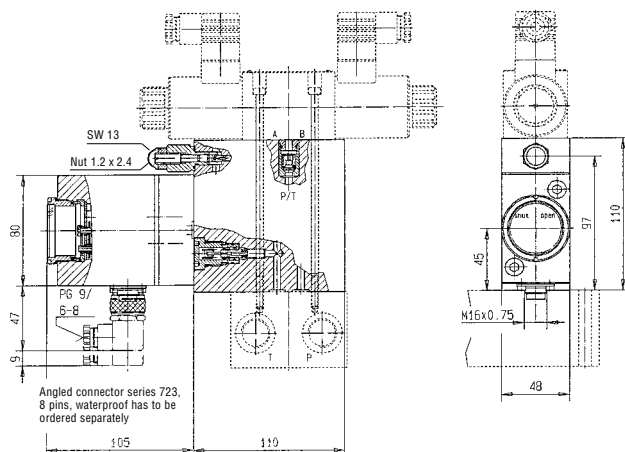

## Indicator AVC 02

### Function

Together with the gear type volume counter the indicator builds the measuring unit. The turning of the gear wheels is transferred via a magnetic drive to the gear box of the indicator. For each application the turndown ratio of the gear box is configured to get a pointer movement of approx. 180°. The pointer is limited by two end stops. To reset the indication at each end position a slipping clutch is integrated.

The driving shaft of the magnetic drive is equipped with a small indication to recognize the movement of the gear wheels. It can be used as leakage detection.

The indicator is completely separated from the hydraulic circuit.

### Type key – Indicator

#### Ordering example

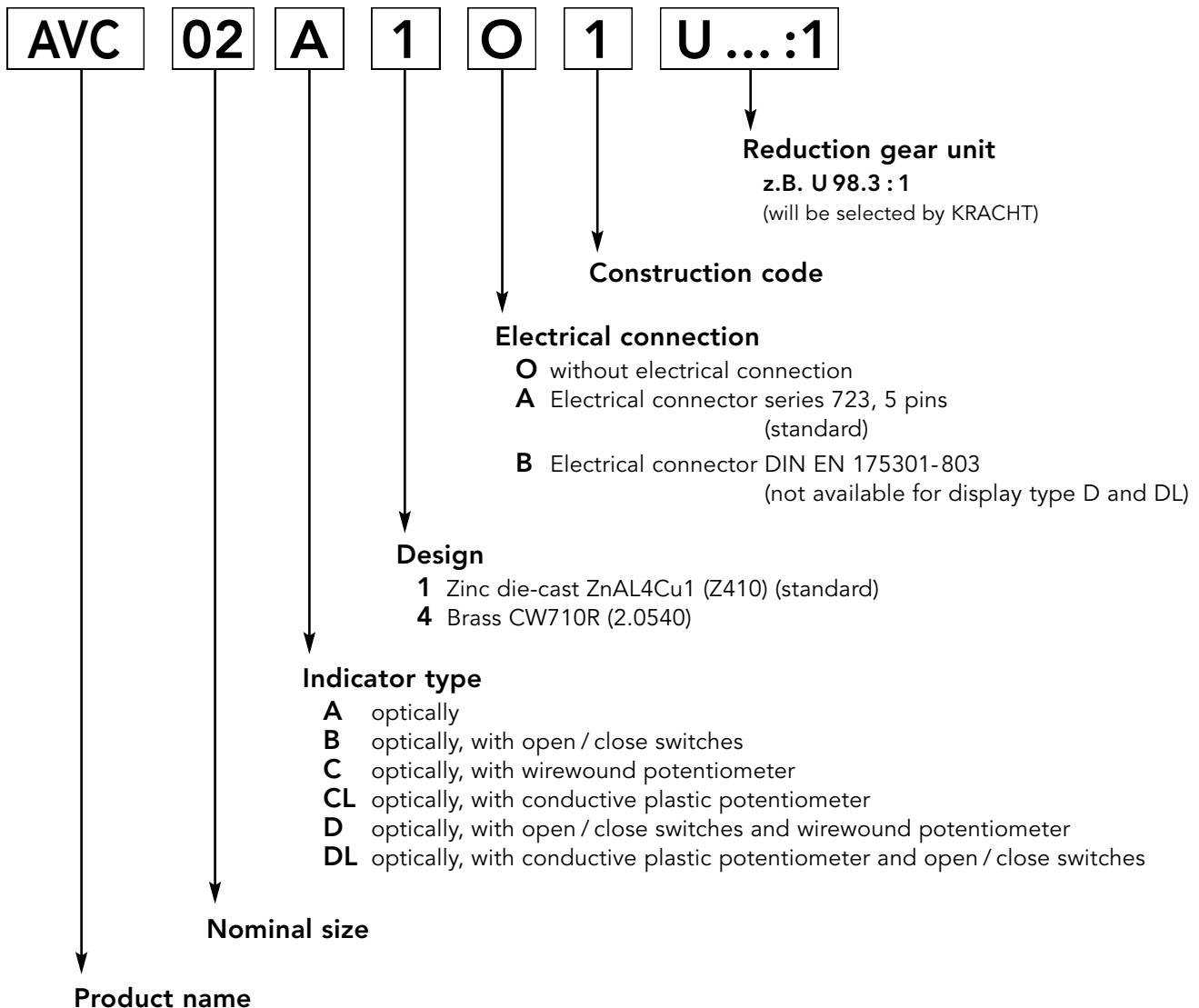

## Indicator AVC 02

### Electrical characteristics

#### Electric installation – Indicator type B

Miniature round connector serie 723

Contact plate

Contact arrangements, view to the solder-contacts

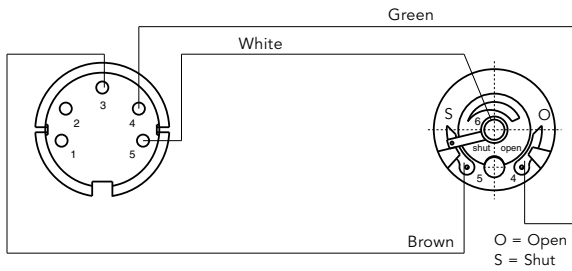

#### Electric installation – Indicator type C, CL

Miniature round connector serie 723

Potentiometer

Contact plate

Contact arrangements, view to the solder-contacts  
Open ca. 800 Ohm  
Shut ca. 220 Ohm

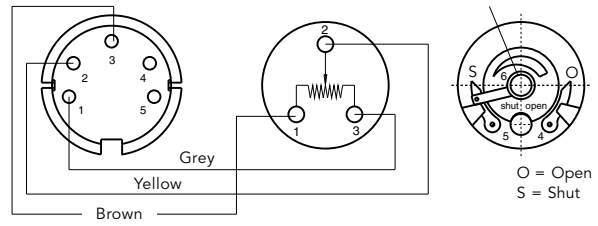

#### Electric installation – Indicator type D, DL

Miniature round connector serie 723

Potentiometer

Contact plate

Contact arrangements, view to the solder-contacts  
Open ca. 800 Ohm  
Shut ca. 220 Ohm

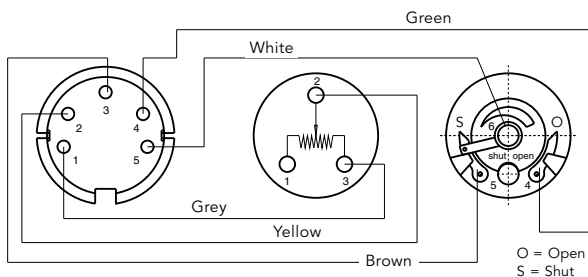

#### Technical data potentiometer

##### Electrical data

Nominal resistance R  
Resistance tolerance  
Linearity  
Max. wiper current in case of malfunction  
Power rating P  
Dielectric strength  
Insulating resistance  
Resistance resolution

wirewound potentiometer (C, D)

1 K  $\Omega$   
 $\pm 10\%$   
 $\pm 1.0\%$   
100 mA  
1 W/85 °C (195 °F)  
900 VAC/1 min  
10 G  $\Omega$  at 500 V DC  
0.37 %

conductive plastic potentiometer (CL, DL)

1 K  $\Omega$   
 $\pm 20\%$   
 $\pm 2\%$   
1 mA  
0.2 W to 55 °C (131 °F)  
500 V<sub>eff</sub>/1 min  
>1 G  $\Omega$  at 500 V DC

##### Ambience conditions

Operating temperature  
Climatic rating  
Degree of protection  
Vibration  
Shock

-55 °C ... +150 °C (-131 °F ... +302 °F)  
55/150/56  
IP 67  
10 g  
(30 ... 2000 Hz, 0,75 mm)  
50 g (half sine pulse, 7 ms)

## Indicator AVC 02

### Dimensions AVC 02.1 (Standard)

Indicator without angled connector (Indicator type A)

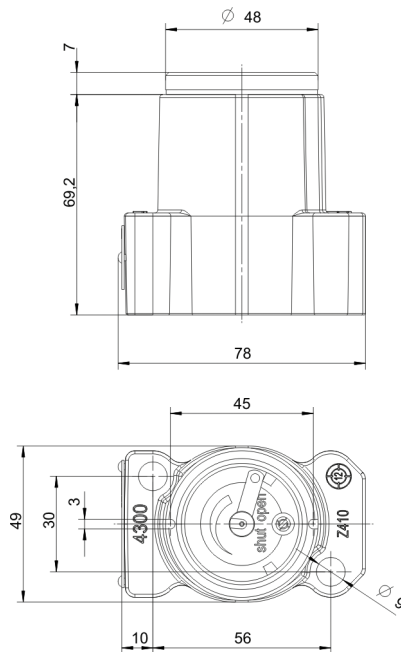

Weight: 0,7 kg

Indicator with angled connected (Indicator type B, C, CL, D und DL)

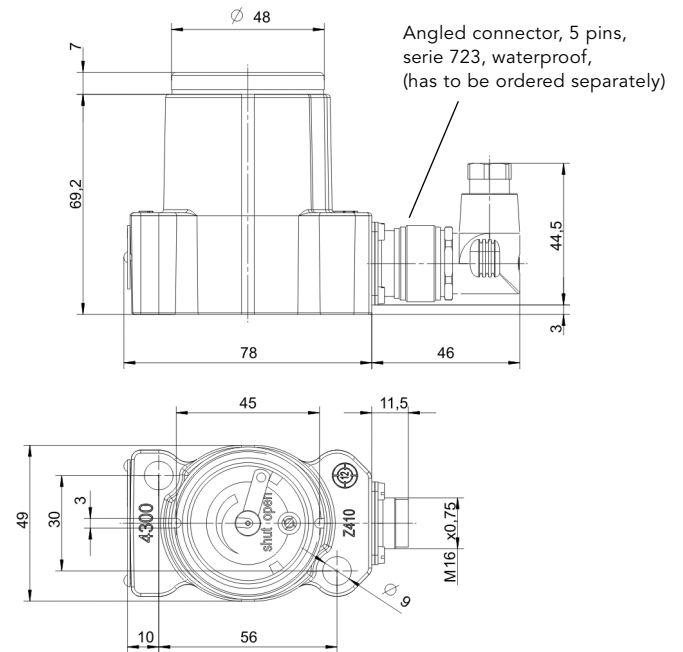

Weight: 0,75 kg

Angled connector, 5 pins,  
serie 723, waterproof,  
(has to be ordered separately)

### Dimensions AVC 02.4 (Brass)

Indicator without angled connector (Indicator type A)

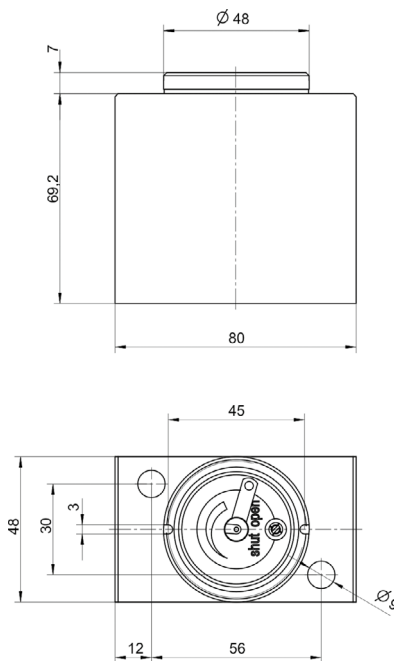

Weight: 1,6 kg

Indicator with angled connected (Indicator type B, C, CL, D und DL)

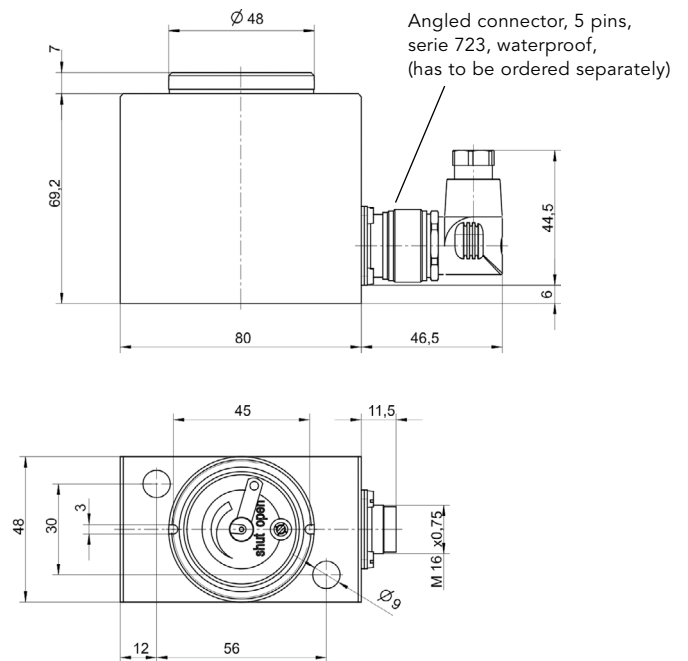

Weight: 1,65 kg

Angled connector, 5 pins,  
serie 723, waterproof,  
(has to be ordered separately)

## Gear Type Volume Counter VCM 02/04

### Function

The gear type flow meter can be used with all known hydraulic fluids, which have a minimum lubricity, are not aggressive concerning the used materials. The movement of the gears is transferred to the indicator by a permanent-magnetic coupling.

There is no connection between the indicator and the hydraulic circuit. The volume counter with connected indicator is suitable for installation in deck-boxes.

### General characteristics

Connection	Plate mounted
Weight	VCM 02.1... : 0,75 kg
	VCM 02.4... : 0,80 kg
	VCM 04.1... : 1,05 kg
	VCM 04.4... : 1,15 kg
Mounting position	optional
Dimensions	see page 8
Ambient temperature	$\vartheta_{m \min} = -20\text{ °C} (-4\text{ °F})$ $\vartheta_{m \max} = +60\text{ °C} (+140\text{ °F})$
Liquid temperature	$\vartheta_{m \min} = -20\text{ °C} (-4\text{ °F})$ $\vartheta_{m \max} = +80\text{ °C} (+176\text{ °F})$

### Hydraulic characteristics

Max. pressure	$p_{\max}$	= 200 bar
Max. pressure peak	$p$	= 240 bar
Max. flow rate	VCM 02 $Q$	= 4 l/min
	VCM 04 $Q$	= 7 l/min
Viscosity	$\nu_{\min}$	= 20 mm/s
	$\nu_{\max}$	= 380 mm/s (higher viscosities on request)
Fluids	Mineral oil acc. to DIN 51524/25 other fluids on request	

### Type key – Volume counter

#### Ordering example

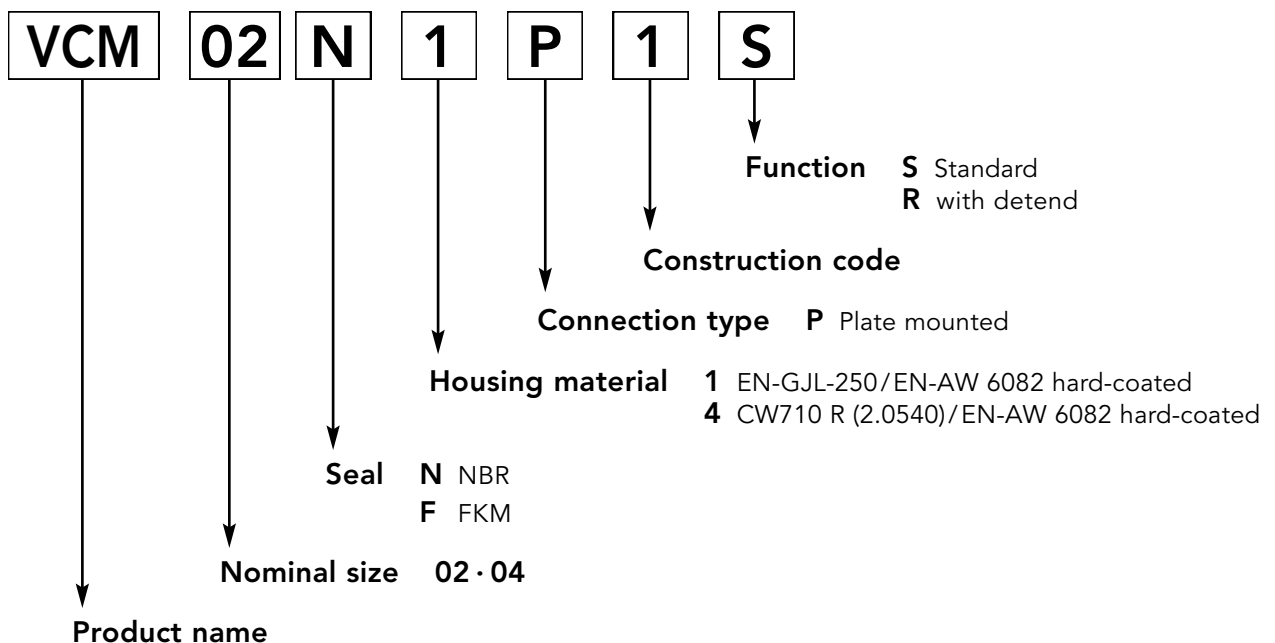

## Gear Type Volume Counter VCM 02/04

### Dimensions VCM 02...S (Standard)

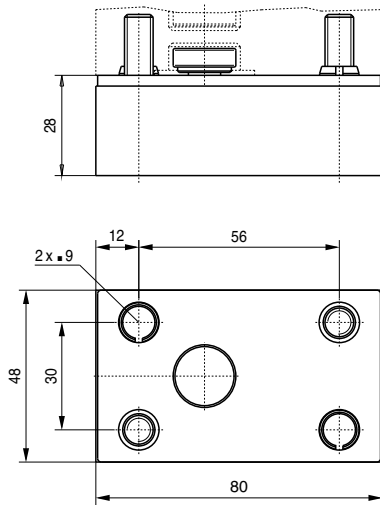

### Dimensions VCM 04...S (Standard)

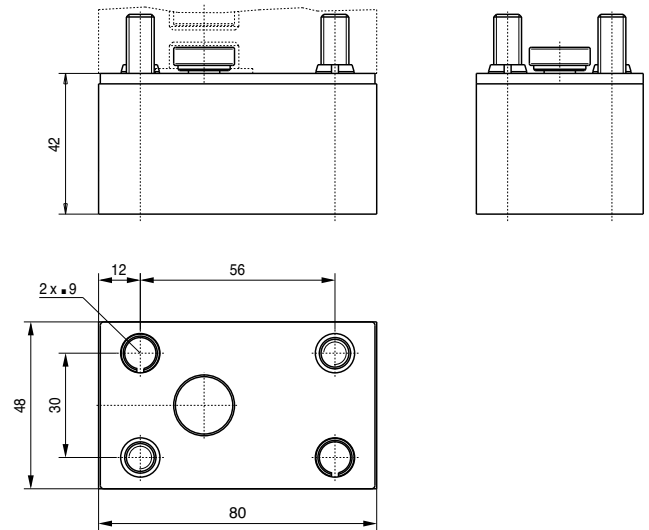

### Dimensions VCM 02...R (with detend)

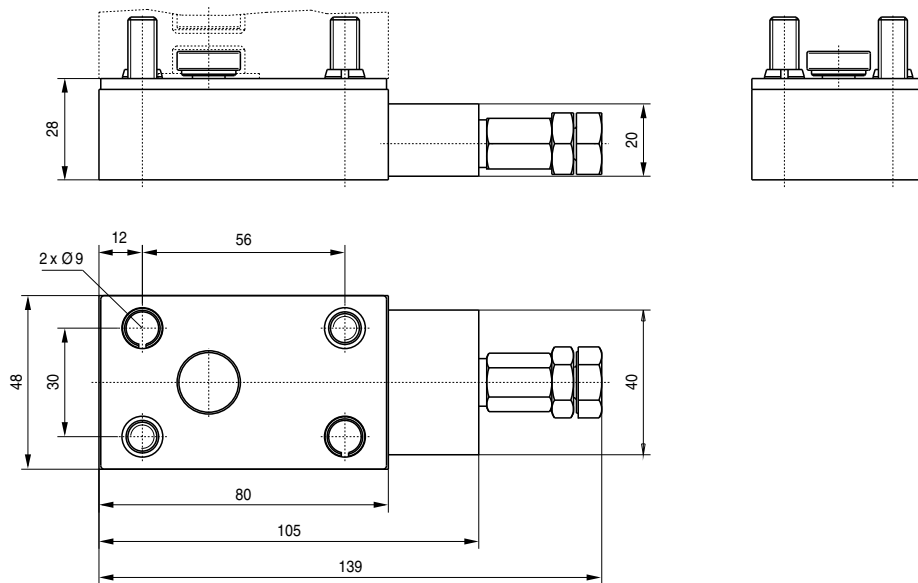

### Mounting surface VCM 02/04

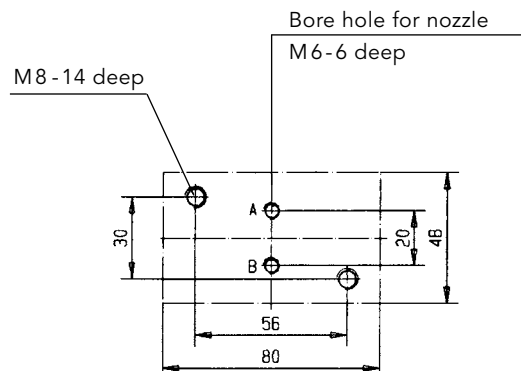



## Hydraulic Manifold HB 4

### Function 0311

- double pilot operated check valve for holding the actuator position
- two pressure relief valves for limiting the pressure caused by increased temperature
- throttle valve in port A for speed regulation of the actuator
- check valve for filling the piping to avoid wrong indications when temperature fluctuates

### Function 0324

- check valve in P for holding the actuator position when switching parallel actuators
- check valve in T to avoid indicator fluctuations due to pressure pulsation
- one temperature pressure relief valve for limiting the pressure caused by increased temperature
- throttle valve in port A for speed regulation of the actuator
- check valve for filling the piping to avoid wrong indications when temperature fluctuates

### General characteristics

Mounting surface	ISO 4401 / DIN 24340-A6
Nominal size	06
Design	Sandwich-seatvalve
Type of fixation	Plate mounted
Type of connection	Mounting plate
Dimensions	see page 10
Mounting position	optional
Flow direction	see schema page 9
Ambient temperature	$\vartheta_{\min} = -20\text{ °C} (-4\text{ °F})$ $\vartheta_{\max} = +60\text{ °C} (+140\text{ °F})$
Liquid temperature	$\vartheta_{m\ min} = -20\text{ °C} (-4\text{ °F})$ $\vartheta_{m\ max} = +80\text{ °C} (+176\text{ °F})$
Weight	HB 4 A 0311.. 5,2 kg HB 4 D 0311.. 6,2 kg HB 4 A 0324.. 3,9 kg HB 4 D 0324.. 4,7 kg

### Hydraulic characteristics

Operating pressure	$p_{\max} = 200\text{ bar}$
Pressure relief valve	$p_{\max\ DBV} = 240\text{ bar}$
Flow rate	6 l/min (10 l/min)
Viscosity	$v_{\min} = 20\text{ mm}^2/\text{s}$ $v_{\max} = 380\text{ mm}^2/\text{s}$
Fluids	Mineral oil acc. to DIN 51524/25 other fluids on request

## Hydraulic Manifold HB 4

### Type key – Hydraulic manifold

Ordering example

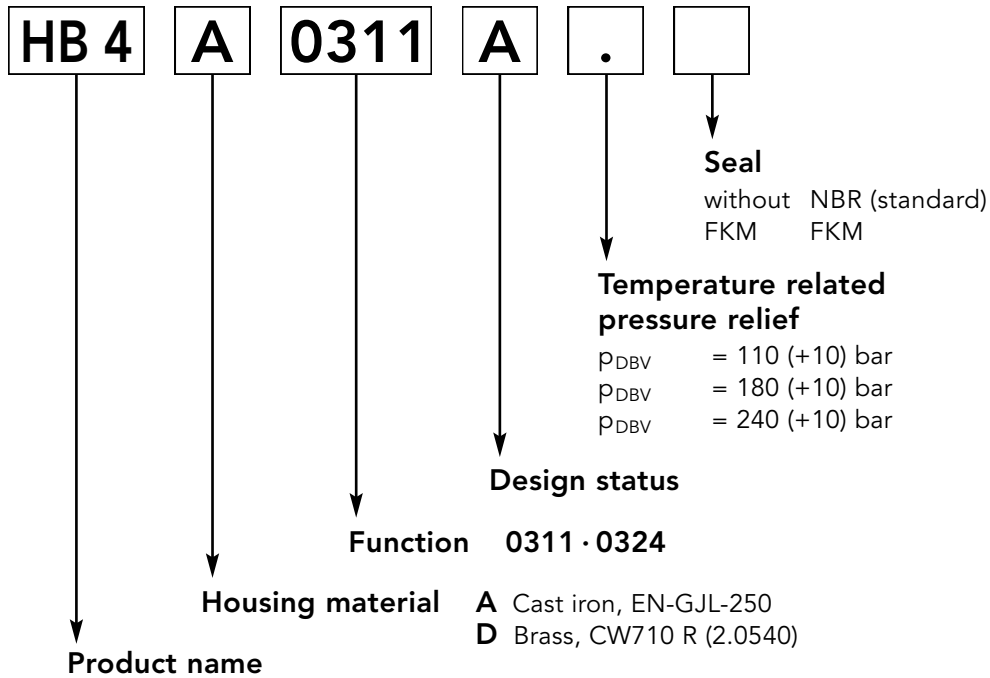

### Function

Scheme 0311

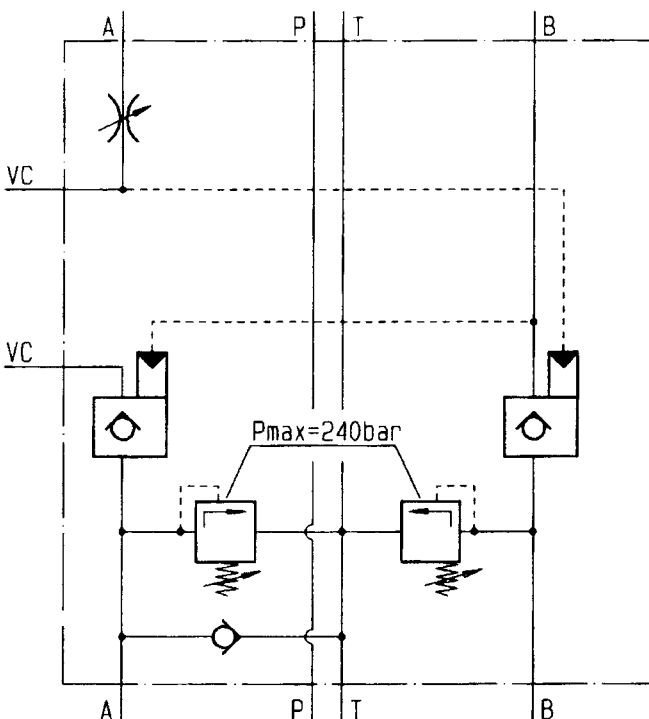

Scheme 0324

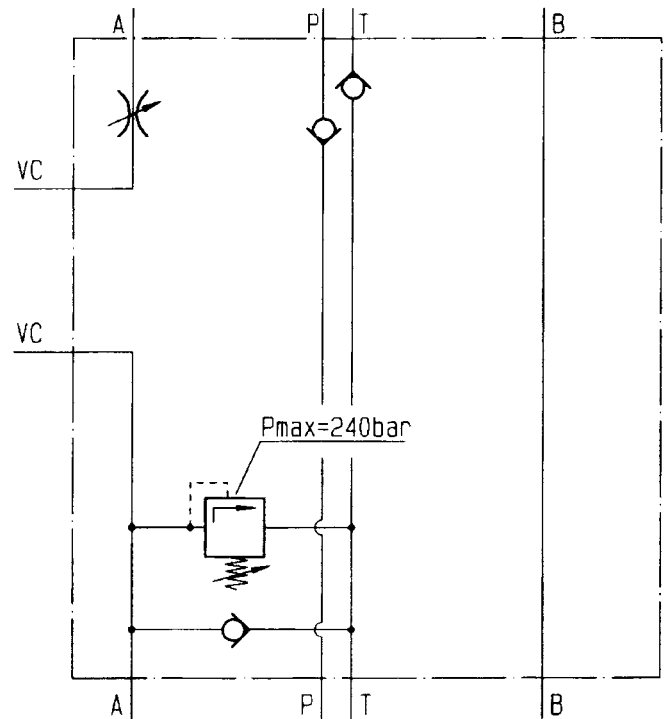

## Hydraulic Manifold HB 4

### Dimensions

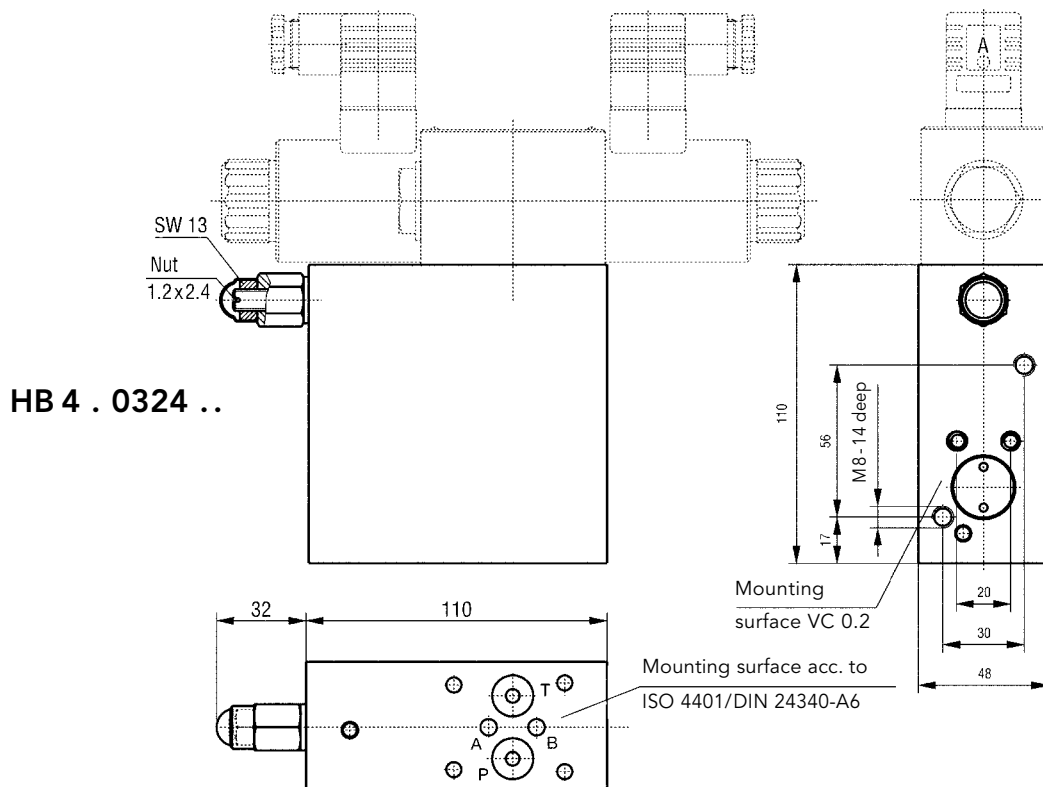
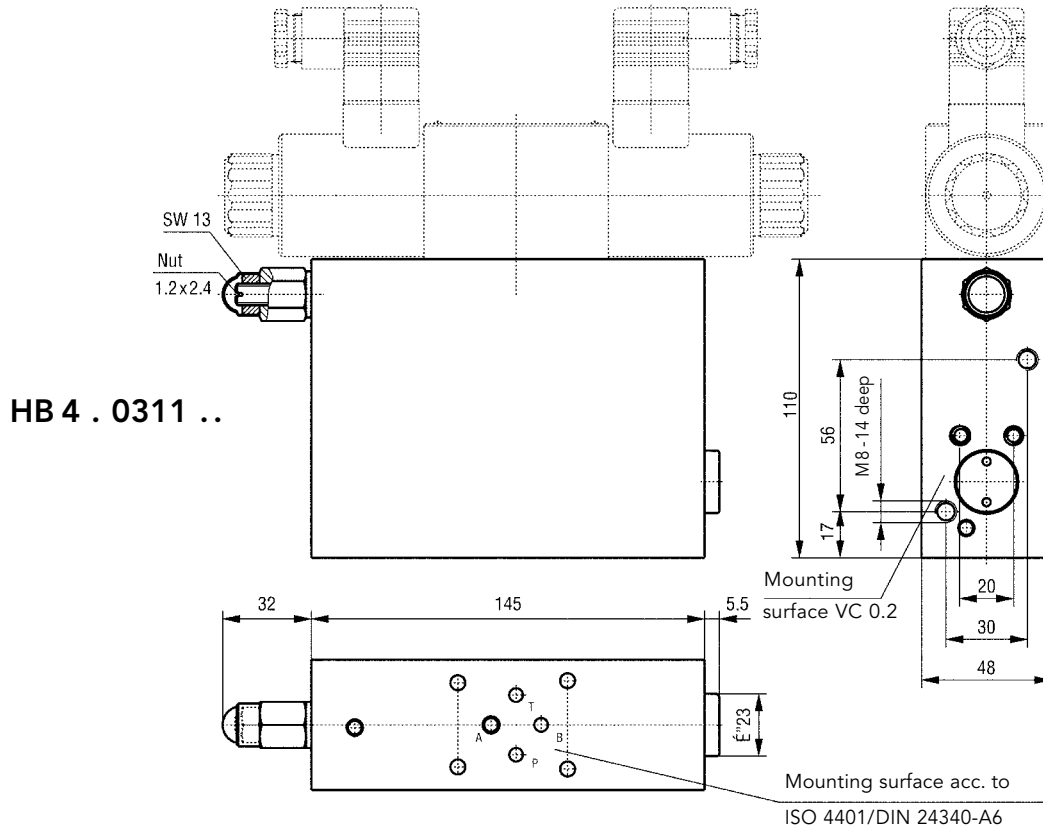

## Valve Position Measuring Instrument VCA 0.2 NB P2/171

### Dimensions

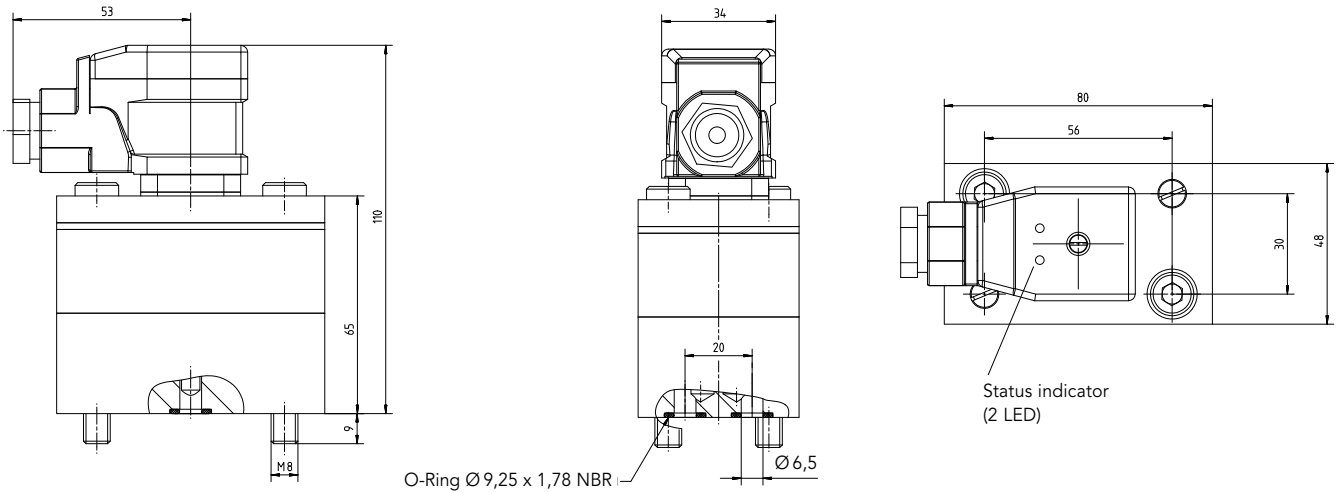

### Mounting surface

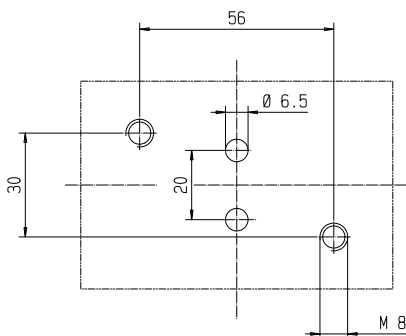

### Description

Now in the segment of the VOLUMEK Valve Position Indicators we offer beside the mechanical variation the electronic solution; the VOLUTRONIC<sup>®</sup> Valve Position Measuring Instrument VCA 0.2 NB P2/171. The electronic solution provides 2 incremental signals with 90° phase

shift and enables the recognition of the flow direction. The VOLUTRONIC<sup>®</sup> Valve Position Measuring Instrument VCA 0.2 can be used for a big range of actuator dimensions and Flow rate.

### Materials

Housing and cover	Aluminium AlMgSiF30
Gearing	Stainless steel 1.4462

### General characteristics

Bearing	Plastic plain bearings
Connection type	Plate mounting

### Hydraulic characteristics

Measuring range	0.25 ... 10 l/min
Repeat accuracy	< 0.3 %
max. operating pressure	160 bar
Liquid temperature	- 20 ... + 80 °C
Resolution	5000 pulse/liter

## Valve Position Measuring Instrument VCA 0.2 NB P2/171

### Electrical connection

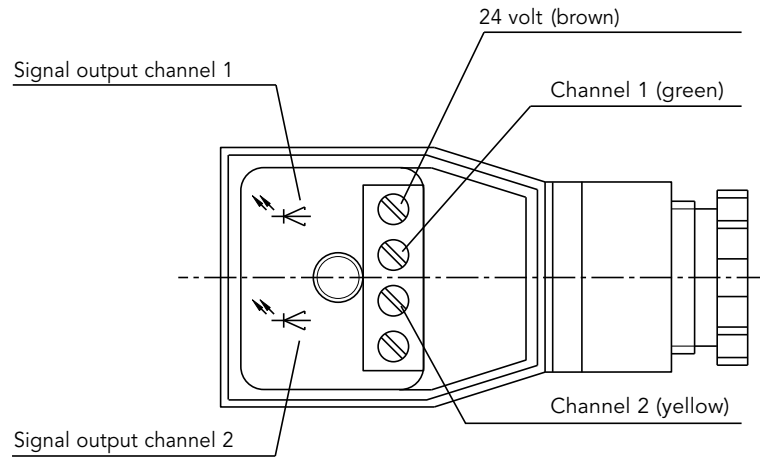

### Electrical characteristics

Number of measuring channels	2	Pulse offset between two channels	$90^\circ \pm 30^\circ$
Operating voltage	$U_B = 12 \dots 30 \text{ V DC}$ polarized	Power requirement	$P_{b \text{ max}} = 0.9 \text{ W}$
Pulse amplitude	$U_{\text{out}} \geq 0.8 U_{\text{op}}$	Output power/channel	$P_{a \text{ max}} = 0.3 \text{ W}$ short-circuit-proof
Pulse shape with symm. output signal	square wave pulse duty factor/channel $1:1 \pm 15\%$	Degree of protection	IP 65 DIN 40050
Signal output	PNP (NPN on request)	Status indicator (2 LED)	to blink = all right LED off = failure

### Signal characteristics

#### Channel I

- A rising edge
- B one pulse (corr. to flow rate of geom. tooth volume  $V_{gz}$ )
- C falling edge
- D ON phase
- E OFF phase
- F pulse duty factor  $1:1 \pm 15\%$

#### Channel II

- G channel offset
- H flow direction 1
- K reversal of flow direction
- J flow direction 2

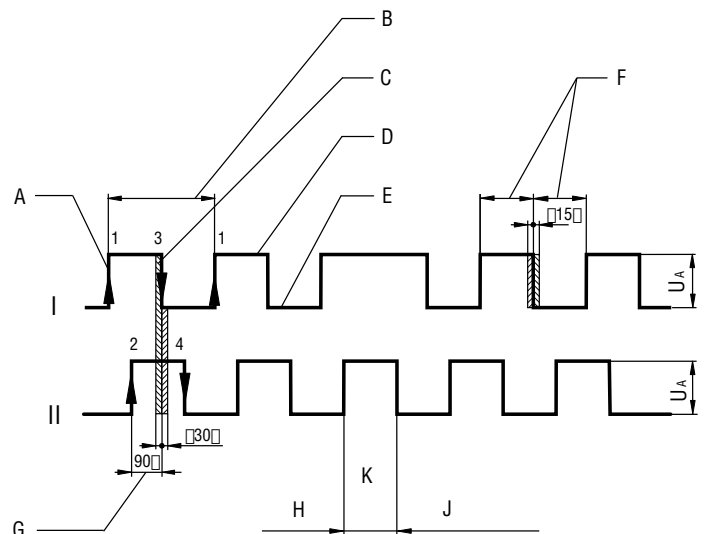

## Valve Position Measuring Instrument VC 0.2 P1 PX ATEX

### Explosion-proof version (ATEX)

The device fulfils the following protective classes:

- II 2 G EEx ia IIC T4
- II 2 D Ex iaD 21 T 125 °C
- II 2 GD C IIC T4 IP65 T 125 °C

### Dimensions

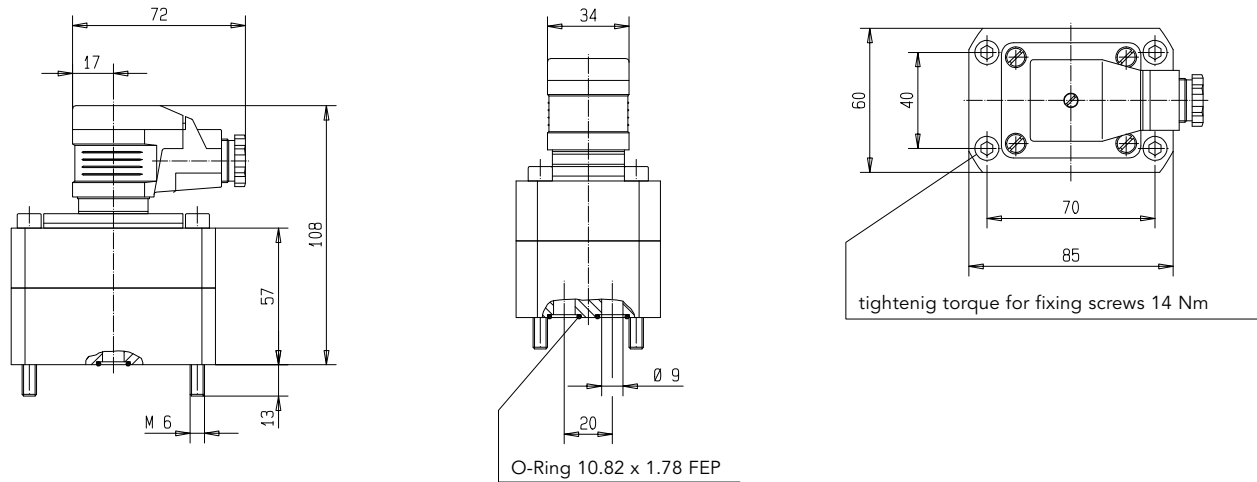

### Mounting surface

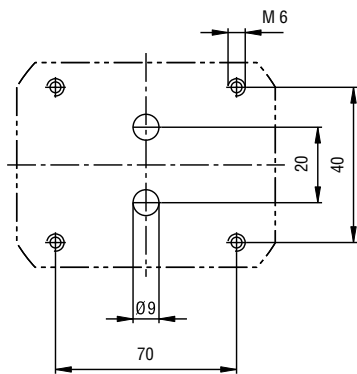

### Description

For the valve positions which must be used in intrinsically safe areas (example: Gas tankers) we offer the VOLUTRONIC<sup>®</sup> Valve Position Measuring Instrument VC 0.2 P1 PX ATEX. Also the explosion-safe execution

provides together with the switching amplifier K 130 two incremental signals with 90° phase shift and enables the recognition of the flow direction.

### Materials

Housing and cover	Spheroidal cast iron GGG 40
Gearing	Steel 1.7139

### General characteristics

Bearing	Ball bearings
Connection type	Plate mounting

### Hydraulic characteristics

Measuring range	0.16 ... 16 l/min
Repeat accuracy	< 0.1 %
Starting point	0.01 l/min
max. operating pressure	400 bar
Liquid temperature	- 30 ... + 80 °C
Resolution	4081.63 pulse/liter

## Valve Position Measuring Instrument VC 0.2 P1 PX ATEX

### Explosion-Proof Design (ATEX)

#### Function

- The explosion-protected execution passes of the VOLUTRONIC® Valve Position Measuring Instrument VC 0.2 P1 PX-ATEX (own-sure electric equipment) and the switch amplifier K 130 (accompanying electric equipment). To this construction counts the type of protection "intrinsic safety".
- The VOLUTRONIC® Valve Position Measuring Instrument is installed in the explosion-threatened area.
- The assembly of the switch amplifier K 130 occurs in the sure area.
- VOLUTRONIC® Valve Position Measuring Instrument and switch amplifier are connected electrically with each other. The switch amplifier evaluates the sensor signals of the Valve Position Measuring Instrument and converts them into square-wave signals.
- Without switch amplifier the VOLUTRONIC® Valve Position Measuring Instrument may be pursued not in the explosion-threatened area.
- Between Valve Position Measuring Instrument and switch amplifier cable lengths to 400 m are possible.
- In the switch amplifier are LED's to the control of management break/short circuit, canal-switch state and tension care.

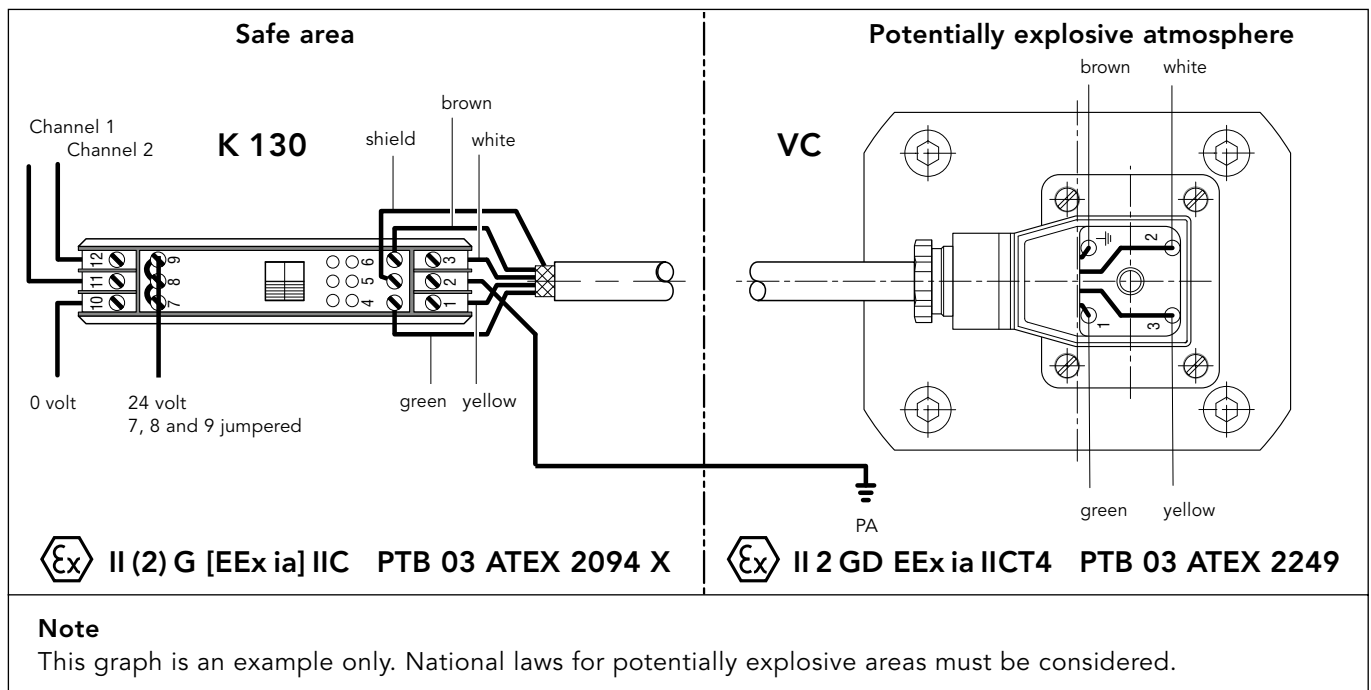

### Technical data of switching amplifier K-130/3-E-10

#### Power supply

Supply voltage cl. 7 (L+), cl. 10 (L-) DC 24 volt  $\pm$  20 %  
 Ripple content white Wss < 10 %

#### Outputs (non-intrinsically safe)

##### Characteristics cl. 9, 12, 8, 11

Electronics outputs electrically isolated via optoelectronic coupler  
 Short-circuit current approx. 25 mA  
 Signal level 1-signal 0.8 x supply voltage with  $R_L > 2 \text{ k ohm}$   
 Signal level 0-signal inhibited output, residual current < 10 uA

#### Ambience conditions

Minimum limiting temperature 248 K (-25 °C)  
 Maximum limiting temperature 333 K (+60 °C)

#### Mechanics

Dimensions 107.5 x 92 x 22 mm  
 Connection possibility can be snapped on a 35 mm mounting channel DIN 46277  
 Weight approx. 150 g

**Valve Position Measuring Instrument VC 0.2 P1 PX ATEX**

<b>Recording of the application datas for KRACHT Valve positions indicators components</b>		
Customer		
Quantity		
Fluid		
Viscosity		mm <sup>2</sup> /s
Flow rate		l/min
Actuator displacement		cm <sup>3</sup>
operating pressure		bar
Setting of temperature pressure relief valve		bar
Liquid temperature		°C
Environment temperature		°C
Distance between Volumec and Valve		m
Inner diameter of piping		mm
Needed output	indication	
	indication + open/close switches	
	indication + potentiometer	
	indication + open/close switches + potentiometer	
if potentiometer, max. wiper current		mA
zone, in case of hazardous area		
Function of directional control valve	4/3 spring centered	
	4/2 with detend	
	4/2 spring return	
closing time of the actuator		sec.
<b>Armatuur</b>	<b>type of armatur</b>	<b>name of producer</b>
	single acting actuator (spring return)	
	double acting actuator (Rack and pinion)	
	double acting actuator (Scotch yoke)	
	linear actuator (spring return)	



**Declaration for Apparatus without an own Potential Ignition Source in Conformity with the Explosion Safety Directive 94/9/EC (ATEX 95)**

**Kracht GmbH hereby declares that the switches and/or potentiometers in the Volumec indicating device**

are not

- a. safety, controlling and regulating devices,
- b. equipment,
- c. protective systems or
- d. components

in accordance with Directive 94/9/EC, Article 1 paragraphs 2 and 3

The switches and/or potentiometers are used potential-free as simple apparatus in intrinsically safe circuits, with a max. operating temperature of 60°C the supplied output  $P_i$  may not exceed a value of 1.2 Watt. The switches and/or potentiometers **are not marked** in accordance with the ATEX Directive.

An internal ignition risk assessment was carried out and an internal confidential test report PB62060405 drawn up on this.

The switches and/or potentiometers can be used as follows, taking account of the applicable installations rules for machinery, appliances and installations in potentially explosive areas, e.g. EN 60079-14:

- a) In Group II Zone 2 (Gas-Ex, Category 3G) Explosion Groups IIA, IIB and IIC
- b) In Group II Zone 1 (Gas-Ex, Category 2G) Explosion Groups IIA, IIB and IIC

The following harmonised standards/specifications were applied in the version that is valid on the date of signature:

- EN 1127-1 Explosive atmospheres, explosion protection, part 1: Fundamental principles and methods
- EN 50020 Electrical apparatus for potentially explosive atmospheres, part 7: Intrinsic safety

Important information:

- The maximum surface temperatures depend on the mounting situation and are the responsibility of the customer or the operator. In normal use the threshold values of temperature class T4 cannot be reached.
- All external materials consist of suitable low-sparking materials. However, the operator is responsible for checking the danger of ignition through sparking when the complete machine is operated. Light-metal parts must be mounted protected against external impact energy.
- The listed components are suitable for ambient temperatures of -20°C .. +60°C. Temperature class T4 is complied with.
- With an ambient temperature of 60°C the output  $P_i$  of the supply circuit may not exceed 1.2 Watt.
- Compliance with the information in the manufacturer's operating instructions is mandatory.

Werdohl, 8 May 2006

Place and date

  
Heiko Zahn, Managing Director

## I Gear Pumps

Low and high-pressure gear pumps for lubricating oil, hydraulic, process and test bench applications, fuel and metering systems.



## I Flow Measurement

Gear, turbine and screw type flow meters and electronics for volume and flow, metering and consumption in the chemical industry, hydraulic, process and test bench technology.



## I Hydraulics

Single and multistage high-pressure gear pumps, gear motors and valves for construction machinery, municipal vehicles, agricultural vehicles, special vehicles and truck bodies.



## I Valves

Cetop valves for all requirements stationary and mobile applications. Pressure, switching and stop valves with pipe connection for high flow rates. Special valves.



# KRACHT®

KRACHT GmbH · Gewerbestraße 20 · 58791 Werdohl, Germany  
 Phone +49 2392.935 0 · Fax +49 2392.935 209  
 E-Mail [info@kracht.eu](mailto:info@kracht.eu) · Web [www.kracht.eu](http://www.kracht.eu)