



Warner Linear H-TRACK

Electric Linear Actuator System

Warner Linear H-Track Actuators

MORE POWER IN LESS SPACE

The H-Track provides the performance of hydraulics without the expansive space requirements nor the prohibitive cost of full-sized hydraulic systems.

The H-Track is a robust electric actuator solution with a force up to 4800lbs (21350N) and travel speeds near 4 inches (100mm) per second. The H-Track family feature the smallest mounting envelope in their class with a patented valve and reservoir design that provides significant space savings compared to competitive models.

The completely sealed H-Track models are weather-proof, dust tight, corrosive resistant, and IP67 static (temporary submersion) and IP69K (high pressure wash-down) tested. The H-Track features three different hydraulic fluid options that allow the units to operate in temperatures as low as -40°F (-40°C) to as high as 180°F (82°C), making the H-Track an ideal option for use in demanding conditions.

With stroke lengths up to 16 inches (406mm), end switch options, and multiple configurations available, the H-Track is an exciting new addition to the actuator market.

Designed for use in extreme applications requiring high load capacity in a small footprint



VISIT US ON THE WEB AT
WWW.THOMSONLINEAR.COM/WARNERLINEAR

Table of Contents

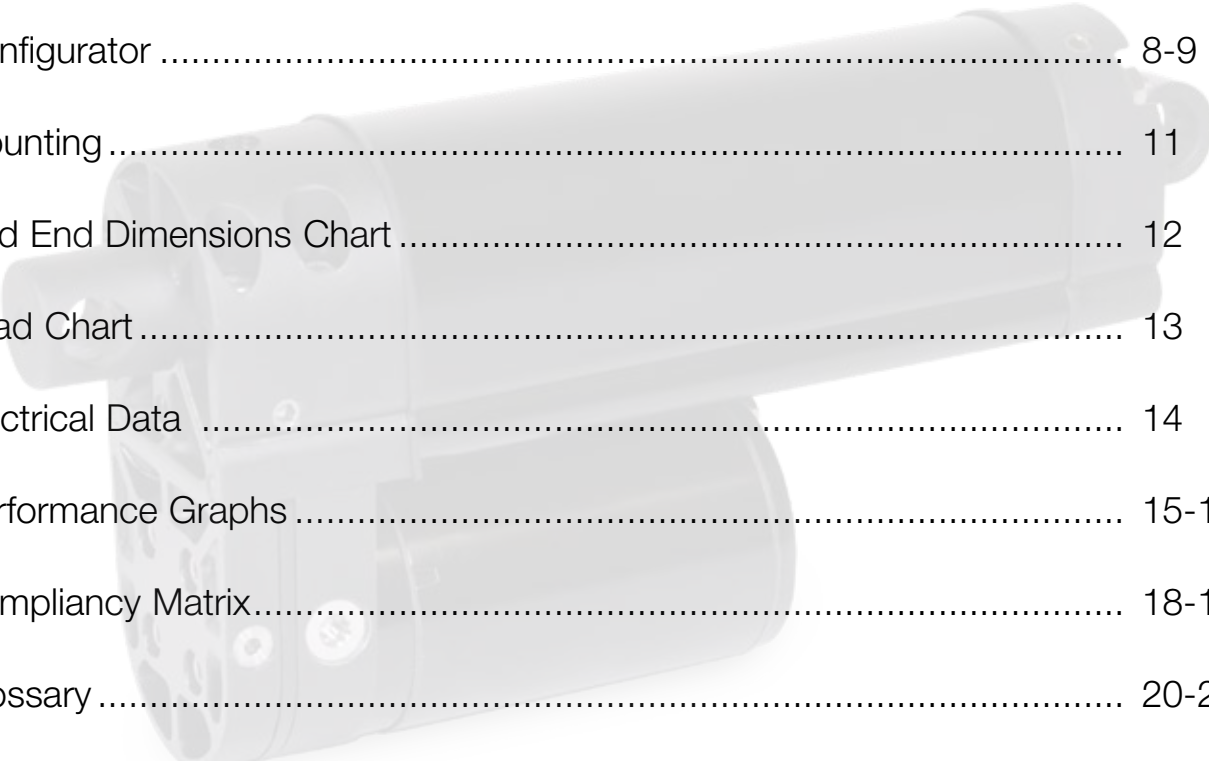

Applications.....	2
Features	3-4
Overview/Dimensions	5-6
Selection Guide	6-7
Configurator	8-9
Mounting	11
Rod End Dimensions Chart	12
Load Chart	13
Electrical Data	14
Performance Graphs	15-17
Compliance Matrix.....	18-19
Glossary	20-21
Application Data	22

H-Track Applications

The H-Track is a new electric actuator with self-contained hydraulic actuation to meet the growing demand for power dense actuators used in a variety of industrial applications including ag sprayer booms, snow plow blades, patient lifts and mower deck lifts.

DESIGNED TO WITHSTAND HIGH LOADS AND JARRING BOUNCES IN THE FIELD

With agricultural sprayers becoming larger, their boom lengths reaching 130ft in the U.S. and 177ft in Europe, the strain on the actuators have increased exponentially. The H-Track is an excellent option to meet these daunting requirements.

Actuators are used to fold the long sprayer booms from an extended position to a stowed position for transport. The folding and unfolding of the booms apply very high loads on the actuators. The strain on the units is dramatically increased when the sprayer is in motion and the bouncing of the booms put extreme loads on the actuator system.

These combined loads create tremendous impact force that can easily destroy most other electric actuators. The H-Track is designed to handle this type of extreme loading with ease.

H-TRACK MODELS ARE IDEAL FOR USE IN DEMANDING OUTDOOR APPLICATIONS

The outdoor environment creates very severe conditions for actuator applications. The fully-sealed H-Track family can easily meet the demands of the great outdoors.

Snow plows are a harsh application for actuators and routinely encounter damaging events that could quickly destroy most other linear actuators, such as striking a stationary concrete object at speed. The H-Track's unique valve and reservoir design gives it the ability to cushion these blows and continue operating without issue. And the optional ability to operate in temperatures of -40°F makes it a perfect fit for even the coldest climates.

Mower deck lifts are typically where electric actuators shine. However, with the increasing deck sizes and ground speeds being developed for faster mowing, the limits of traditional electric actuators are being exceeded. With its reliable load-holding capabilities, enhanced durability for higher transport speeds, and ability to withstand high-pressure wash-downs, the H-Track is a perfect choice for the next generation of larger and faster mowers.



H-Track Electric Linear Actuator System

Completely Self-Contained

The motor, pump and valves are contained in one mini **Power Pack** mounted directly to the **Integrated Cylinder/Tank**

The Power Pack

- Only two wires to connect
- Two gear size options in combination with multiple gear housing thickness allow for variable pressures and flow
- Flow direction controlled by the rotational direction of the attached motor
- Unique valve arrangement minimizes parts and solve volume/pressure differential problems
- Patent-pending split tanks shuttle valve with backpressure relief improves efficiencies
- Three-piece design allows for multiple arrangements beyond just the one attached actuator, such as accumulators, external cylinders, and stand-alone tanks
- Many motor options can be tailored to match just about any application offense

Compact gear pump and valves have many configurations to accommodate many different pressure and flow outputs

Multiple rod ends available. Threaded connections, spherical bearings

Integrated Cylinder and Tank

The cylinder, reservoir is utilized for an extremely compact solution that is consistent in proportion to stroke.

- The cylinder and reservoir is utilized for an extremely compact solution that is consistent in proportion to stroke
- Cover tube acts as a reservoir for the pump that improves the cooling of the media
- Tie rod construction
- Tank reservoir covers pressure cylinder volumetrically proportional to stroke length
- Manual override allows the rod to float for operating in emergency situations

Manual release

2 standard base end fitting options available.

H-Track Electric Linear Actuator System

Compact design

H-Track actuators can fit into applications with a pin-to-pin length as small as 4.8 inches (121.92mm) + stroke and still provide up to 4800lbs (21350N) of force.

Maintenance-Free

Units are lubricated for life during assembly requiring no adjustments or maintenance for the actuators after they leave the factory ensuring consistent performance for the life of the actuator. All actuators feature a one year limited warranty protection.

Superb Load Holding Power

Warner Linear H-Track actuators operate in both tension and compression. They will hold a load stationary without power in either direction. Static load holding capability will always exceed the dynamic load moving capability.

Energy Efficient

Electric control provides clean, smooth linear motion without hydraulic plumbing or other expensive componentry. The H-Track's power demands are significantly less than those of a full hydraulic system as the actuators require power only when in motion.

Overload Protection

Motors incorporate thermal switches in their windings to shut the actuator motor off in case of overheating or high overcurrent. Reset is automatic after the motor has cooled. A standard overload value detects if the load is excessive or reaches end of stroke.

Versatile

Various pump configurations create speeds that range from 0.2 inches (5mm) per second to nearly 4 inches (100mm) per second. Multiple rod ends allow for mounting flexibility. 250 and 560 Watt motor options that can use 12, 24, or 48VDC eases power supply connectivity constraints.

Other Advantages

- Simple installation and operation
- Safely absorbs impact shocks
- Resists drifting and locks during load reversals

FEATURES INCLUDE:

- Flexible bore and rod combinations allow for multiple mounting configurations
- Solid rods allow for increased resistance to buckling
- Actuator mounting length is shorter than any other electromechanical actuator on the market
- Immune to vibrational drifting and hydraulically self-locks
- Optional meter out circuits on one or both sides of the actuator ensures load run-away situations will not occur
- Fluid reservoir is vented and isolated from the atmosphere with a flexible lid allowing actuator and pump operation in any orientation without entraining or cavitation
- Minimum mounting clearance of 4.8 inches

H-Track Electric Linear Actuator System



Features

- **Hydraulic** drive delivers up to 4800 pounds (21350N) of force and travel speeds near 4 inches (100mm) per second.
- **The anodized aluminum alloy** housing resists corrosion and provides protection from dirt, dust, humidity and many corrosives. See Compliance Matrix on page 18-19.
- **Temperature operating range** of -20° F to +150° F (-26° C to +65° C).
Standard
-40° F to +130° F (-40° C to +54° C) and
0° F to +180° F (-18° C to +80° C) available.
- **Standard stroke lengths** of 2, 4, 6, 8, 10, 12, 14 and 16 inches (51, 102, 152, 203, 254, 305, 356, 406 millimeters)
- Consult factory for special or longer strokes
- **IP69K Dynamic
IP67 Static (Temporary Submersion)**
- **Rod does not require torsional restraint**

The H1, H2 and H3 are the base models in the H-Track family. They incorporate a patented fluid power design which provides high load capability for extreme duty use, a more compact pin to pin than other actuators of the same load capability, excellent ingress protection and corrosion resistance.

The H-Track uses an external gear pump connected to a reservoir and actuator yielding the most impact resistant actuator offered by Warner Linear. The H-Track pump is burnished, cleaned, flushed and vacuum filled with degassed hydraulic fluid. The system is completely sealed with no hoses to leak. This ensures you receive contaminant-free and maintenance-free product for the life of the actuator.

Specifications	
Load Capacity	Up to 4800 lbs. (21350N), see page 13
Speed	.2 in (5mm) to near 4 in. (100mm) /sec
Input Voltage	12, 24 or 48 volt DC for all models
Static Load Capacity	5000 lbs. (22241N) for all models in compression
Stroke Length	2, 4, 6, 8, 10,12, 14 and 16 in. (51, 102, 152, 203, 254, 305, 356, 406 mm) for all models
Clevis Ends	STD .625 in. (15.9mm) diameter
Duty Cycle	25% for all models
Operation Temperature Range	-20° F to +150° F (-26° C to + 65° C) for all models 40° F to +130° F (-40° C to +54° C) and 0° F to +180° F (-18° C to +80° C) available
Environment	IP65 Dynamic, IP69K and IP67 Static

H-Track Electric Linear Actuator System

Selection Guide

How To Select

The minimum data required to select a unit is:

1. Working Load
2. Stroke
3. Operating Voltage
4. Operating Orientation

Step 1 – Working Load

The working load should be the amount of force required from the actuator to push or pull the load in the mechanism. Ensure a proper mechanical analysis has been completed to identify the correct force requirements. It is recommended you apply 1.2 safety-factor to your force requirement to identify the working load.

Example (Figure 1): Through analysis you find the known weight on the lever arm results in 1500lb force requirement from the H-Track actuator. The working load= $1.2 \times 1500 = 1800\text{LB}$



Figure 1

Step 2 – Stroke

This is the amount of travel from full retract to full extend that can be expected from the actuator. In Figure 2, the lever arm is to move 5.5" from point "A" to point "B". As a rule of thumb add a small amount of extra travel to determine stroke so that the actuator does not bottom out internally. Although it is safe to bottom out the actuator, it is best practice to avoid doing so when possible.

Example (Figure 2): 5.5" (140mm) of travel required to move the load from point A to point B. Select an H-Track with 6" of stroke.

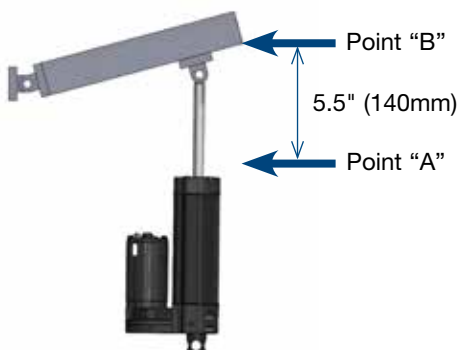

Figure 2

Step 3 – Operating Voltage

There are three cataloged options for the operating voltage. Typically the H-Track actuator is used on a mobile device with battery power. 12VDC, 24VDC and/or 48VDC are typical. Consult the factory for other available voltages. Be sure to size the wires accordingly. The 250Watt motor should have 10AWG to 12AWG supply wire size and the 560Watt motor 8AWG to 10AWG wire size.

Example: The application is a UTV with a 12VDC battery with 440 cold cranking amps and charged by an alternator. There are 10AWG wires available to power the actuator through a switching system that is capable of 60AMP's continuous current draw.

Step 4 – Operating Orientation

It is important to know if the load is compression, tension or both. See page 8 (Step 2) for application considerations. It is also important to know the effect from gravity. When moving the load in the same direction as acceleration from gravity, the load can over accelerate causing a chatter effect. In these cases a meter-out valve must be specified. Although the H-Track actuator in most cases can be operated in any orientation, consult factory for assistance with perfectly vertical rod-down orientation.

Example (Figure 3): Gravity will cause the load to accelerate compressing the actuator in the direction shown by the arrow. This is a rod-up condition. It requires a "meter out compression" valve to control the load safely.



Figure 3

H-Track Electric Linear Actuator System

Selection Guide

Building A Model Code

Using the previous example for defining the minimum data required to select an actuator we have the following information:

- 1800LB Working Load
- 6" Stroke
- 12VDC Operating Voltage
- Compression-Rod-Up Operating Orientation

Step 1:

Look up the working load in the Load Selection Charts provided on page 13. **Example:** _____

We find an actuator that is able to move 2000lbs during extend. We are not too concerned with the retracting load because the actuator is not required to pull in this application. We find a Bore Code of "H2", Pump Code "A2", Operating code "12" and a Motor Code of "1" (see Load Chart on page 13). "H2" also indicates we must have a .63" diameter. The Rod Code is "2" for that diameter rod. Looking at the H-Track configurator we have the start of a model code:

H2_-12-_A22-_-__

Step 2:

We are able to define the stroke needs to be 6". Looking at the H-Track configurator our model code now becomes:

H2_-12-_A22-_-06

Step 3:

The load is compression rod-up. With that information select a Metering code of "C".

▲NOTE If you are not sure of your load/rod orientation it is safest to select "B" for both to avoid an unsafe condition.

Our model code now becomes:

H2C_-12-_A22-_-06

Load Chart

Motor Code "1" 250 Watt Motor Performance

Below provides a selection as per this example

EXTENDING		RETRACTING	EXTENDING		
Max Load (lbs)	Max Load	Bore Code	Pump Code	No Load Speed	Max Load Speed (in/s)
500	375	H1	B4	3.5	1
750	563	H1	A4	2	0.6
1000	750	H1	B1	1.75	0.5
1250	992	H2	B3	1.4	0.4
1500	1125	H3	B3	1.2	0.35
1750	1313	H3	B2	1	0.29
2000	1587	H2	A2	0.65	0.19
2250	1688	H3	B1	0.8	0.23
2500	1983	H2	A1	0.5	0.15
3200	2400	H3	A1	0.45	0.13

Step 4:

12VDC is what is available on the mechanism we are applying the H-Track actuator to.

Our model code now becomes:

H2C_-12-1A22-_-06

Step 5:

Mounting in our example is ideal for the H-Track. Standard rod eye and base eye clevis style mounting are sufficient.

Finally the model code is complete:

H2C_-12-1A22-A-06

H-Track Configurator

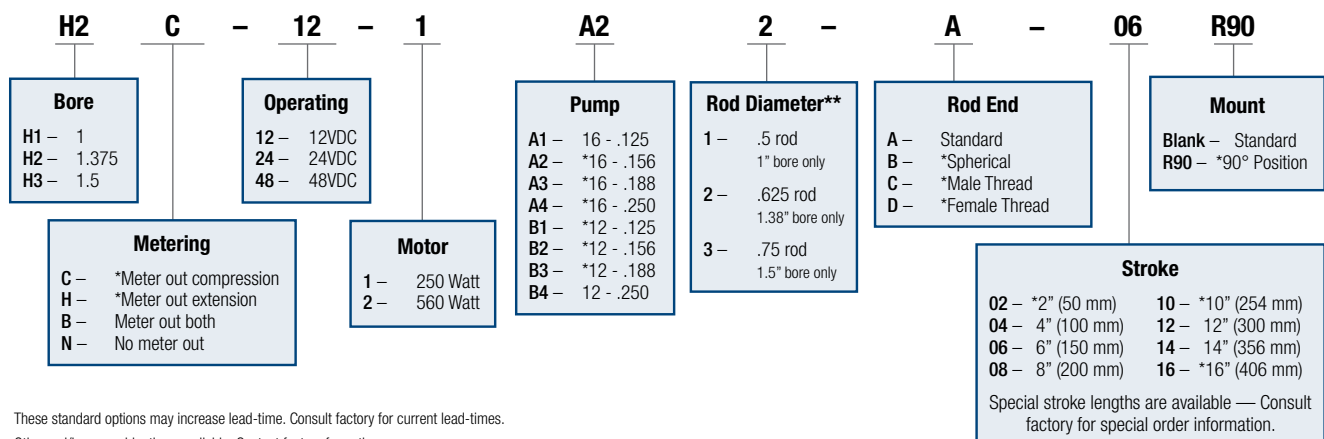

* These standard options may increase lead-time. Consult factory for current lead-times.

** Other rod/bore combinations available. Contact factory for options.

H-Track Electric Linear Actuator System

Product Configurator Overview

1 Step 1: Bore

Three bore sizes allowing for variable forces and travel speeds. See load charts (Step 4) to determine the bore code.

2 Meter Out Circuits

It is critical to understand the loading conditions for "Metering" model code designators to select the correct configuration. Improper selection can cause chattering. Chattering is when the gravity accelerates the load faster than the motor can move it. It causes the load to slip and stick. It is damaging to the components connected to the actuator, however the actuator has protection to prevent damaging itself.

▲ NOTE If you are not sure of the metering code you must select, you may contact Warner Linear Engineering for assistance or select "B" for both. Selecting both will increase your minimum current draw, however, you will prevent chattering regardless of the load conditions.

Meter Out Compression: In this case the load is positioned in such a way that gravity will accelerate the load when the rod is retracting, pushing the rod back into the actuator. Select metering code "C".

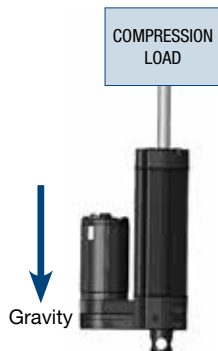

Figure 4

Meter Out Tension: In this case the load is positioned in such a way that gravity will accelerate the load when the rod is extending, pulling the rod out of the actuator. Select metering code "H".



Figure 5

H-Track Configurator

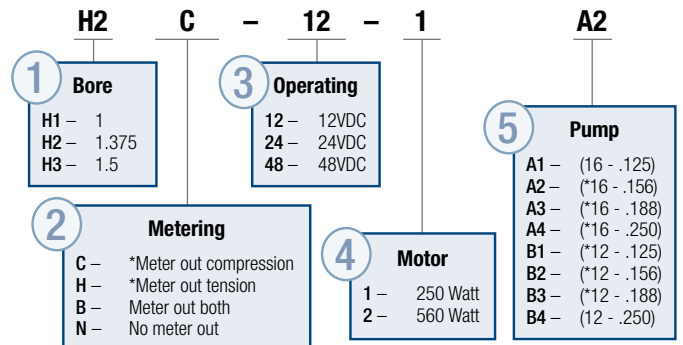

* These standard options may increase lead-time. Consult factory for current lead-times.
** Other rod/bore combinations available at a premium, contact factory for options.

Meter Out Both: In this case the load is positioned in such a way that gravity will accelerate the load when the rod is both extending, pushing the rod into the actuator and retracting, pulling the rod out of the actuator. Select metering code "B".

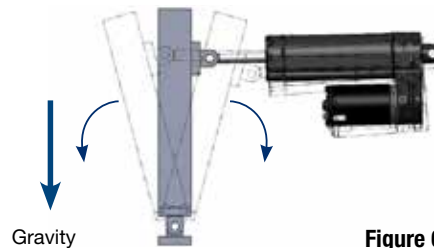

Figure 6

No Meter Out: In this case the load is unaffected by acceleration of gravity. There is no need to control the load because it is controlled by an external means. Select metering code "N".



Figure 7

3 Power Supply:

Ensure the power supply is capable of delivering full rated voltage and current for your selected configuration actuator for the length of required run-time. Operating voltage, see page 14 for electrical information.

Power Supply Chart			
Operating Code	Motor Code	Maximum Current Requirement	Nominal Operating Voltage
12	1	40 AMPS	12VDC
12	2	80 AMPS	12VDC
24	1	25 AMPS	24VDC
24	2	50 AMPS	24VDC
48	1	15 AMPS	48VDC
48	2	30 AMPS	48VDC

H-Track Electric Linear Actuator System

Product Configurator Overview

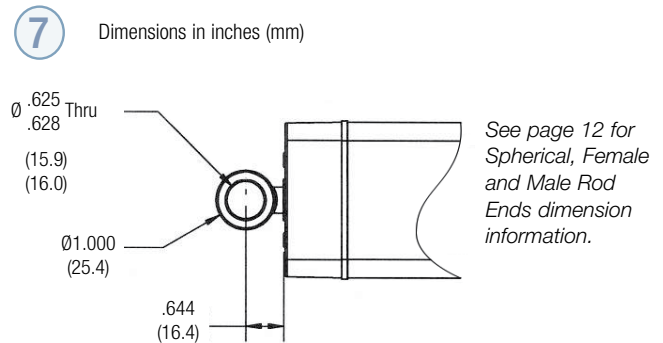
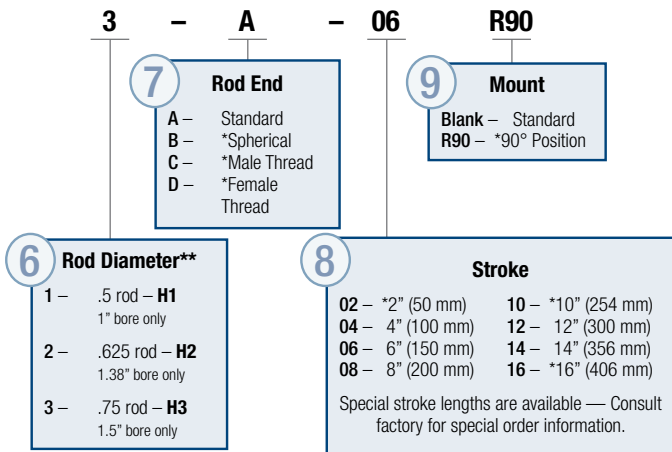

4 **Load Chart** – For example, see Building a Model Code on page 7
Motor Code "1" 250 Watt Motor Performance

EXTENDING		RETRACTING		EXTENDING		RETRACTING	
Max Load	Max Load	Bore Code	Pump Code	No Load Speed	Max Load Speed	No Load Speed	Max Load Speed
500	375	H1	B4	3.5	1	4.38	1.25
750	563	H1	A4	2	0.6	2.50	0.75
1000	750	H1	B1	1.75	0.5	2.19	0.63
1250	992	H2	B3	1.4	0.4	1.69	0.48
1500	1125	H3	B3	1.2	0.35	1.50	0.44
1750	1313	H3	B2	1	0.29	1.25	0.36
2000	1587	H2	A2	0.65	0.19	0.78	0.23
2250	1688	H3	B1	0.8	0.23	1.00	0.29
2500	1983	H2	A1	0.5	0.15	0.60	0.18
3200	2400	H3	A1	0.45	0.13	0.56	0.16

Load Chart
Motor Code "2" 560 Watt Motor Performance

EXTENDING		RETRACTING		EXTENDING		RETRACTING	
Max Load	Max Load	Bore Code	Pump Code	No Load Speed	Max Load Speed	No Load Speed	Max Load Speed
750	563	H1	B4	3.5	1	4.38	1.25
1125	844	H1	A4	2	0.6	2.50	0.75
1500	1125	H1	B1	1.75	0.5	2.19	0.63
1875	1488	H2	B3	1.4	0.4	1.69	0.48
2250	1688	H3	B3	1.2	0.35	1.50	0.44
2625	1969	H3	B2	1	0.29	1.25	0.36
3000	2380	H2	A2	0.65	0.19	0.78	0.23
3375	2531	H3	B1	0.8	0.23	1.00	0.29
3750	2975	H2	A1	0.5	0.15	0.60	0.18
4800	3600	H3	A1	0.45	0.13	0.56	0.16

5 **Pump Code is from Load Chart**

16 = Gear Tooth .125 = Thickness
 Three Housing Sizes (Thicknesses) allowing for variable pressures and volumes. See load charts (Step 4) to determine the pump code.

6 **Rod/Bore Specials**

Rod diameter relates to housing/cylinder. The rod diameter is dependent upon the selected bore size. If your application requires a different diameter than the one predetermined, please contact the factory for options.

8 **Rod Diameter with "A" Standard Rod End**

Stroke

This is the amount of travel from full retract to full extend that can be expected from the actuator. In Figure 2, the lever arm is to move 5.5" (140mm) from point "A" to point "B". As a rule of thumb add a small amount of extra travel to determine stroke so that the actuator does not bottom out internally. Although it is safe to bottom out the actuator, it is best practice to avoid doing so when possible.

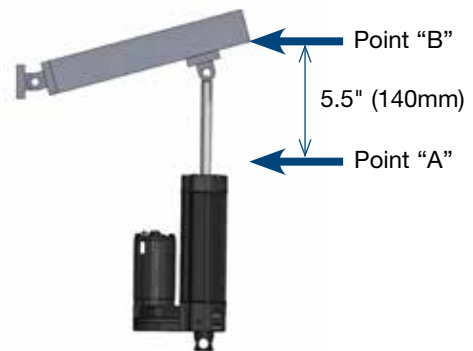
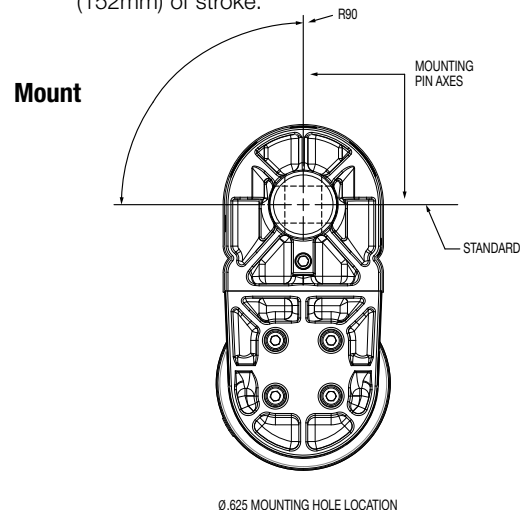

Figure 8

9 **Example (Figure 9):** 5.5" (140mm) of travel required to move the load from point A to point B. Select an H-Track with 6" (152mm) of stroke.



H-Track Electric Linear Actuator System

Dimensions

Bore/Rod Combo	Rod End "A"						Rod End "B"						Rod End "C"						Rod End "D"					
	H1		H2		H3		H1		H2		H3		H1		H2		H3		H1		H2		H3	
	"pp" INCH	"pp" MM	"pp" INCH	"pp" MM	"pp" INCH	"pp" MM	"pp" INCH	"pp" MM	"pp" INCH	"pp" MM	"pp" INCH	"pp" MM	"pp" INCH	"pp" MM	"pp" INCH	"pp" MM	"pp" INCH	"pp" MM	"pp" INCH	"pp" MM	"pp" INCH	"pp" MM	"pp" INCH	"pp" MM
2" (02) 50MM	6.8	173	6.8	173	6.8	173	7.5	190	7.4	191	7.7	196	7.1	181	7.3	186	7.5	191	6.2	157	6.2	157	6.2	157
4" (04) 100MM	8.8	224	8.8	224	8.8	224	9.5	241	9.5	242	9.7	247	9.1	232	9.3	237	9.5	242	8.2	208	8.2	208	8.2	208
6" (06) 150MM	10.8	274	10.8	274	10.8	274	11.5	292	11.5	293	11.7	298	11.1	283	11.3	288	11.5	292	10.2	259	10.2	259	10.2	259
8" (08) 200MM	12.8	325	12.8	325	12.8	325	13.5	342	13.5	344	13.7	349	13.1	334	13.3	338	13.5	343	12.2	310	12.2	310	12.2	310
10" (10) 254MM	14.8	376	14.8	376	14.8	376	15.5	393	15.5	395	15.7	400	15.1	385	15.3	389	15.5	394	14.2	361	14.2	361	14.2	361
12" (12) 300MM	16.8	427	16.8	427	16.8	427	17.5	444	17.5	445	17.7	450	17.1	435	17.3	440	17.5	445	16.2	411	16.2	411	16.2	411
14" (14) 350MM	18.8	478	18.8	478	18.8	478	19.5	495	19.5	496	19.7	501	19.1	486	19.3	491	19.5	496	18.2	462	18.2	462	18.2	462
16" (16) 400MM	20.8	528	20.8	528	20.8	528	21.5	546	21.5	547	21.7	552	21.1	537	21.3	542	21.5	546	20.2	513	20.2	513	20.2	513

"PP" = Pin to Pin Length. All stroke dimensions are in inches, millimeter strokes are rounded.

H-Track Dimensions

with "A" Standard Rod End shown

Dimensions in inches [mm]

See page 12 for dimensions for Rod End "B" Spherical, "C" Male Thread & "D" Female Thread

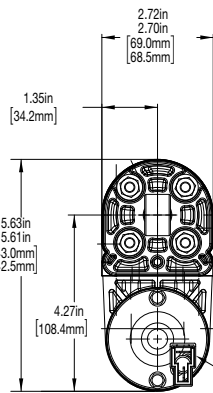

10" Lead wire length connect (-) to gray wire & (+) to black wire to retract the actuator. Reverse polarity to change direction of stroke. 240 Watt Motor (02.50) supplied with Packard 56 male std. connector. 560 Watt Motor (03.00) supplied with ring terminals.

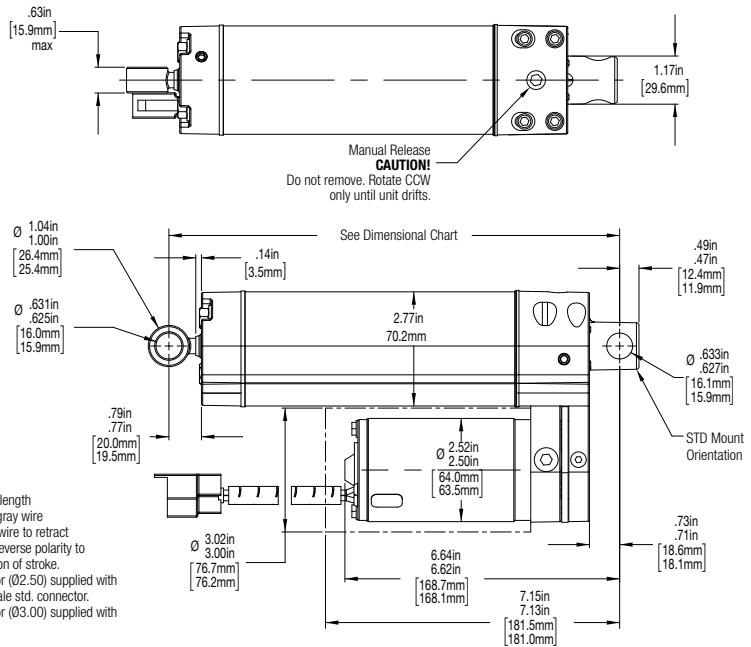

Dimensions are for installation only. Tolerances shown may not reflect component manufacturing tolerances.

Stroke Selection

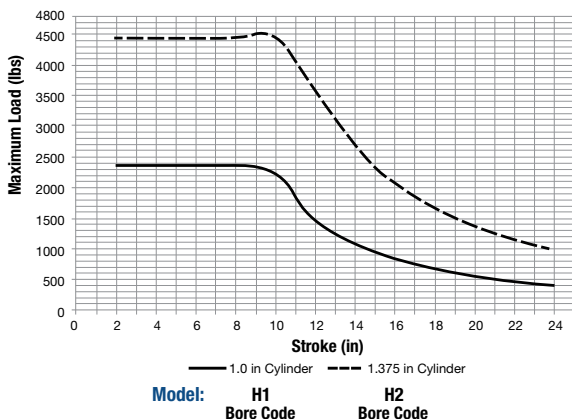

How to Use the Stroke Selection Chart

Avoid the potential for a piston rod to buckle under load.

- Step 1** Find your stroke length in the chart.
- Step 2** Draw a straight vertical line perpendicular from your stroke length (found in step 1) until it crosses all three of the graphed lines.
- Step 3** Find your maximum load in the chart.
- Step 4** Draw a straight horizontal line from your load (found in step 3) until you cross the first line drawn in step 2.
- Step 5** You can use any of the cylinder bore sizes in which the graphed lines are to the left of the line you drew in step 2 and above the line you drew in step 4.

H-Track Electric Linear Actuator System

General Mounting Information

Warner Linear actuators are quickly and easily mounted by slipping pins through the holes at each end of the unit and into the brackets on the machine frame and load to be moved.

Use of solid pins provide maximum holding capability with a retaining ring or cotter pin on each end to prevent pin from falling out (it is best to avoid roll pins and spring pins).

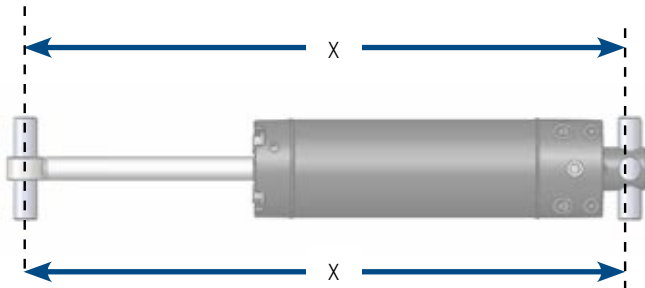

Mounting pins must be parallel to each other as shown above. Pins which are not parallel can cause excess vibration or actuator binding.

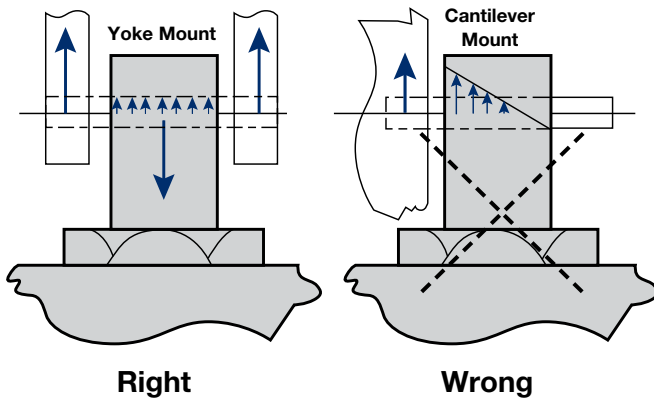

Ensure that mounting pins are supported at both ends. Cantilevered mounting is unacceptable. Failure to provide proper support will shorten unit life.



Scan to watch!

Proper Steps and Best Practices for Mounting of Warner Linear Actuators Video

<https://p.widencdn.net/k3etry>

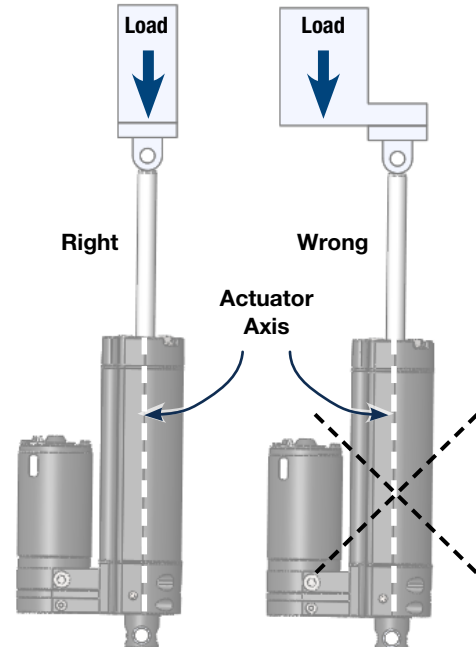

Loads should act along the axis of the actuator. Off-center loads may cause binding and lead to premature unit failure.



Do not attempt to mount H-Track actuators by the cover tube. The tube is not designed to support the forces required for tube mounting.

H-Track Electric Linear Actuator System

Dimension and Rod End Data

Additional H-Track Rod Ends Available Contact factory for options.

Dimensions in inches (mm)

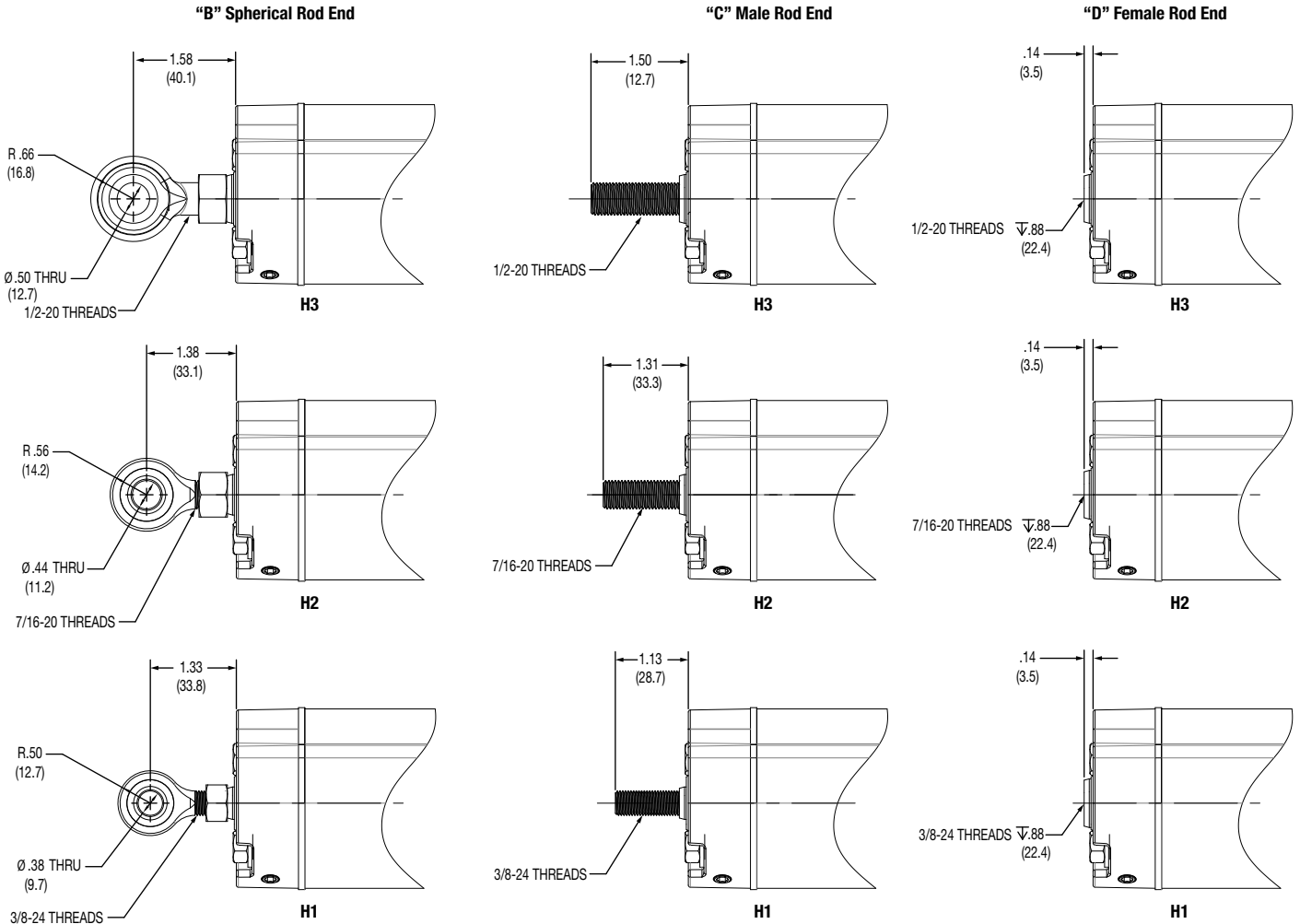

Dimensions

Bore/Rod Combo		Rod End "A"						Rod End "B"						Rod End "C"						Rod End "D"					
		H1		H2		H3		H1		H2		H3		H1		H2		H3		H1		H2		H3	
Stroke Length		"pp" INCH	"pp" MM	"pp" INCH	"pp" MM	"pp" INCH	"pp" MM	"pp" INCH	"pp" MM	"pp" INCH	"pp" MM	"pp" INCH	"pp" MM	"pp" INCH	"pp" MM	"pp" INCH	"pp" MM	"pp" INCH	"pp" MM	"pp" INCH	"pp" MM	"pp" INCH	"pp" MM	"pp" INCH	"pp" MM
2" (02)	50MM	6.8	173	6.8	173	6.8	173	7.5	190	7.4	191	7.7	196	7.1	181	7.3	186	7.5	191	6.2	157	6.2	157	6.2	157
4" (04)	100MM	8.8	224	8.8	224	8.8	224	9.5	241	9.5	242	9.7	247	9.1	232	9.3	237	9.5	242	8.2	208	8.2	208	8.2	208
6" (06)	150MM	10.8	274	10.8	274	10.8	274	11.5	292	11.5	293	11.7	298	11.1	283	11.3	288	11.5	292	10.2	259	10.2	259	10.2	259
8" (08)	200MM	12.8	325	12.8	325	12.8	325	13.5	342	13.5	344	13.7	349	13.1	334	13.3	338	13.5	343	12.2	310	12.2	310	12.2	310
10" (10)	254MM	14.8	376	14.8	376	14.8	376	15.5	393	15.5	395	15.7	400	15.1	385	15.3	389	15.5	394	14.2	361	14.2	361	14.2	361
12" (12)	300MM	16.8	427	16.8	427	16.8	427	17.5	444	17.5	445	17.7	450	17.1	435	17.3	440	17.5	445	16.2	411	16.2	411	16.2	411
14" (14)	350MM	18.8	478	18.8	478	18.8	478	19.5	495	19.5	496	19.7	501	19.1	486	19.3	491	19.5	496	18.2	462	18.2	462	18.2	462
16" (16)	400MM	20.8	528	20.8	528	20.8	528	21.5	546	21.5	547	21.7	552	21.1	537	21.3	542	21.5	546	20.2	513	20.2	513	20.2	513

"PP" = Pin to Pin Length as shown in chart on page 10 alongside the outline drawing for reference. All stroke dimensions are in inches, millimeter strokes are rounded.

H-Track Electric Linear Actuator System

Performance Data

Load Chart

Motor Code "1" 250 Watt Motor Performance

EXTENDING		RETRACTING				EXTENDING				RETRACTING			
Max Load LB	Max Load N	Max Load LB	Max Load N	Bore Code	Pump Code	No Load Speed IN	MM	Max Load Speed IN	MM	No Load Speed IN	MM	Max Load Speed IN	MM
500	2224	375	1668	H1	B4	3.5	88.9	1	25	4.38	111	1.25	32
750	3336	563	2502	H1	A4	2	50.8	0.6	15	2.50	64	0.75	19
1000	4448	750	3336	H1	B1	1.75	44.5	0.5	13	2.19	56	0.63	16
1250	5560	992	4411	H2	B3	1.4	35.6	0.4	10	1.69	43	0.48	12
1500	6672	1125	5004	H3	B3	1.2	30.5	0.35	8.9	1.50	38	0.44	11
1750	7784	1313	5838	H3	B2	1	25.4	0.29	7.4	1.25	32	0.36	9
2000	8896	1587	7058	H2	A2	0.65	16.5	0.19	4.8	0.78	20	0.23	6
2250	10008	1688	7506	H3	B1	0.8	20.3	0.23	5.8	1.00	25	0.29	7
2500	11121	1983	8823	H2	A1	0.5	12.7	0.15	3.8	0.60	15	0.18	5
3200	14234	2400	10676	H3	A1	0.45	11.4	0.13	3.3	0.56	14	0.16	4

Load Chart

Motor Code "2" 560 Watt Motor Performance

EXTENDING		RETRACTING				EXTENDING				RETRACTING			
Max Load LB	Max Load N	Max Load LB	Max Load N	Bore Code	Pump Code	No Load Speed IN	MM	Max Load Speed IN	MM	No Load Speed IN	MM	Max Load Speed IN	MM
750	3336	563	2502	H1	B4	3.5	89	1	25	4.38	111	1.25	32
1125	5004	844	3753	H1	A4	2	51	0.6	15	2.50	64	0.75	19
1500	6672	1125	5004	H1	B1	1.75	44	0.5	13	2.19	56	0.63	16
1875	8340	1488	6617	H2	B3	1.4	36	0.4	10	1.69	43	0.48	12
2250	10008	1688	7506	H3	B3	1.2	30	0.35	9	1.50	38	0.44	11
2625	11677	1969	8757	H3	B2	1	25	0.29	7	1.25	32	0.36	9
3000	13345	2380	10588	H2	A2	0.65	17	0.19	5	0.78	20	0.23	6
3375	15013	2531	11260	H3	B1	0.8	20	0.23	6	1.00	25	0.29	7
3750	16681	2975	13234	H2	A1	0.5	13	0.15	4	0.60	15	0.18	5
4800	21351	3600	16014	H3	A1	0.45	11	0.13	3	0.56	14	0.16	4

H-Track Electric Linear Actuator System

Electrical Data

Power Supply

Ensure the power supply is capable of delivering full rated voltage and current for your selected configuration actuator for the length of required run-time. See Power Supply Chart below.

Power Supply Chart			
Operating Code	Motor Code	Maximum Current Requirement	Nominal Operating Voltage
12	1	40 AMPS	12VDC
12	2	80 AMPS	12VDC
24	1	25 AMPS	24VDC
24	2	50 AMPS	24VDC
48	1	15 AMPS	48VDC
48	2	30 AMPS	48VDC

▲ IMPORTANT Maximum current requirement is the amount of current (AMPS) the power supply should be capable of supplying safely at the nominal operating voltage. It is not the operating current. Operating current draw of the H-Track actuator is load dependent. It will vary when/as load varies. It is recommended you evaluate the H-Track actuator in your application to determine your true maximum current draw.

Connections

It is important to correctly size wires routed from the power supply to the H-Track actuator. Below is a guide to assist in selecting the correct wires.

Current Amps	AWG				
	4	6	8	10	12
100	4	2	2	*	*
90	4	4	2	2	*
80	4	4	4	2	2
70	6	6	4	4	2
60	6	6	4	4	2
50	6	6	6	4	4
40	8	8	6	6	4
30	10	10	8	6	6
20	14	12	10	8	6
10	14	14	12	10	10
	5ft (1.5m)	10ft (3.0m)	15ft (4.6m)	20ft (6.1m)	25ft (7.6m)
	Length in Feet (m)				

*= not recommended

Fuse Recommendation for All Systems:

The fuse should be sized to 135% of full-load steady-state current.

Component Protection and DC Motors:

DC motors can produce large voltage and current spikes when powered on or off. Back-to-back Zener diodes across the motor are recommended to help suppress the large spike from affecting other sensitive components in the system. Use a 20V-30V back-to-back Zener for a 12VDC motor and a 30V-40V back-to-back Zener for a 24VDC motor. Consult the factory for further recommendations.

Application Consideration

The 12VDC 240 watt motor can consume 40 amps of current. For example, you need to provide 10 ft of wire from the power supply to the H-Track actuator. From the chart we find a recommendation for 8AWG wire. This chart is for 100% duty cycle and is based on ABYC E-11 (3% drop). With careful analysis you may find a smaller gauge wire is sufficient for your application.

Connectors are provided with each actuator. Packard 56 male connectors are provided with all motor code "1" regardless of voltage. 12 AWG ring terminals are provided for motor code "2" regardless of voltage. As a standard the male version is attached to the actuator motor at the factory and the female mate is included as a kit to be assembled by the end-user. Special connectors are available, consult the factory for assistance.

Fusing or circuit breakers are recommended for all H-Track installations. Fuse should be sized to be 135% of the full-load steady-state current draw.

H-Track Electric Linear Actuator System

Performance Graphs Imperial (Metric) Measurements*

*Performance Chart Measurements are Nominal

Actuator Speed

H-Track travel speed specifications are given as speed at maximum load and no-load speed. All values are given at 70°F (21°C) and at the normal operating voltage. See below graphs of speed versus load. Please consult Warner Linear Engineering for documentation. Care should be taken when using actuator speed to calculate cycle time. This is especially important if cycle time is critical for the application. It is important to understand travel speed can be affected by the operating environment. Operating temperature, actual voltage (voltage drop), varied load conditions, etc. can affect the speed and cycle time. It is recommended the H-Track is tested to determine actual cycle times.

A1 Pump Performance Motor Code 1

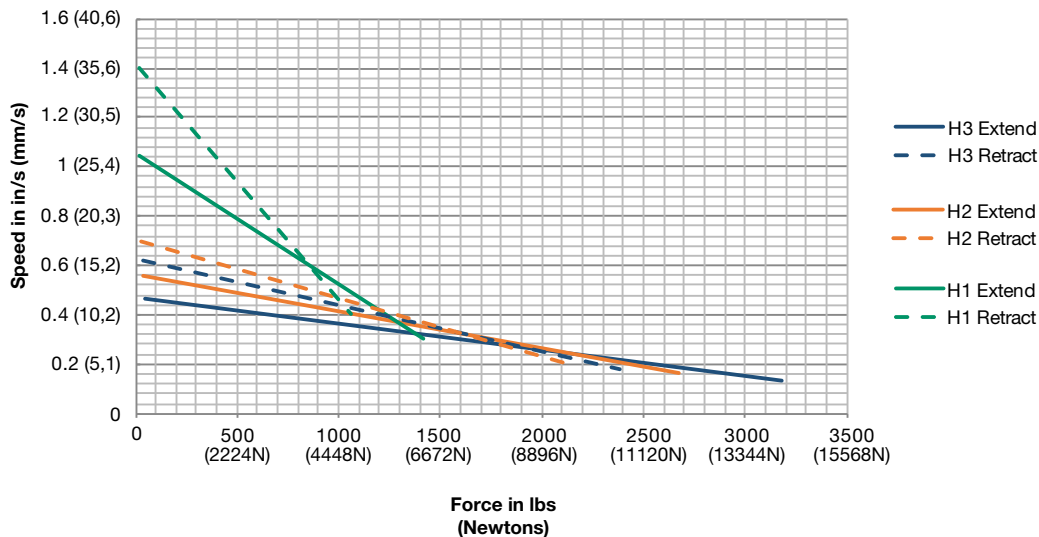

A2 Pump Performance Motor Code 1

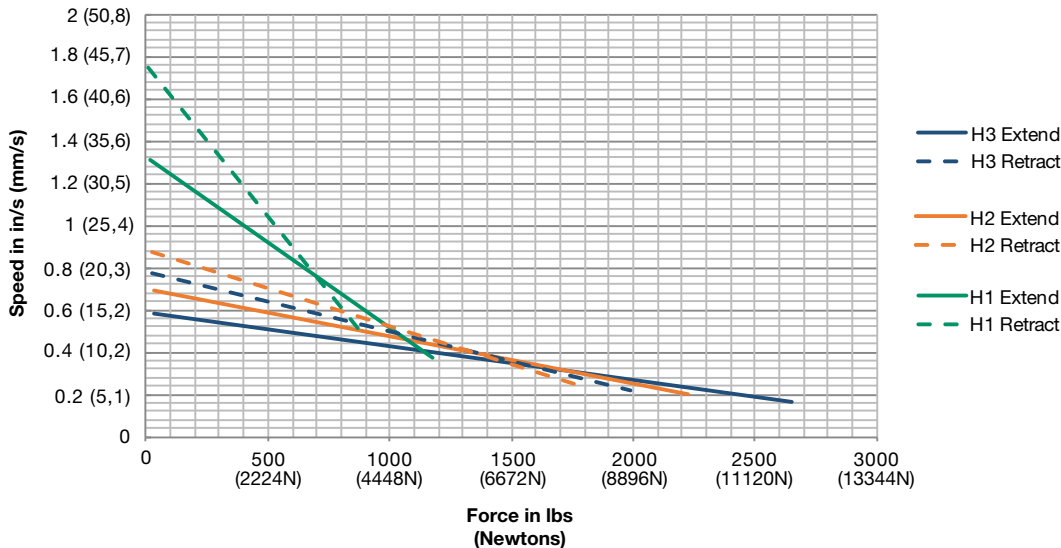

H-Track Electric Linear Actuator System

Performance Graphs Imperial (Metric)

Measurements*

*Performance Chart Measurements are Nominal

A3 Pump Performance Motor Code 1

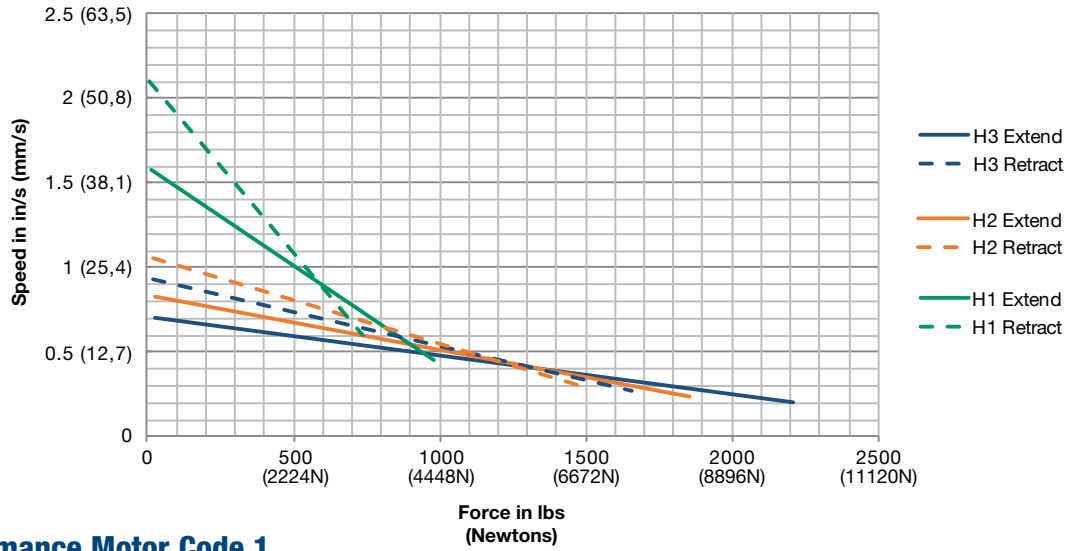

A4 Pump Performance Motor Code 1

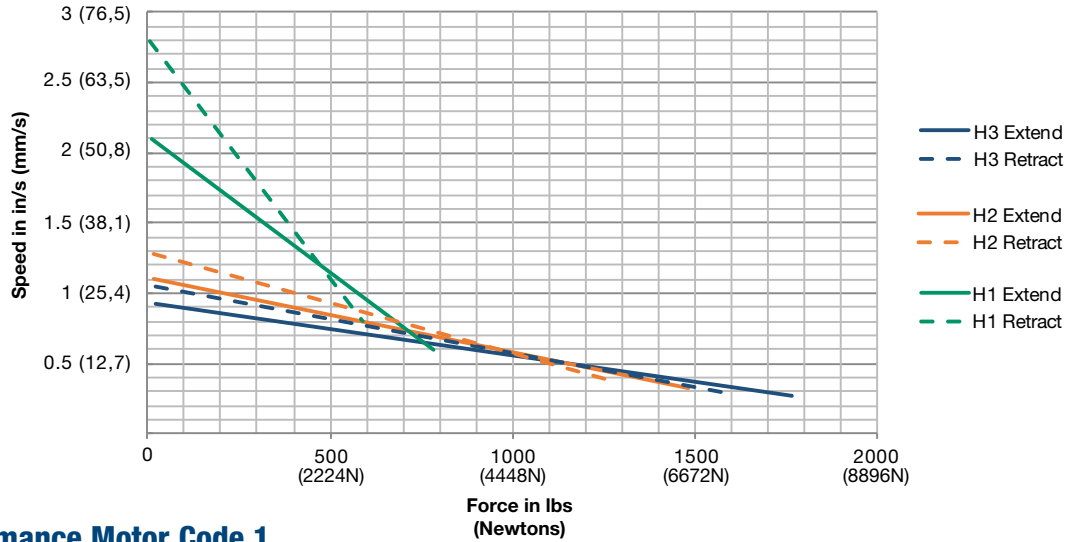

B1 Pump Performance Motor Code 1

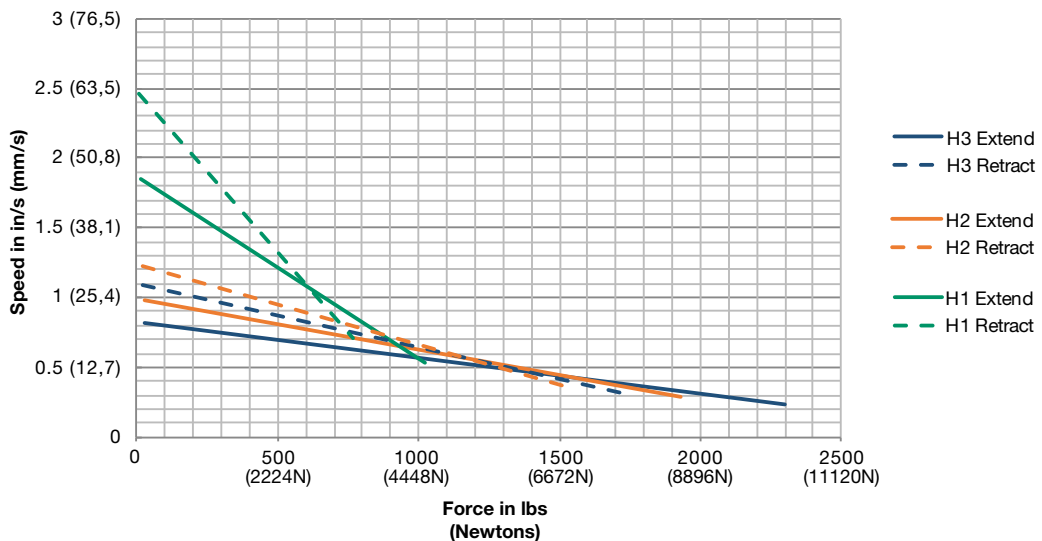

H-Track Electric Linear Actuator System

Performance Graphs Imperial (Metric) Measurements*

*Performance Chart Measurements are Nominal

B2 Pump Performance Motor Code 1

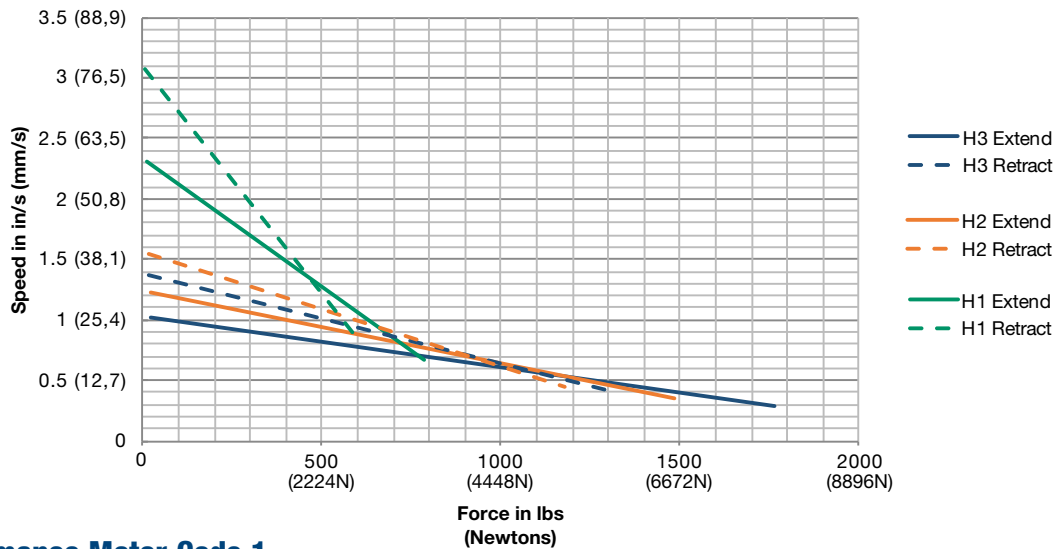

B3 Pump Performance Motor Code 1

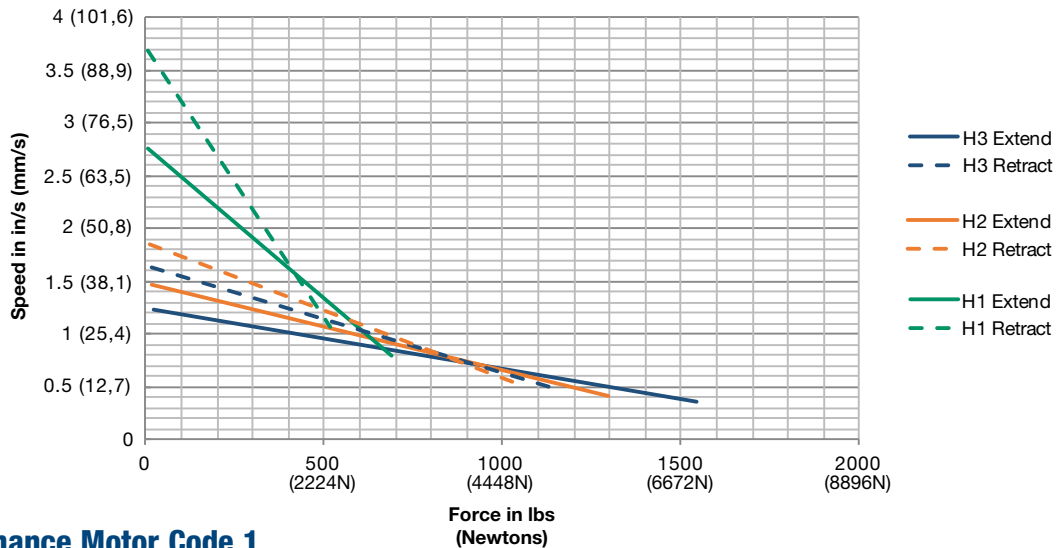

B4 Pump Performance Motor Code 1

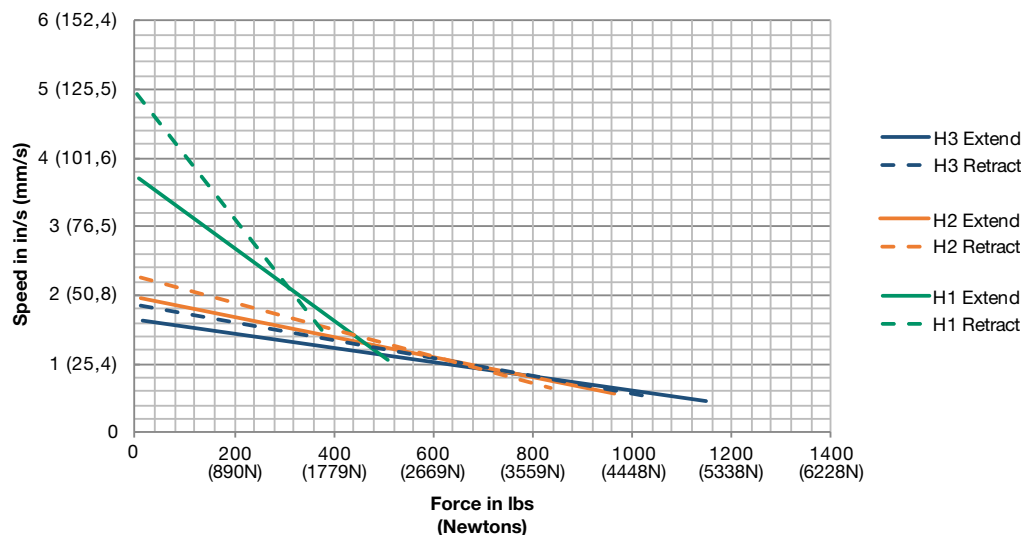

H-Track Electric Linear Actuator System

Compliance Matrix

DUT H3N-12-IA23-A06R90

Environment	Test Method	Definition
Sealing		
Inorganic Dust	WL-PVM-3.1.1 IEC SPECIFIED	Unit must meet IP69K operating IEC 60529
Particle Impact	WL-PVM-3.2 Custom based on SAE J1455	<p><u>Name:</u> Gravel Bombardment</p> <p><u>Media Size:</u> .96-1.6CM in diameter gravel</p> <p><u>Method of Delivery:</u> 1 cubic foot poured onto unit from a height of 1 meter</p> <p><u>Unit Orientation:</u> Cubic (six sides) in retracted position</p> <p><u>Duration:</u> 10 cycles in each orientation</p> <p><u>Pass-Fail Criteria:</u> Must be fully functional after test, cosmetic damage allowed, but no alteration in operation allowed</p> <p><u>Note:</u> Connectors must be mated</p>
Cleaning	WL-PVM-3.1 IEC SPECIFIED	Unit must meet IP69K per IEC 60529
Immersion	WL-PVM-3.5 IEC SPECIFIED	Per IP-67 operating per IEC 60529
Corrosion Resistance		
Chemical Resistance	WL-PVM-3.4 REFERENCE ASTM D3912	<p>Diesel Fuel</p> <p>Paint</p> <p>Ethylene Glycol</p> <p>Refrigerants</p> <p>Hydraulic Oil</p> <p>Lubricating Oil API CD (SAE J183)</p> <p>Coolant Conditioner</p> <p>Chlorox Solution (3%)</p> <p>R134a Refrigerant</p> <p>PAG Refrigerant Oil</p>
Salt Environment	WL-PVM-3.3 Ref ASTM B117-03	<p><u>Name:</u> Salt fog/spray</p> <p><u>Media Size:</u> Mist and direct spray 25psi .3GPM minimum through a .03" nozzle</p> <p><u>Method of Delivery:</u> WL Chamber EVW 50</p> <p><u>Unit Orientation:</u> Not applicable</p> <p><u>Duration:</u> 200 total hours</p> <p><u>Pass-Fail Criteria:</u> Must be fully functional after test, cosmetic damage allowed, but coatings must adhere. No alteration in operation allowed.</p> <p><u>Note:</u> Connectors must be mated</p>
Vibration and Mechanical Shock		
Swept Sine	WL-PVM-4.1	<p><u>Frequency:</u> Logarithmic sweep from 10Hz to 2000Hz</p> <p><u>Sweep Period:</u> 20 minutes</p> <p><u>Axis:</u> All 3 axes</p> <p><u>Displacement Limits:</u> 1.5MM from 10HZ to 91HZ</p> <p><u>Acceleration Limits:</u> 104m/sec² RMS 15G peak from 70.5Hz to 2000Hz</p> <p><u>Duration:</u> 8 hours per axis</p> <p><u>Orientation:</u> Horizon parallel to cylinder rod/bore axis</p> <p><u>Pass-Fail Criteria:</u> Must be fully functional after test, cosmetic damage allowed, but no alteration in operation allowed</p> <p><u>Note:</u> Connectors must be mated</p>
Operating Shock	CUSTOMER FIELD TEST	CUSTOMER TO DEFINED CONFIDENTIAL
Bench Handling	WL-PVM-4.3	<p><u>Height:</u> Drop from 1M</p> <p><u>Acceleration:</u> Gravity only</p> <p><u>Orientation:</u> Cubic 6 faces</p> <p><u>Duration:</u> 1 time each orientation</p> <p><u>Pass-Fail Criteria:</u> Must be fully functional after test, cosmetic damage allowed, but no alteration in operation allowed</p> <p><u>Note:</u> Connectors must not be mated</p>

H-Track Electric Linear Actuator System

Compliance Matrix

Environment	Test Method	Definition
Transit	WL-PVM-4.4	<p><u>Height:</u> Drop from 1.2M</p> <p><u>Acceleration:</u> Gravity only</p> <p><u>Orientation:</u> In packaging, bulk pack only</p> <p><u>Duration:</u> 1 time</p> <p><u>Pass-Fail Criteria:</u> Must be fully functional after test, cosmetic damage allowed, but no alteration in operation allowed</p> <p><u>Note:</u> Connectors must not be mated</p>
Installation	WL-PVM-4.5	<p><u>Height:</u> Drop from .2M do not reach ground must be restrained by wire harness.</p> <p><u>Acceleration:</u> Gravity only</p> <p><u>Orientation:</u> Not applicable</p> <p><u>Duration:</u> 6 times</p> <p><u>Pass-Fail Criteria:</u> Must be fully functional after test, cosmetic damage allowed, but no alteration in operation allowed. Crimps must be intact and meet Warner's non-destructive pull-test.</p> <p><u>Note:</u> Connectors must be mated</p>
TEMPERATURE / HUMIDITY		
Operational Temperature	WL-PVM-5.1.2	REFER TO COMBINED ENVIRONMENT SECTION 2.3.2
Humidity	WL-PVM-5.1.3	REFER TO COMBINED ENVIRONMENT SECTION 2.3.2
Storage Temperature	WL-PVM-5.0	REFER TO COMBINED ENVIRONMENT SECTION 2.3.2
Storage Humidity	WL-PVM-5.0	REFER TO COMBINED ENVIRONMENT SECTION 2.3.2
Thermal shock	WL-PVM-5.0	<p><u>TEMP MAX:</u> 70°C (158°F)</p> <p><u>TEMP MIN:</u> -40°C (-40°F)</p> <p><u>TRANSITION TIME:</u> LESS THAN 1 MINUTE</p> <p><u>CYCLE TIME:</u> 5 MINUTE SOAK AT EXTREME TEMPS measured at the motor shell</p> <p><u>NUMBER OF CYCLES:</u> 20</p>
RADIATION		
Ultraviolet Effects	ISO 4892 METHOD A	300 HOURS 100% UV EXPOSURE
Combined Environmental		
<p>Test in environmental chamber where temperature, humidity, voltage and load vary over a 12 hours equalling 1 cycle. The device under test must endure 51 cycles without loss of performance</p>	WL-PVM-2.3.2	Temperature varied from -20F to +150F over 12 hours
		Relative humidity varied from 10% to 90% over 12 hours
		Loading- varies from -500lbf (tensile) 1250lbf (compression) totaling 500 actuations in 12 hours
		Voltage varies from 9VDC to 16VDC

Combined Environment Schedule

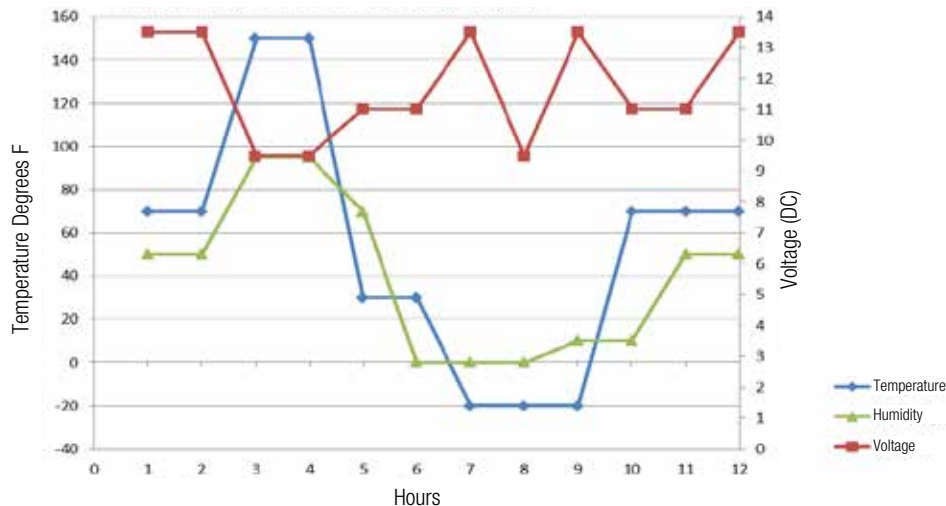

H-Track Electric Linear Actuator System

Glossary



Figure 1 Axial load

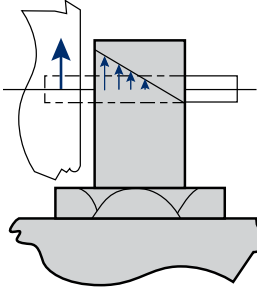

Figure 2 Cantilevered mount



Figure 3 For use with clevis mount



Figure 4 Compression load

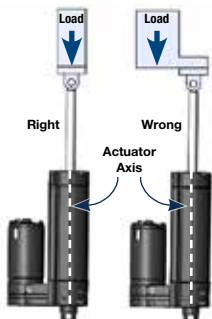

Figure 5 Eccentric load



Figure 6 Extended length

Axial Load

A load along the axis of the actuator screw (Figure 1).

Cantilevered Mount

A mounting where the mounting pin is not supported on both sides. Cantilevered mounts are common causes of failure (Figure 2).

Clevis Mount

A U-shaped metal piece that has the ends drilled to accept a pin or bolt through actuator mount holes (Figure 3).

Compression Load

Compression loading will press on the unit (Figure 4).

Current vs. Load

The current load on the motor is measured by amperes. Current draw will increase as load increases.

Cycle

Movement from a fully retracted to fully extended position and back to fully retracted.

Duty Cycle

The amount of 'on-time' vs 'total time.' A 25% duty cycle means that a unit operates for 10 seconds out of 40 seconds or 4 seconds out of 16 seconds.

Eccentric Load

An off-center load which may cause binding and shorten actuator life (Figure 5).

Extension Rate

The rate of speed at which the actuator extends or retracts. The impact of load on speed has a greater effect on DC units than AC units.

Efficiency

Ratio of input power to output power.

Extended Length

The overall length of the actuator from the center of the rear clevis to the center of the extension tube pin hole when the unit is at full extension (see figure 6).

Load

The force, measured in pounds, that is applied as an axial load on the actuator.

Load Holding

The ability of the actuator to hold a load stationary when power is off.

Peak Load

The maximum dynamic load that will be applied to the actuator or that the actuator is capable of moving.

Pin Mount

The use of a dowel or pin through the hole in the clevis mount on the rear of an actuator or the extension tube (on the front of an actuator) (Figure 7).



Figure 7 Pin mount

Radial Load

A load applied to the side of the rod or across the body of the actuator. Radial loading will have a negative impact on unit life (Figure 8).



Figure 8 Radial load also side loading

Retracted Length

The overall length of the actuator from the center of the rear clevis to the center of the extension tube pin hole when the unit is at full retracted position (Figure 9).



Figure 9 Retracted length

Side Load

See radial loading (Figure 8).

Static Load

The maximum non-operating (or non-moving) load. Static load is the load holding capability of an actuator.

Synchronous Operation

Having more than one actuator extend and retract together maintaining ± 0.20 position relative to each other.

Tension Load

A load that will tend to pull on the unit (Figure 10).

Thermal Overload

A switch within the motor that will stop the motor if it exceeds a safe heat level.

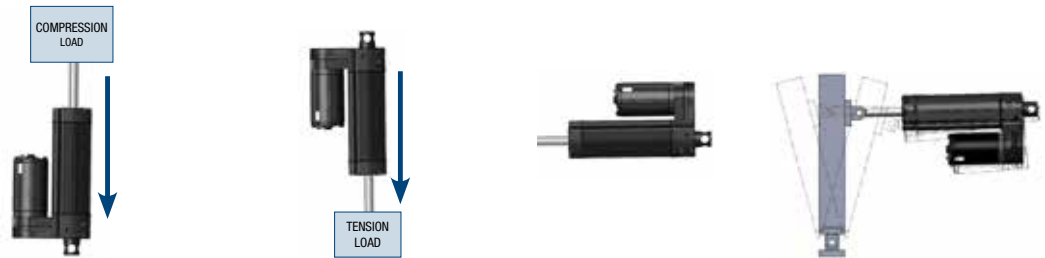

Figure 10 Tension load

H-Track Application Data Form

Send to: Thomson | 203A West Rock Road | Radford, VA 24141
 Email: thomson@thomsonlinear.com | Fax: 540.633.0294

Contact:					Date:		
Company:					Application:		
Location:					Cust. Project ID:		
PDR number:					EAU:		
Production Launch:					Target Cost:		
Electrical System:	Operating Voltage		Max VDC		Min VDC		Max Amp Draw
Cylinder Stroke:	inches						
Cylinder Bore/Rod:	Ø1.00"B Ø.50"R		Ø1.38"B Ø.63"R		Ø1.50"B Ø.625"R		
Electric Wire End:	Connector Requirement						
Time to extend/retract:	Speed under load IPS						
Temperature Range:	Min °F		Max °F				
Installation:	Indoor		Outdoor				
Mounting Angle: if applicable	Angle at Full Retract						
	Angle at Full Extend						
Vibration in Application:	Yes/No	Vibration Specification/ Summary					
Duty Cycle:	Cycles/Day		Days/Year				
	Minutes Between Cycles						
	Machine Life Hours						
Load on Cylinder:	Compression		Tension		Horizontal		Tension and Compression



Reduced Force Req'd: Retract Extend

Static Loading: Minimum Maximum lbs

Actuator Force Required: Extension Retraction lbs

Additional Notes:

Altra Seller:

Account ID #:

Model Code:

ONLINE RESOURCES

Thomson offers a wide variety of online resources to help you learn more about electric linear actuators. An experienced team of application engineers is also available to help you. To explore additional technical resources and options, contact Thomson customer support at www.thomsonlinear.com/cs.

Smart Actuators Product Website

Learn more about smart actuators and how they can help you build better machines at: www.thomsonlinear.com/smart

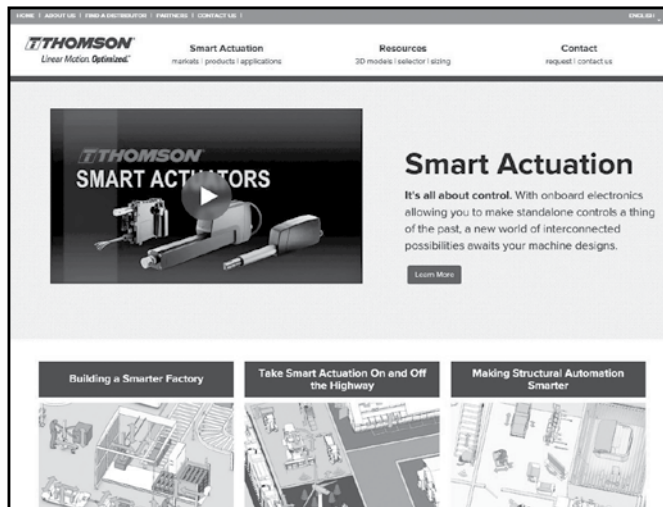

Free CAD Models

Download free interactive 3D CAD models in the most common CAD formats at: www.thomsonlinear.com/en/products/linear-actuators-drawings

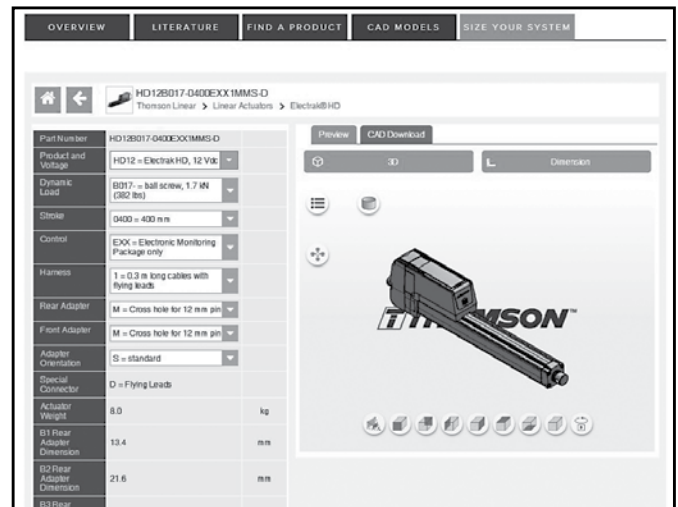

Electrak® HD Product Website

Get additional information and learn more about Electrak HD at: www.thomsonlinear.com/hd

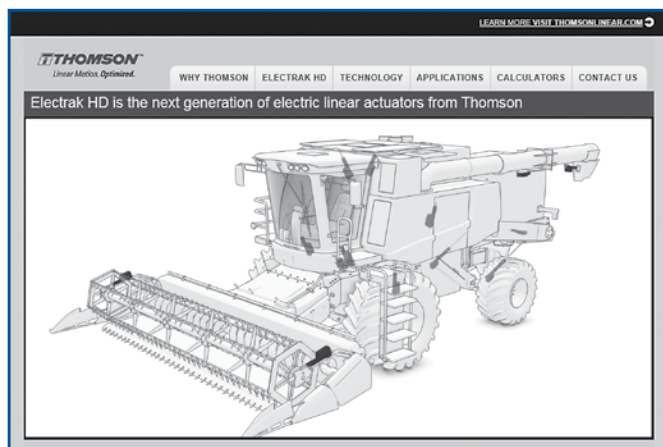

Mobile Off-Highway Product Website

Learn how actuators can be used in mobile off-highway vehicles at: www.thomsonlinear.com/moh

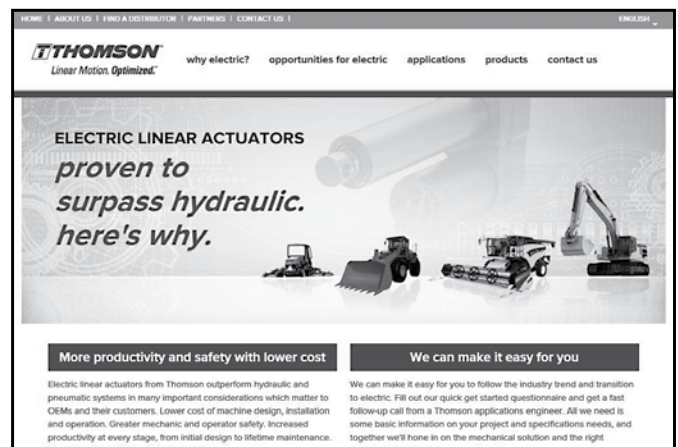

EUROPE

United Kingdom

Thomson
Office 9, The Barns
Caddsdow Business Park
Bideford, Devon, EX39 3BT
Phone: +44 1271 334 500
E-mail: sales.uk@thomsonlinear.com

Germany

Thomson
Nürtinger Straße 70
72649 Wolfschlugen
Phone: +49 7022 504 403
Fax: +49 7022 504 405
E-mail: sales.germany@thomsonlinear.com

France

Thomson
Phone: +33 243 50 03 30
Fax: +33 243 50 03 39
E-mail: sales.france@thomsonlinear.com

Italy

Thomson
Via per Cinisello 95/97
20834 Nova Milanese (MB)
Phone: +39 0362 366406
Fax: +39 0362 276790
E-mail: sales.italy@thomsonlinear.com

Spain

Thomson
E-mail: sales.esm@thomsonlinear.com

Sweden

Thomson
Estridsväg 10
29109 Kristianstad
Phone: +46 44 24 67 00
Fax: +46 44 24 40 85
E-mail: sales.scandinavia@thomsonlinear.com

SOUTH AMERICA

Brasil

Thomson
Av. João Paulo Ablas, 2970
Jardim da Glória - Cotia SP - CEP: 06711-250
Phone: +55 11 4615 6300
E-mail: sales.brasil@thomsonlinear.com

USA, CANADA and MEXICO

Thomson
203A West Rock Road
Radford, VA 24141, USA
Phone: +1 540 633 3549
Fax: 1 540 633 0294
E-mail: thomson@thomsonlinear.com
Literature: literature.thomsonlinear.com

ASIA

Asia Pacific

Thomson
E-mail: sales.apac@thomsonlinear.com

China

Thomson
Rm 805, Scitech Tower
22 Jianguomen Wai Street
Beijing 100004
Phone: +86 400 606 1805
Fax: +86 10 6515 0263
E-mail: sales.china@thomsonlinear.com

India

Thomson
c/o Portescap India Pvt Ltd
1 E, first floor, Arena House
Road no 12, Marol Industrial Area,
Andheri (E), Mumbai 400093 India
E-mail: sales.india@thomsonlinear.com

Japan

Thomson
Minami-Kaneden 2-12-23, Suita
Osaka 564-0044 Japan
Phone: +81 6 6386 8001
Fax: +81 6 6386 5022
E-mail: csjapan@scgap.com

South Korea

Thomson
3033 ASEM Tower (Samsung-dong)
517 Yeongdong-daero
Gangnam-gu, Seoul, South Korea (06164)
Phone: + 82 2 6001 3223 & 3244
E-mail: sales.korea@thomsonlinear.com