

ENGINEERING  
TOMORROW



Technical Information

# shhark<sup>®</sup> Low Noise Gear Pumps

## Group 2

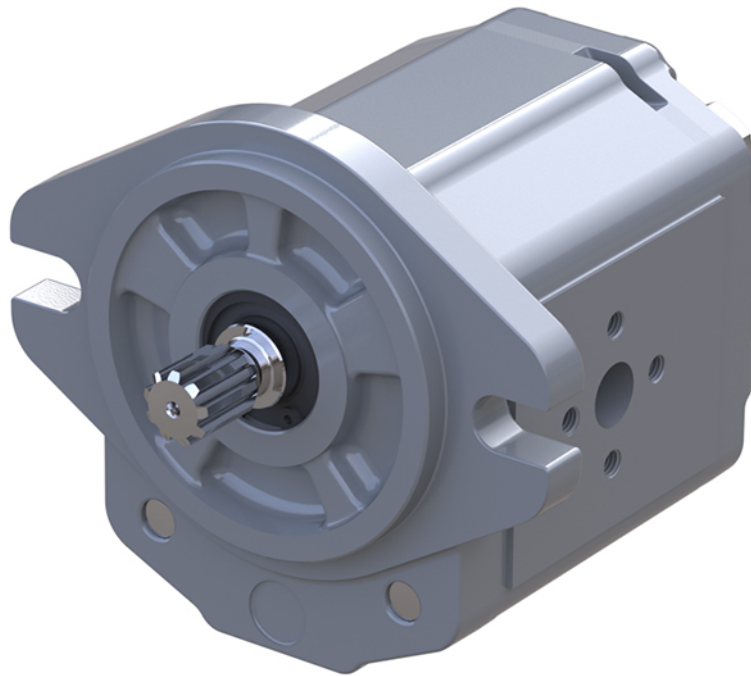

**Revision history***Table of revisions*

<b>Date</b>	<b>Changed</b>	<b>Rev</b>
February 2020	Added frame size 025 sound levels graphs	0105
November 2019	Minor edits to text, tables and the diagrams in "Dimensions and Data"	0104
October 2019	Features text change on page 6.	0103
October 2019	New images replacement.	0102
September 2019	First edition.	0101

## Contents

### General information

The shhark® Low Noise Technology.....	4
Features and Benefits.....	5
shhark® Gear Pumps Representatives.....	5
Advantage of the shhark® versus the “double-flank contact” technology.....	6
shhark® Pump Design.....	6
shhark® Technical Data.....	7
Determination of Nominal Pump Sizes.....	8

### Master Model Code

Model Code for Single Gear Pumps.....	11
Model Code for Tandem Gear Pumps.....	12
Model Code for Tandem Gear Pumps.....	14

### System Requirements

Inlet Pressure.....	16
Speed.....	17
Hydraulic Fluids.....	17
Temperature and Viscosity.....	18
Filtration.....	19
Filters.....	19
Selecting a filter.....	19
Reservoir.....	19
Line sizing.....	20
Pump Drive.....	20
Pump Life.....	21
Sound Level.....	21

### Sound Level Graphs

Frame size 8,0 sound levels graph.....	22
Frame size 011 sound levels graph.....	23
Frame size 014 sound levels graph.....	24
Frame size 017 sound levels graph.....	25
Frame size 019 sound levels graph.....	26
Frame size 022 sound levels graph.....	27
Frame size 025 sound levels graph.....	28

### Pump Performance Graphs

Performance Graphs for Frame Size 8,0 and 011.....	29
Performance Graphs for Frame Size 014 and 017.....	29
Performance Graphs for Frame Size 019, 022 and 025.....	30

### Product Options

Standard Flange, Shaft and Ports Configuration Overview.....	31
Shaft Options.....	32
Pumps with integral relief valve • SHHP2EN and SHHP2IN.....	33
Integral relief valve covers SHHP2EN and SHHP2IN.....	34
Model Codes for Integral Relief Valve.....	35

### Dimensions and Data

SHHP2NN – 01BA.....	36
SHHP2NN – 02AA.....	37
SHHP2NN – 03CA.....	38
SHHP2NN – 04/05AA.....	39
SHHP2NN – 06SB, 06SA and 06GA.....	40
SHHP2NN – 06SA..BxBxYY../.....	41

**General information**

**The shhark® Low Noise Technology**

The standard technology currently used in low noise gear pumps is based on double-flank contact. This solution reduces the peak-to-peak flow pulsation by 75% compared to a single-flank contact gear pumps with the same number of teeth.

The Danfoss shhark® achieves the same reduction of flow pulsation, but in a totally different way. As illustrated below, for the same outer diameter, shhark® gears feature almost twice the number of teeth of a standard gear pump, thanks to a revolutionary asymmetric tooth profile design. Moreover, the shhark® teeth are also slightly helical; the small helix angle does not generate any additional radial and axial load but makes the flow characteristic smoother, further reducing the flow pulsation.

*Standard gear pump (11-teeth) versus shhark® (19-teeth) technology*



The comparison between the flow characteristic of Danfoss SKP2 (11-teeth) and shhark® (19-teeth) is illustrated in the plot below: the reduction of peak-to-peak flow pulsation is 78%. In addition, the average flow per unit width of shhark® is approximately 2.7% higher than SKP2; this means that for the exact same pump dimensions, shhark® delivers more flow.

*Flow characteristics of shhark® vs SKP2 standard*

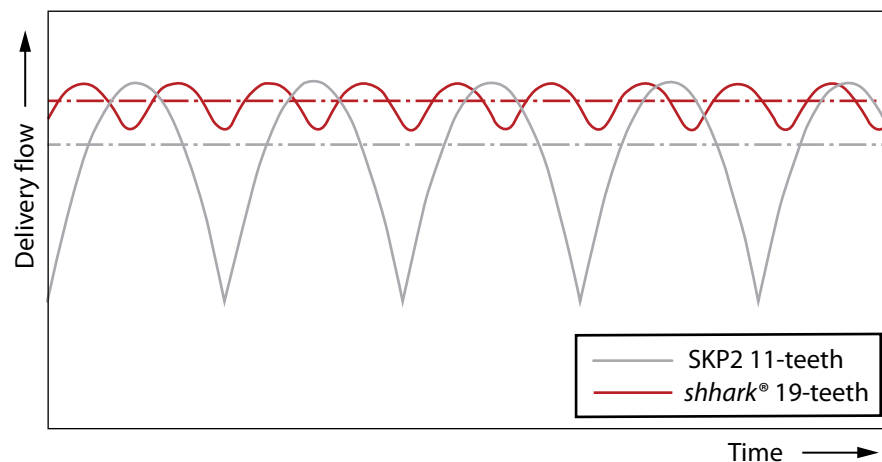

**General information**

**Features and Benefits**

- Noise level emissions reduced up to 10 dB(A)
- Low noise performance guaranteed throughout the whole life of the pump
- Low vibration, flow pulsation reduced by a stunning 78%
- Higher volumetric efficiency than a standard gear pump by 2%
- Wide range of displacements from 6.18 to 29 cm<sup>3</sup>/rev
- Rated pressure up to 250 bar
- Operating speed up to 4000 rpm
- SAE, DIN and European standard mounting flanges and shafts
- Available with integral relief valve
- Interchangeable with all standard gear pumps
- Multiple pump configurations, available also with standard gear products such as SNP1, SNP2, SKP2 and SNP3
- Compact and lightweight
- Helps to meet legal NVH requirements
- Innovative solution (Danfoss Patents US 20150330387 (A1) and WO2017064046 (A1))
- Ideal for hybrid and full electric machines for which the hydraulic pump is the most important source of noise together with fan drive
- Improved time to market due to elimination of end-of-line noise reduction measures

**shhark® Gear Pumps Representatives**

Many combinations of the gear pumps are available as multiple units made to fit any need.



## General information

### Advantage of the shhark® versus the “double-flank contact” technology

The effectiveness of double-flank contact is very likely to decrease throughout the pump’s life, because external gear units often work at high pressure with high level of contaminants in the hydraulic fluid.

In such conditions, the critical components of the rotating kit slowly wear out, with a progressive loss of the double-flank contact condition and with it, the low noise performance.

---

shhark® pumps are able to keep low noise performance even after thousands of hours of heavy duty operation in the field, while the dual contact flank pump starts emitting noise in the same conditions due to gears wearing. In addition, shhark® emits noise at lower frequency than the dual contact flank technology, resulting in a more acceptable sound for the human ear.

---

### shhark® Pump Design

In terms of rated operating range (speed, pressure and temperature), overall dimensions and available configurations, the shhark® has been designed to be essentially a low noise version of SKP2 pump.

The 20 mm shaft can accommodate any type of drive end, such as:

- SA (SAE 9-teeth 16/32)
- SB (SAE 11-teeth 16/32)
- RA (SAE 13-teeth 16/32)
- AA (Taper 1:5)
- BA (Taper 1:8)
- GA (Parallel SAE Ø15.875)
- CA (Tang 8x17.8)

As for SKP2, the hydrostatic compensation system is on the bearing blocks to ensure high efficiency, more compact tandem combinations and higher flexibility to distributors.

*SHHP2NN 06SB cutaway view*

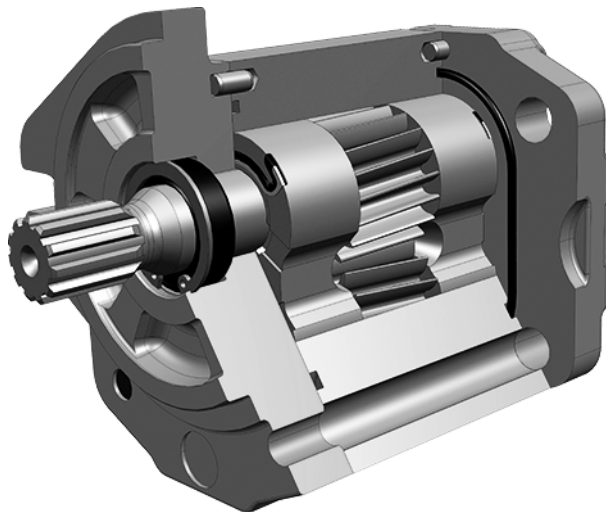

**General information**
**shhark® Technical Data**

The table below details the technical data for shhark® gear pumps based on the model and displacement configuration.

*Technical data for SHHP2*

Feature	Unit	Frame size						
		8.0	011	014	017	019	022	025
<b>Displacement</b>	cm <sup>3</sup> /rev [in <sup>3</sup> /rev]	8.7 [0.53]	11.1 [0.68]	14.8 [0.90]	17.3 [1.06]	19.8 [1.21]	23.5 [1.43]	25.94 [1.58]
<b>Peak pressure</b>	bar [psi]	280 [4060]	280 [4060]	280 [4060]	280 [4060]	260 [3770]	230 [3335]	200 [2900]
<b>Rated pressure</b>		250 [3625]	250 [3625]	250 [3625]	250 [3625]	240 [3480]	210 [3045]	190 [2755]
<b>Minimum speed at 0-100 bar</b>	min <sup>-1</sup> (rpm)	600	500	500	500	500	500	500
<b>Minimum speed at 100-180 bar</b>	min <sup>-1</sup> (rpm)	1000	800	750	750	700	700	700
<b>Minimum speed at 180 bar to rated pressure</b>	min <sup>-1</sup> (rpm)	1400	1200	1000	1000	1000	800	800
<b>Maximum speed</b>		4000	4000	3500	3000	3000	3000	3000
<b>Weight</b>	kg [lb]	2.5 [5.5]	2.7 [5.5]	2.9 [6.3]	3.0 [6.5]	3.1 [6.7]	3.2 [7.0]	3.4 [7.5]
<b>Moment of inertia of rotating components</b>	x 10 <sup>-6</sup> kg·m <sup>2</sup> [- <sup>6</sup> lb·ft <sup>2</sup> ]	32.4 [769]	38.4 [911]	47.3 [1122]	53.3 [1265]	59.2 [1405]	68.1 [1616]	71.1 [1687]
<b>Theoretical flow at maximum speed</b>	l/min [US gal/min]	34.8 [9.2]	44.4 [11.7]	51.8 [13.7]	51.9 [13.7]	59.4 [15.7]	70.5 [18.6]	77.8 [20.6]

$$1 \text{ kg}\cdot\text{m}^2 = 23.68 \text{ lb}\cdot\text{ft}^2$$

**Caution**

The rated and peak pressure mentioned in the table are for pumps with flanged ports only. When threaded ports are required a de-rated performance has to be considered. To verify the compliance of a high pressure application with a threaded ports pump apply to a Danfoss representative.

**General information**
**Determination of Nominal Pump Sizes**

Generally, the sizing process is initiated by an evaluation of the machine system to perform the necessary work function. The following formulae can be used to determine the nominal pump size for a specific application.

	Metric System	Inch System
<b>Output flow</b>	$Q_e = \frac{V_g \cdot n \cdot \eta_v}{1000}$ (l/min)	$Q_e = \frac{V_g \cdot n \cdot \eta_v}{231}$ (US gal/min)
<b>Input torque</b>	$M_e = \frac{V_g \cdot \Delta p}{20 \cdot \pi \cdot \eta_m}$ (N·m)	$M_e = \frac{V_g \cdot \Delta p}{2 \cdot \pi \cdot \eta_m}$ (lbf·in)
<b>Input power</b>	$P_e = \frac{M_e \cdot n \cdot \pi}{30\,000} = \frac{Q_e \cdot \Delta p}{600 \cdot \eta_t}$ (kW)	$P_e = \frac{M_e \cdot n \cdot \pi}{198\,000} = \frac{Q_e \cdot \Delta p}{1714 \cdot \eta_t}$ (hp)

Variables:

**V<sub>g</sub>** = Displacement per rev.  
**p<sub>HP</sub>** = High pressure  
**p<sub>NP</sub>** = Low pressure  
**Δp** = p<sub>HP</sub> - p<sub>NP</sub>  
**n** = Input speed  
**η<sub>v</sub>** = Volumetric efficiency  
**η<sub>m</sub>** = Mechanical (torque) efficiency  
**η<sub>t</sub>** = Overall efficiency (η<sub>v</sub> · η<sub>m</sub>)

SI units [US units]:

cm<sup>3</sup>/rev [in<sup>3</sup>/rev]  
 bar [psi]  
 bar [psi]  
 bar [psi]  
 min<sup>-1</sup> (rpm)



**Master Model Code**
**Model Code for Single Gear Pumps**

*A – Family*

<b>SHHP2NN</b>	Low-noise Group 2 gear pump
<b>SHHP2EN</b>	Low-noise Group 2 gear pump with external drain for relief valve*
<b>SHHP2IN</b>	Low-noise Group 2 gear pump with internal drain for relief valve

\* For this option please contact your Danfoss representative.

*B – Frame size and Displacement*

<b>6,0</b>	6.18 cm <sup>3</sup> *
<b>8,0</b>	8.7 cm <sup>3</sup>
<b>011</b>	11.1 cm <sup>3</sup>
<b>014</b>	14.8 cm <sup>3</sup>
<b>017</b>	17.3 cm <sup>3</sup>
<b>019</b>	19.8 cm <sup>3</sup>
<b>022</b>	23.5 cm <sup>3</sup>
<b>025</b>	25.94cm <sup>3</sup>

\* Frame size 028 is available upon a request.

*C – Direction of Rotation*

<b>L</b>	Left hand (Counter-clockwise)
<b>R</b>	Right hand (Clockwise)

*D – Project version*

<b>N</b>	Standard gear pump
----------	--------------------

*E – Mounting flange*

<b>01</b>	Pilot Ø36.5 mm; 4 holes
<b>02</b>	Pilot Ø80 mm; 4 holes
<b>03</b>	Pilot Ø52 mm; O-ring; 4 holes through body
<b>04</b>	Pilot Ø50 mm; 2 holes through body
<b>A4</b>	Pilot Ø50 mm; 2 holes through body; Seal on pilot
<b>05</b>	Pilot Ø50 mm; 2 holes through body
<b>06</b>	SAE A pilot Ø82.55 mm; 2 holes
<b>A6</b>	SAE A pilot Ø82.55 mm; 2 holes; Seal on pilot
<b>07</b>	SAE B pilot Ø101.6 mm; 2 holes

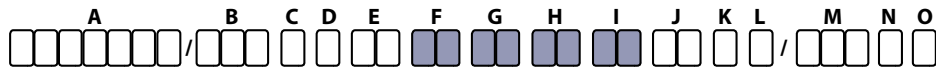
**Master Model Code**
**Model Code for Single Gear Pumps**

*F – Drive gear*

<b>AA</b>	Taper 1:5; M12x1.25 with Key 3
<b>BA</b>	Taper 1:8; M12x1.25 with Key 4
<b>CA</b>	Tang 8 x Ø17.8 x 6.5
<b>GA</b>	Parallel SAE Ø15.875 x 23.8; Key 4x18
<b>SA</b>	Spline SAE J498-9T-16/32DP
<b>SB</b>	Spline SAE J498-11T-16/32DP
<b>RA</b>	Spline SAE J498-13T-16/32DP

*G – Rear cover*

<b>E1</b>	Rear cover for pump with relief valve with external drain 3/8 Gas
<b>E3</b>	Rear cover for pump with relief valve with external drain 3/8 Gas with M5 holes
<b>I1</b>	Rear cover for pump with relief valve with internal drain
<b>I3</b>	Rear cover for pump with relief valve with internal drain with M5 holes
<b>P1</b>	Standard cover for pump
<b>P3</b>	Standard cover for pump with M5 holes

**H – Inlet and I – Outlet ports dimensions**

Code	Dimensions	Ports	Code	Thread Dimensions
<b>B5</b>	15x35xM6		<b>D5</b>	M18x1.5
<b>B6</b>	15x40xM6		<b>D7</b>	M22x1.5
<b>B7</b>	20x40xM6		<b>E4</b>	3/4-16UNF
<b>C3</b>	13.5x30xM6		<b>E5</b>	7/8-14UNF
<b>C5</b>	13.5x40xM8		<b>E6</b>	1 <sup>1</sup> / <sub>16</sub> -12UN
<b>C7</b>	20x40xM8		<b>F3</b>	3/8 Gas
<b>MB</b>	12 x 38.1 x 17.48 x M8 (=)		<b>F4</b>	1/2 Gas
<b>MC</b>	18.5 x 47.63 x 22.23 x M6 (=)		<b>F5</b>	3/4 Gas
<b>MD</b>	18.5 x 47.63 x 22.23 x M8 (=)		<b>F6</b>	1 Gas
<b>ME</b>	18.5 x 47.63 x 22.23 x M10 (=)		<b>H5</b>	M18 x 1.5 per ISO6149
<b>MG</b>	25/20 x 52.37 x 26.19 x M10 (=)		<b>H7</b>	M22 x 1.5 per ISO6149
<b>NN</b>	Without outlet port <u>To be used with rear ported units only.</u>		<b>H8</b>	M27 x 2 per ISO6149
		<b>H9</b>	M33 x 2 per ISO6149	

**Master Model Code**
**Model Code for Single Gear Pumps**

*J – Ports positions and special body*

<b>NN</b>	Standard from catalogue
<b>YY</b>	Port Bx-Bx with flange SAE-A; off-set to rear cover to install fitting screws

*K – Seals*

<b>G</b>	Viton shaft seal + HNBR pressure seals
<b>N</b>	Standard NBR seals
<b>D</b>	Viton shaft seal + NBR seals

*L – Screws*

<b>N</b>	Standard burnished screws
<b>A</b>	Zinc plated screws
<b>B</b>	Geomet screws

*M – Valve setting*

<b>NNN</b>	No valve
<b>V**</b>	Integral relief valve pressure setting

*N – Type marking*

<b>N</b>	Standard Danfoss marking
<b>A</b>	Standard Danfoss marking + Customer code
<b>Z</b>	No marking

*O – Marking position*

<b>N</b>	Standard marking on the top
<b>A</b>	Special marking position at the bottom

**Master Model Code**

**Model Code for Tandem Gear Pumps**

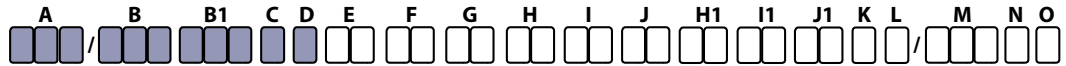

*A – Family*

<b>PKK</b>	
<b>PKL</b>	Low-noise Group 2 gear pumps
<b>PLK</b>	
<b>EKK</b>	
<b>EKL</b>	Low-noise Group 2 gear pump with external drain for relief valve*
<b>ELK</b>	
<b>IKK</b>	
<b>IKL</b>	Low-noise Group 2 gear pump with internal drain for relief valve
<b>ILK</b>	

\* For this option please contact your Danfoss representative.

*B – Pump 1st frame size and B1 – Pump 2nd frame size displacement*

<b>6,0</b>	6.18 cm <sup>3</sup> *
<b>8,0</b>	8.7 cm <sup>3</sup>
<b>011</b>	11.1 cm <sup>3</sup>
<b>014</b>	14.8 cm <sup>3</sup>
<b>017</b>	17.3 cm <sup>3</sup>
<b>019</b>	19.8 cm <sup>3</sup>
<b>022</b>	23.5 cm <sup>3</sup>
<b>025</b>	25.94 cm <sup>3</sup> **

\* Frame size 028 is available upon a request.

\*\* Frame size 025 is available for **B** only.

*C – Direction of Rotation*

<b>L</b>	Left hand (Counter-clockwise)
<b>R</b>	Right hand (Clockwise)

*D – Project version*

<b>N</b>	Standard gear pump
----------	--------------------

**Master Model Code**

**Model Code for Tandem Gear Pumps**

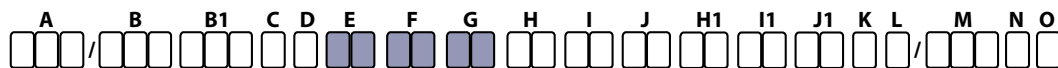

*E – Mounting flange*

<b>01</b>	Pilot Ø36.5 mm; 4 holes
<b>02</b>	Pilot Ø80 mm; 4 holes
<b>04</b>	Pilot Ø50 mm; 2 holes through body
<b>A4</b>	Pilot Ø50 mm; 2 holes through body; Seal on pilot
<b>05</b>	Pilot Ø50 mm; 2 holes through body
<b>06</b>	SAE A pilot Ø82.55 mm; 2 holes
<b>A6</b>	SAE A pilot Ø82.55 mm; 2 holes; Seal on pilot
<b>07</b>	SAE B pilot Ø101.6 mm; 2 holes

*F – Drive gear*

<b>AG</b>	Taper 1:5; M12x1.25 with Key 3
<b>BQ</b>	Taper 1:8; M12x1.25 with Key 4
<b>SM</b>	Spline SAE J498-9T-16/32DP
<b>SS</b>	Spline SAE J498-11T-16/32DP
<b>RB</b>	Spline SAE J498-13T-16/32DP

*G – Rear cover*

<b>E1</b>	Rear cover for pump with relief valve with external drain 3/8 Gas
<b>E3</b>	Rear cover for pump with relief valve with external drain 3/8 Gas with M5 holes
<b>I1</b>	Rear cover for pump with relief valve with internal drain
<b>I3</b>	Rear cover for pump with relief valve with internal drain with M5 holes
<b>P1</b>	Standard cover for pump
<b>P3</b>	Standard cover for pump with M5 holes

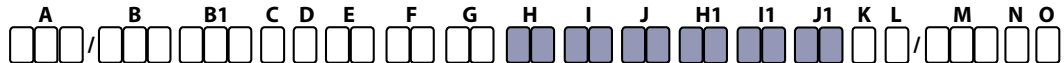
**Master Model Code**
**Model Code for Tandem Gear Pumps**

**H/H1 – Inlet and I/I1 – Outlet ports dimensions**

Code	Dimensions	Ports	Code	Thread Dimensions
<b>B5</b>	15x35xM6		<b>D5</b>	M18x1.5
<b>B6</b>	15x40xM6		<b>D7</b>	M22x1.5
<b>B7</b>	20x40xM6		<b>E4</b>	3/4-16UNF
<b>C3</b>	13.5x30xM6		<b>E5</b>	7/8-14UNF
<b>C5</b>	13.5x40xM8		<b>E6</b>	1 <sup>1</sup> / <sub>16</sub> -12UN
<b>C7</b>	20x40xM8		<b>F3</b>	3/8 Gas
<b>MB</b>	12 x 38.1 x 17.48 x M8 (=)		<b>F4</b>	1/2 Gas
<b>MC</b>	18.5 x 47.63 x 22.23 x M6 (=)		<b>F5</b>	3/4 Gas
<b>MD</b>	18.5 x 47.63 x 22.23 x M8 (=)		<b>F6</b>	1 Gas
<b>ME</b>	18.5 x 47.63 x 22.23 x M10 (=)		<b>H5</b>	M18 x 1.5 per ISO6149
<b>MG</b>	25/20 x 52.37 x 26.19 x M10 (=)		<b>H7</b>	M22 x 1.5 per ISO6149
<b>NN</b>	Without outlet port <a href="#">To be used with rear ported units only.</a>		<b>H8</b>	M27 x 2 per ISO6149
			<b>H9</b>	M33 x 2 per ISO6149

**J and J1 – Ports positions and special body**

<b>NN</b>	Standard from catalogue
<b>YY</b>	Port Bx-Bx with flange SAE-A; off-set to rear cover to install fitting screws

**Master Model Code**

**Model Code for Tandem Gear Pumps**

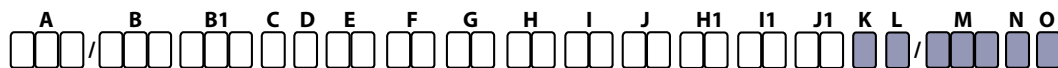

*K – Seals*

<b>G</b>	Viton shaft seal + HNBR pressure seals
<b>N</b>	Standard NBR seals
<b>D</b>	Viton shaft seal + NBR seals

*L – Screws*

<b>N</b>	Standard burnished screws
<b>A</b>	Zinc plated screws
<b>B</b>	Geomet screws

*M – Valve setting*

<b>NNN</b>	No valve
<b>V**</b>	Integral relief valve pressure setting

*N – Type marking*

<b>N</b>	Standard Danfoss marking
<b>A</b>	Standard Danfoss marking + Customer code
<b>Z</b>	No marking

*O – Marking position*

<b>N</b>	Standard marking on the top
<b>A</b>	Special marking position at the bottom

## System Requirements

### Inlet Pressure

**Peak pressure** is the highest intermittent pressure allowed at the pump's outlet. Peak pressure depends on the relief valve over shoot (reaction time).

**Rated pressure** is the maximum continuous operating pressure. The maximum machine load demand determines rated pressure.

**Inlet Vacuum** must be controlled in order to preserve pump's expected life and performance.

The system design must meet inlet pressure requirements during all operation modes. Expected lower inlet pressures during cold start will be improved as soon as the fluid warms up.

Max. continuous inlet vacuum	Maximum pressure
0.7 bar absolute [20.7 in. Hg]	4.0 bar absolute [118.1 in. Hg]

The illustration below shows peak pressure in relation to rated pressure and reaction time (100 ms maximum).

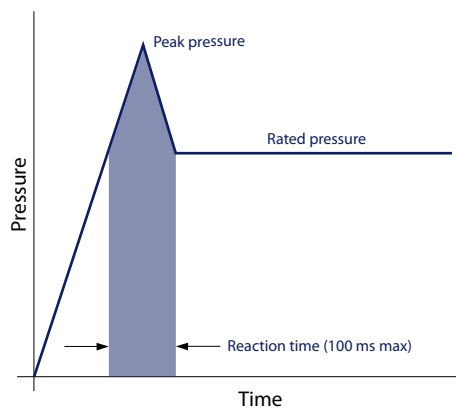



## System Requirements

### Speed

**Maximum speed** is the limit recommended by Danfoss for a particular gear pump when operating at rated pressure. It is the highest speed at which normal life can be expected.

**Minimum speed** is the lowest operating speed limit at which normal life can be expected. The minimum speed increases according to operating pressure increase.

When operating at higher pressures, a higher minimum speed must be maintained, see below:

*Speed versus pressure*

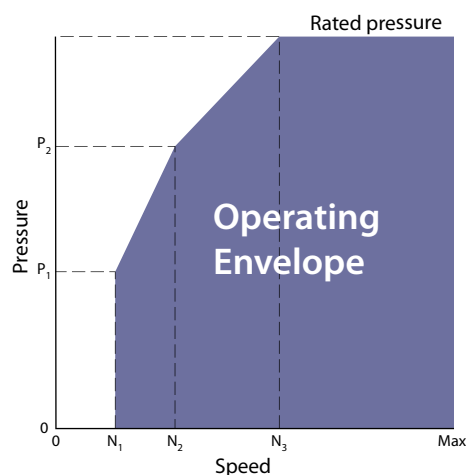

*Operating envelope legend:*

- N<sub>1</sub>** Minimum speed at 100 bar
- N<sub>2</sub>** Minimum speed at 180 bar
- N<sub>3</sub>** Minimum speed at rated pressure

### Hydraulic Fluids

Ratings and data for shhark® gear pumps are guaranteed when the hydraulic system operates with premium hydraulic fluids without containing oxidation, rust, or foam inhibitors.

These fluids have to work with good thermal and hydrolytic stability to prevent wear, erosion, or corrosion of internal components. They include:

- Hydraulic fluids following DIN 51524, part 2 (HLP) and part 3 (HVLP) specifications
- API CD engine oils conforming to SAE J183
- M2C33F or G automatic transmission fluids
- Certain agricultural tractor fluids

**⚠ Caution**

**Use only clean fluid in the gear pumps and hydraulic circuit. Never mix hydraulic fluids.**

## System Requirements

### Temperature and Viscosity

Temperature and viscosity requirements must be concurrently met. Use of petroleum/mineral-based fluids is highly recommended.

**High temperature** limits apply at the inlet port of the pumps. The pumps should run at or below the maximum continuous temperature.

**Minimum (cold start) temperature** relates to the physical properties of component materials.

**Maximum continuous temperature** allowed at which normal life can be expected.

**Peak (intermittent) temperature** is the overheating temperature that is tolerable by the machine for a transient/limited time.

Cold oil, generally, doesn't affect the durability of pumps components. It may affect the ability of oil to flow and transmit power. For this reason, keep the temperature at 16°C [60 °F] above the pour point of the hydraulic fluid.

#### Temperature limits

Minimum (cold start)	Maximum continuous	Peak (intermittent)
-20°C [-4°F]	95°C [203°F]	110°C [230°F]

**Minimum viscosity** occurs only during brief occasions of maximum ambient temperature and severe duty cycle operation. It's the minimum acceptable viscosity to allow normal motor life.

**Maximum viscosity** occurs only during cold start at very low ambient temperatures. It's the upper limit of viscosity that allows the motor to start.

- Size heat exchangers to keep the fluid within these limits
- Test regularly to verify that these temperatures and viscosity limits aren't exceeded
- Keep the fluid viscosity in the recommended viscosity range for maximum unit efficiency and bearing life

#### Fluid viscosity limits, in mm<sup>2</sup>/s [SUS]

Maximum (cold start)	Recommended range	Range for high efficiency	Minimum
1600 [7273]	12-100 [66-456]	20-50 [97-231]	10 [60]

## System Requirements

### Filtration

#### Filters

Use a filter that conforms to Class 22/18/13 of ISO 4406 (or better). It may be on the outlet (pressure filtration) or inlet (return line filtration).

#### Selecting a filter

When selecting a filter, please consider:

- Contaminant ingress rate (determined by factors such as the number of actuators used in the system)
- Generation of contaminants in the system
- Required fluid cleanliness
- Desired maintenance interval
- Filtration requirements of other system components

Measure filter efficiency with a Beta ratio ( $\beta_x$ ).  $\beta_x$  ratio is a measure of filter efficiency defined by ISO 4572. It is the ratio of the number of particles greater than a given diameter (in microns) upstream of the filter to the number of these particles downstream of the filter.

- For suction filtration with controlled reservoir ingress, use a  $\beta_{35-45} = 75$  filter
- For pressure or return filtration, use a filtration with an efficiency of  $\beta_{10} = 75$

The filtration requirements for each system are unique. Evaluate filtration system capacity by monitoring and testing prototypes.

#### Fluid cleanliness level and $\beta_x$ ratio

<b>Fluid cleanliness level (per ISO 4406)</b>	Class 22/18/13 or better
<b><math>\beta_x</math> ratio (suction filtration)</b>	$\beta_{35-45} = 75$ and $\beta_{10} = 2$
<b><math>\beta_x</math> ratio (pressure or return filtration)</b>	$\beta_{10} = 75$
<b>Recommended inlet screen size</b>	100 – 125 $\mu\text{m}$ [0.004 – 0.005 in]

#### Reservoir

The **reservoir** provides clean fluid, dissipates heat, removes entrained air, and allows fluid volume changes associated with fluid expansion and cylinder differential volumes. A correctly sized reservoir accommodates maximum volume changes during all system operating modes. It promotes de-aeration of the fluid as it passes through, and accommodates a fluid dwell-time between 60 and 180 seconds, allowing entrained air to escape.

**Minimum reservoir capacity** depends on the volume required to cool and hold the oil from all retracted cylinders, allowing for expansion due to temperature changes. A fluid volume of 1 to 3 times the pump output flow (per minute) is satisfactory. The minimum reservoir capacity is 125% of the fluid volume.

Install the suction line above the bottom of the reservoir to take advantage of gravity separation and prevent large foreign particles from entering the line. Cover the line with a 100-125 micron screen. The pump should be below the lowest expected fluid level.

Put the return-line below the lowest expected fluid level to allow discharge into the reservoir for maximum dwell and efficient deaeration. A baffle (or baffles) between the return and suction lines promotes deaeration and reduces fluid surges.

## System Requirements

### Line sizing

Choose pipe sizes that accommodate minimum fluid velocity to reduce system noise, pressure drops, and overheating. This maximizes system life and performance.

Design inlet piping that maintains continuous pump inlet pressure above 0.8 bar absolute during normal operation. The line velocity should not exceed the values in the table below:

#### Maximum line speed

Inlet	Outlet	Return
5 m/s [16.4 ft/sec]	2.5 m/s [8.2 ft/sec]	3 m/s [9.8 ft/sec]

Most systems use hydraulic oil containing 10% dissolved air by volume. Under inlet vacuum conditions the oil releases the dissolved air. Moreover, when inlet vacuum is particularly severe, the hydraulic fluid may cavitate, causing adjacent metal surfaces to erode.

#### Warning

**Over-aeration** is the result of air leaks on the inlet side of the pump, and flow-line restrictions.

This problem will not occur if inlet vacuum and rated speed requirements are maintained, reservoir size and location are adequate, adequate pipes size is used, avoiding sharp bends, or elbow fittings causing a reduction of flow line cross-sectional area.

## Pump Drive

Shaft options for shhark® Group 2 gear pump include tapered, tang, splined, or parallel shafts. They are suitable for a wide range of direct and indirect drive applications for radial and thrust loads.

**Plug-in drives**, acceptable only with a splined shaft, can impose severe radial loads when the mating spline is rigidly supported. Increasing spline clearance does not alleviate this condition. Use plug-in drives if the concentricity between the mating spline and pilot diameter is within 0.1 mm [0.004 in]. Lubricate the drive by flooding it with oil. A 3-piece coupling minimizes radial or thrust shaft loads.

#### Pilot cavity

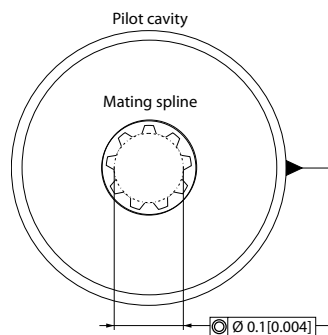

#### Caution

In order to avoid spline shaft damages it is recommended to use carburized and hardened steel couplings with 80-82 HRA surface hardness.

Allowable **radial shaft loads** are a function of the load position, load orientation, and operating pressure of the hydraulic pump. All external shaft loads have an effect on bearing life, and may affect pump performance.

In applications where external shaft loads can't be avoided, minimize the impact on the pump by optimizing the orientation and magnitude of the load. Use a tapered input shaft; don't use splined shafts for belt or gear drive applications. A spring-loaded belt tension-device is recommended for belt drive applications to avoid excessive tension. Avoid thrust loads in either direction. Contact Danfoss if continuously applied external radial or thrust loads occur.

## System Requirements

### Pump Life

Pump life is a function of speed, system pressure, and other system parameters (such as fluid quality and cleanliness).

All Danfoss gear pumps use hydrodynamic journal bearings that have an oil film maintained between the gear/shaft and bearing surfaces at all times. If the oil film is sufficiently sustained through proper system maintenance and operating within recommended limits, long life can be expected.

---

[B<sub>10</sub> life expectancy number is generally associated with rolling element bearings. It does not exist for hydrodynamic bearings.](#)

---

High pressure, resulting from high loads, impacts pump life. When submitting an application for review, provide machine duty cycle data that includes percentages of time at various loads and speeds. We strongly recommend a prototype testing program to verify operating parameters and their impact on life expectancy before finalizing any system design.

### Sound Level

Fluid power systems are inherent generators of noise. As with many high power density devices, noise is an unwanted side effect.

However, there are many techniques available to minimize noise associated with fluid power systems. To apply these methods effectively, it is necessary to understand how the noise is generated and how it reaches the listener. The noise energy can be transmitted away from its source as either fluid borne noise (pressure ripple) or as structure borne noise.

Pressure ripple is the result of the number of pumping elements (gear teeth) delivering oil to the outlet and the pump's ability to gradually change the volume of each pumping element from high to low pressure. In addition, the pressure ripple is affected by the compressibility of the oil as each pumping element discharges into the outlet of the pump. Pressure pulsations will travel along the hydraulic lines at the speed of sound (about 1400 m/s in oil) until affected by a change in the system such as an elbow fitting. Thus the pressure pulsation amplitude varies with overall line length and position.

**Structure borne noise** may be transmitted wherever the pump casing is connected to the rest of the system. The response of one circuit component to excitation depends on its size, form, and manner in which it is mounted or supported. Because of this excitation, a system line may actually have a greater noise level than the pump. To reduce this excitation, use flexible hoses in place of steel plumbing. If steel plumbing must be used, clamping of lines is recommended. To minimize other structure borne noise, use flexible (rubber) mounts.

---

[Contact your Danfoss representative for assistance with system noise control.](#)

---

**Sound Level Graphs**

The sound level graphs show typical sound pressure levels for SHHP2NN and SKP2NN pumps (with SAE A flange and spline shaft) expressed in dB(A) at 1 m [3.28 ft] from the unit.

Data were taken using ISO VG46 petroleum /mineral based fluid at 50°C (viscosity at 28 mm<sup>2</sup>/s [cSt]).

These values are only comparative numbers, since they are obtained in test lab, not in an anechoic chamber.

**Frame size 8,0 sound levels graph**

*Comparison SKP2 versus SHHP2 at 1500 rpm, 50°C*

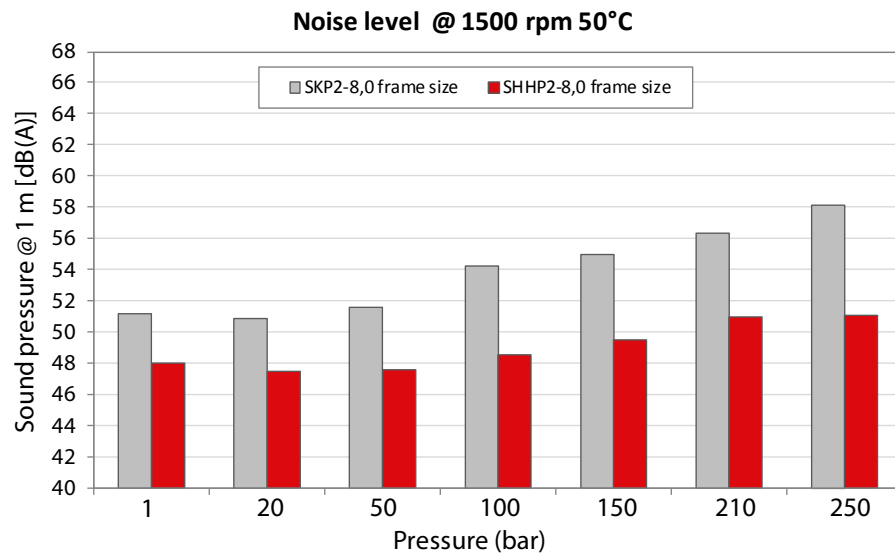

*Comparison SKP2 versus SHHP2 at 3000 rpm, 50°C*

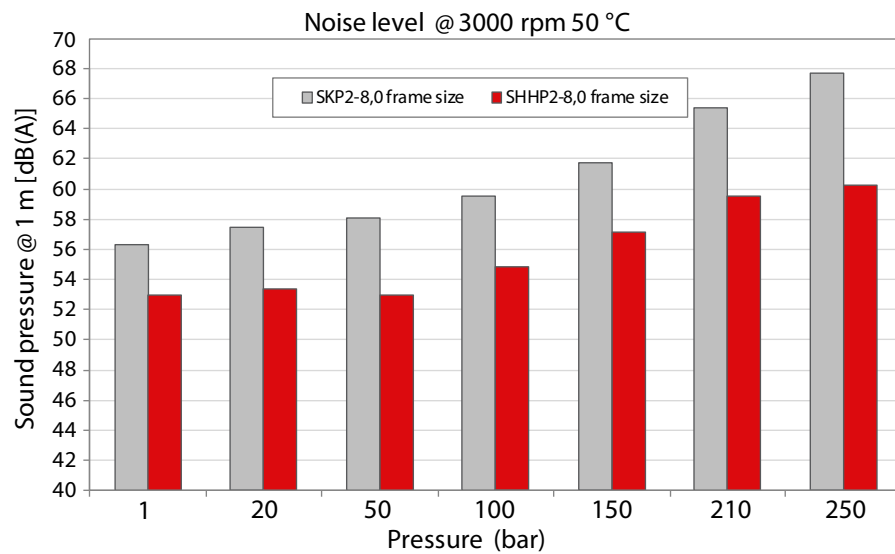

## Sound Level Graphs

### Frame size 011 sound levels graph

Comparison SKP2 versus SHHP2 at 1500 rpm, 50°C

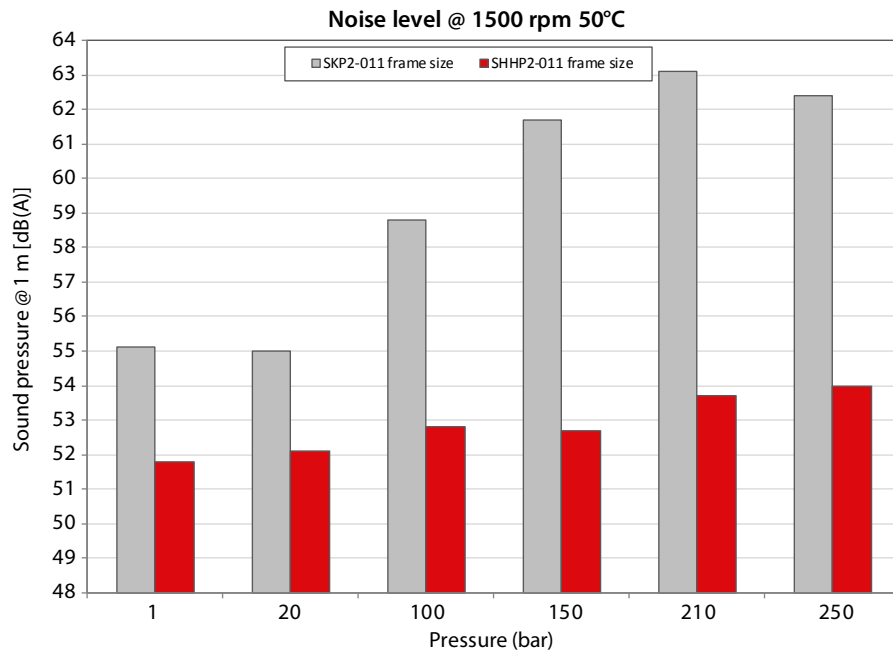

Comparison SKP2 versus SHHP2 at 3000 rpm, 50°C

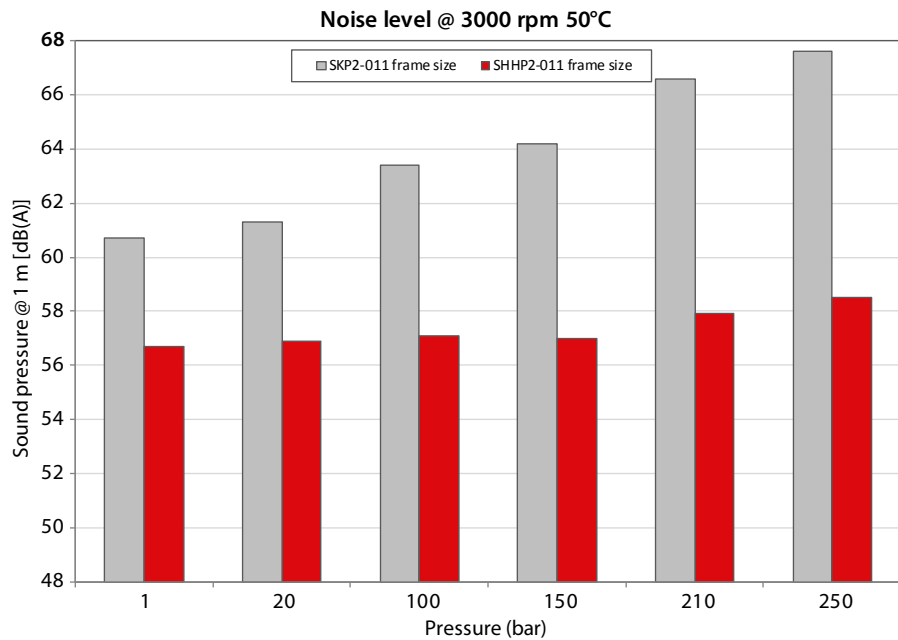

**Sound Level Graphs**

**Frame size 014 sound levels graph**

*Comparison SKP2 versus SHHP2 at 1500 rpm, 50°C*

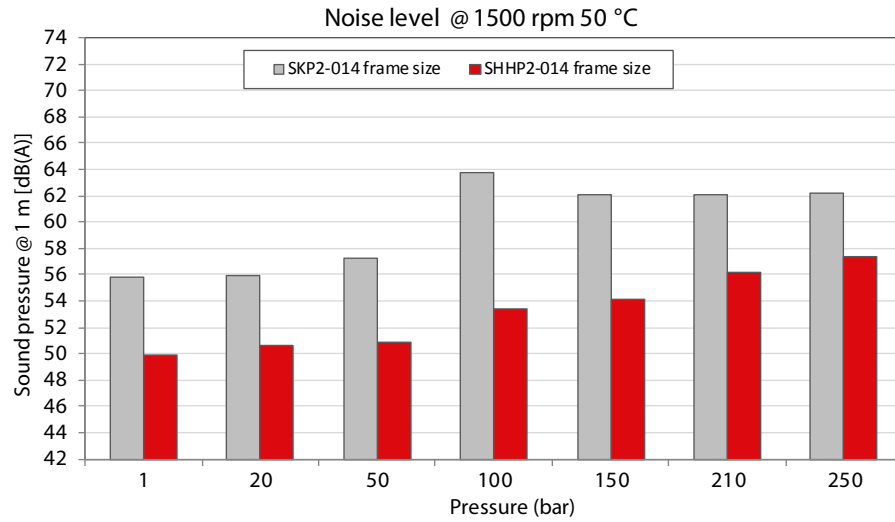

*Comparison SKP2 versus SHHP2 at 3000 rpm, 50°C*

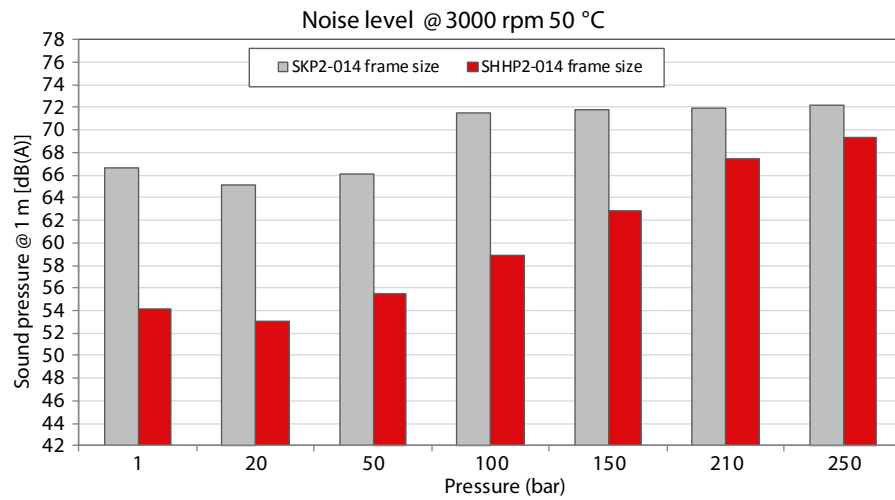



## Sound Level Graphs

### Frame size 017 sound levels graph

Comparison SKP2 versus SHHP2 at 1500 rpm, 50°C

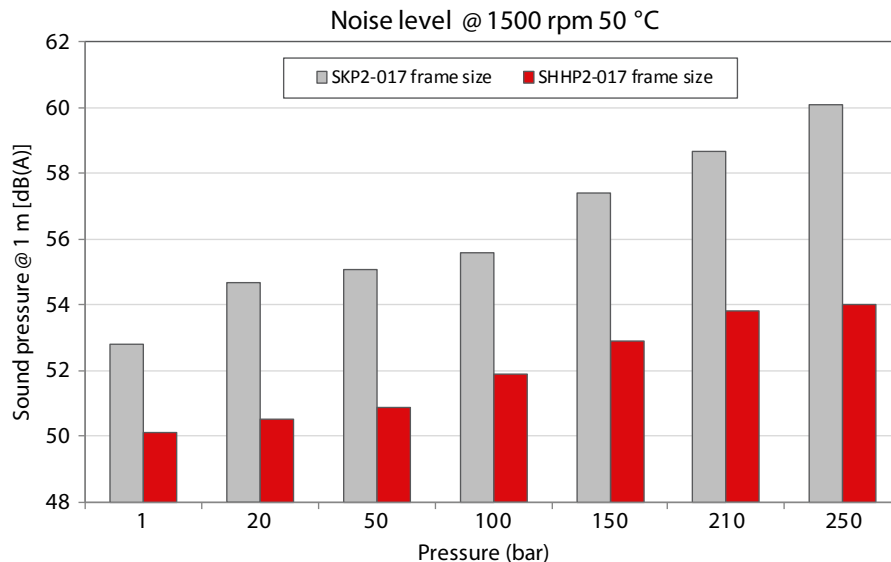

Comparison SKP2 versus SHHP2 at 3000 rpm, 50°C

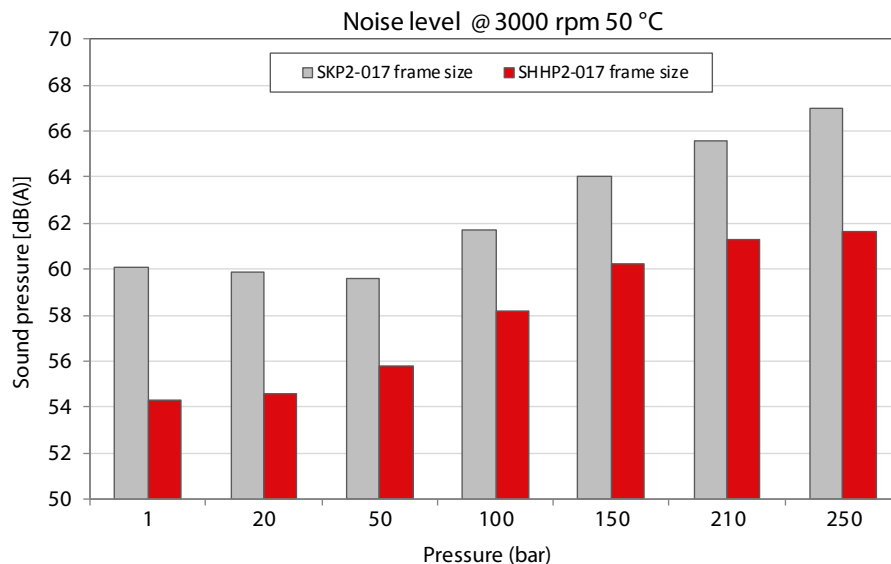

**Sound Level Graphs**

**Frame size 019 sound levels graph**

*Comparison SKP2 versus SHHP2 at 1500 rpm, 50°C*

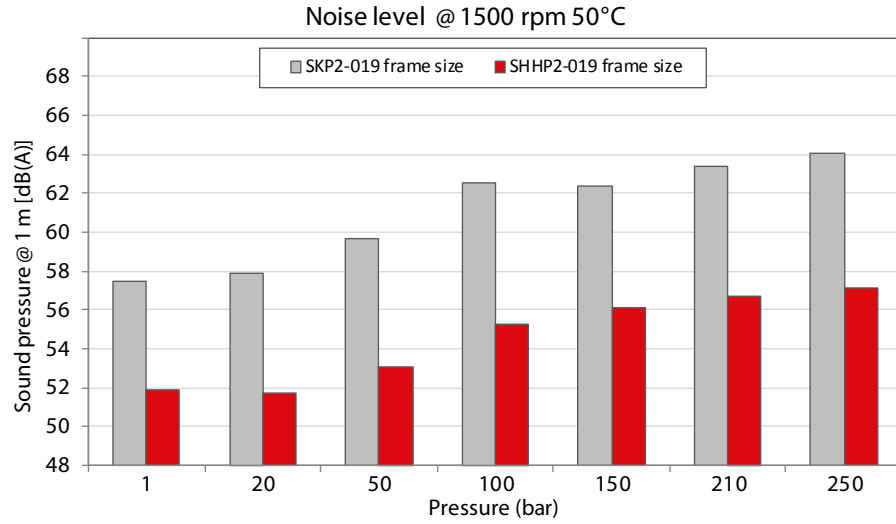

*Comparison SKP2 versus SHHP2 at 3000 rpm, 50°C*

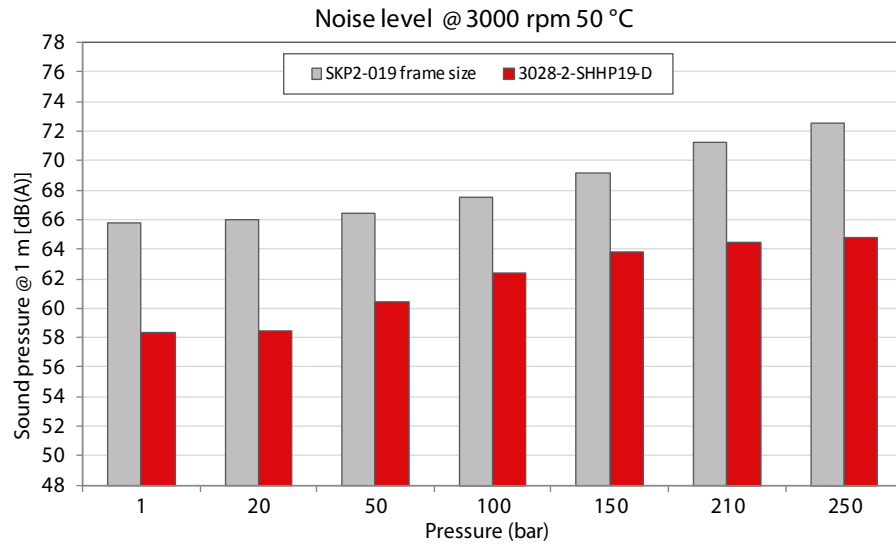

## Sound Level Graphs

### Frame size 022 sound levels graph

Comparison SKP2 versus SHHP2 at 1500 rpm, 50°C

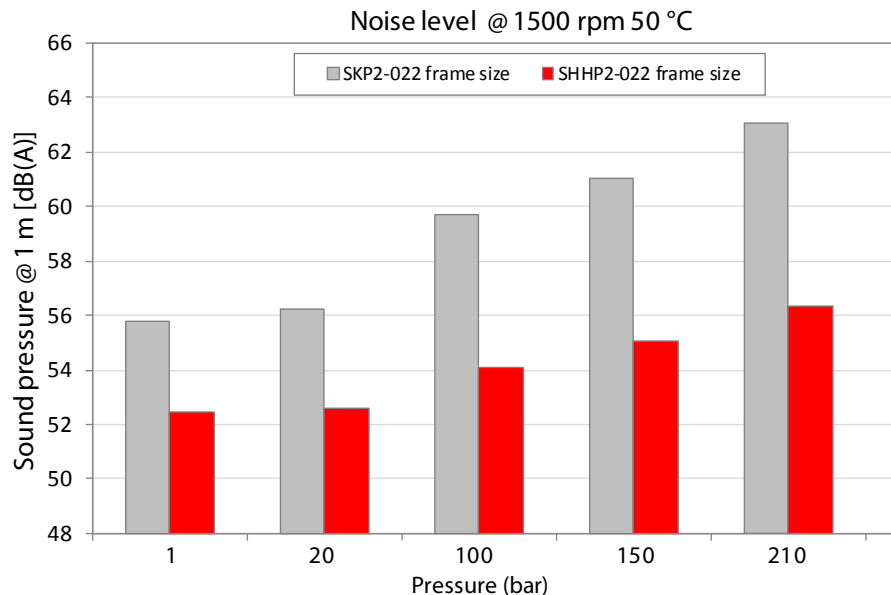

Comparison SKP2 versus SHHP2 at 3000 rpm, 50°C

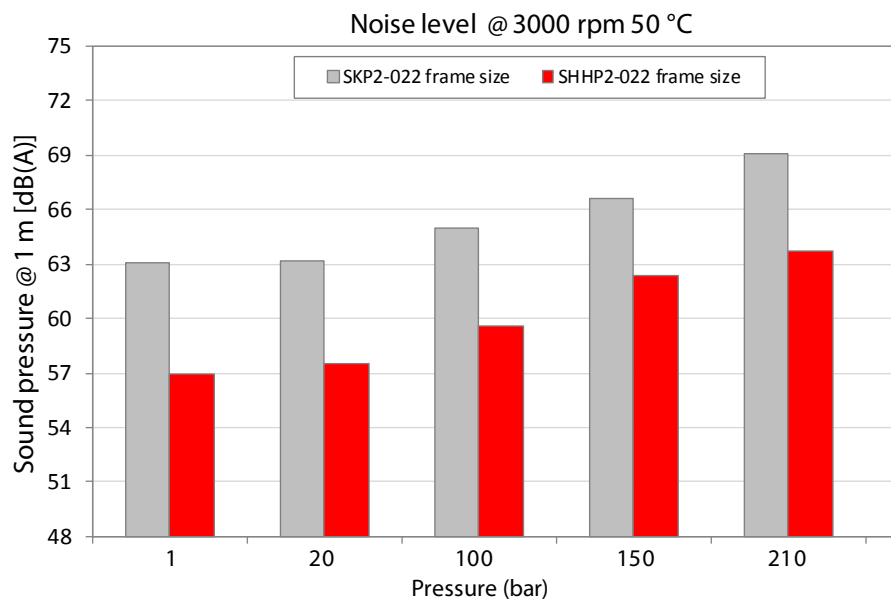

**Sound Level Graphs**

**Frame size 025 sound levels graph**

*Comparison SKP2 versus SHHP2 at 1500 rpm, 50°C*

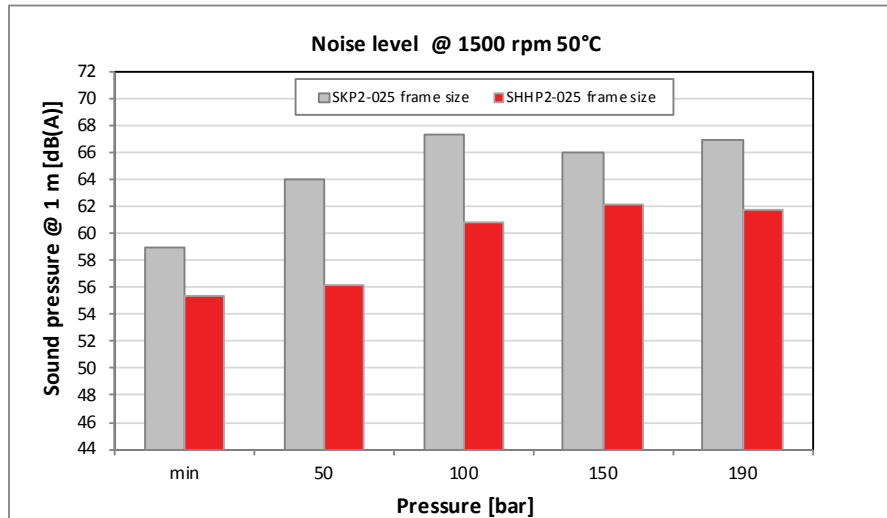

*Comparison SKP2 versus SHHP2 at 3000 rpm, 50°C*

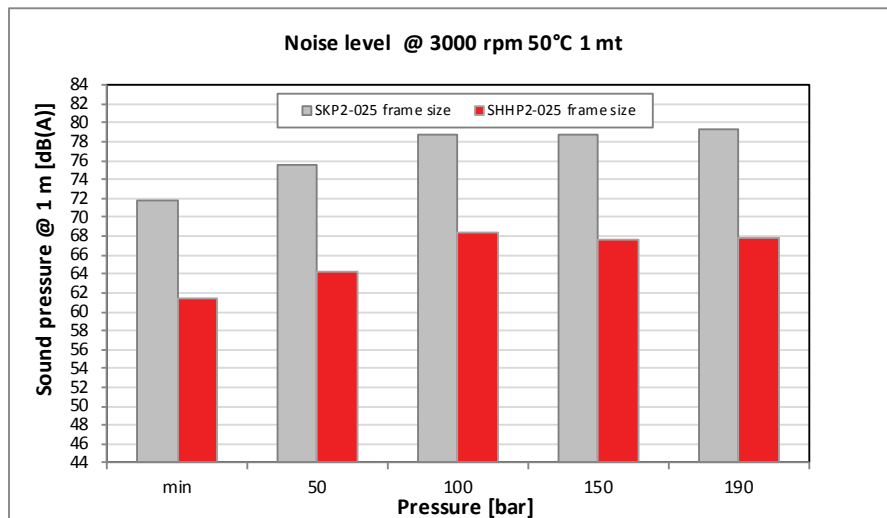

### Pump Performance Graphs

The graphs on the next pages provide typical output flow and input power for shhark® pumps at various working pressures.

Data were taken using ISO VG46 petroleum /mineral based fluid at 50°C (viscosity at 28 mm<sup>2</sup>/s [cSt]).

#### Performance Graphs for Frame Size 8,0 and 011

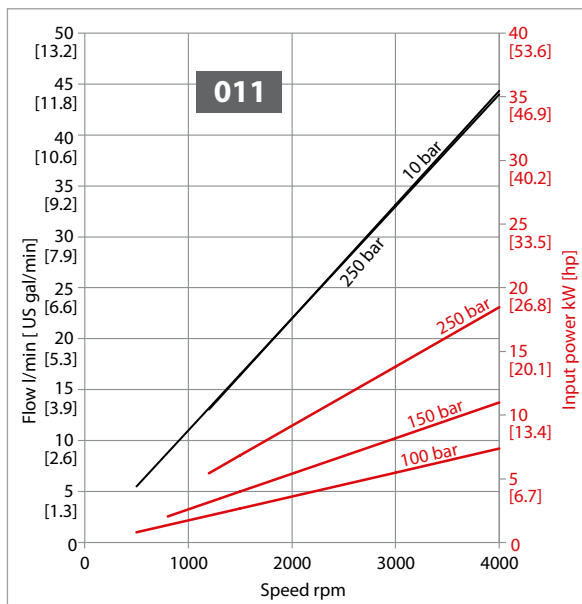
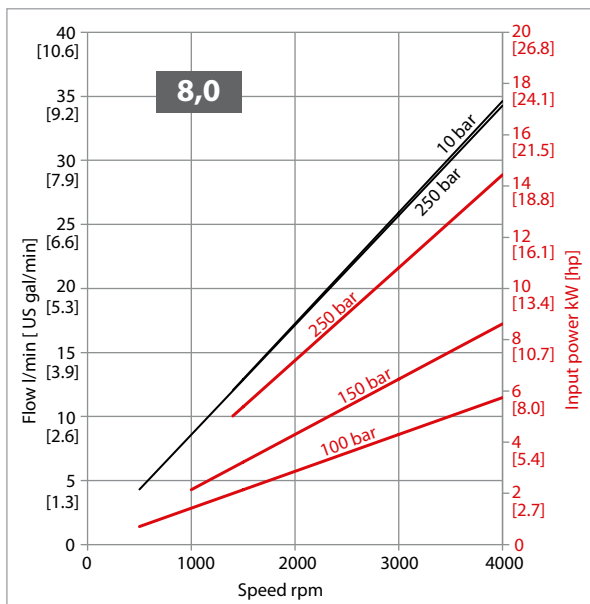

#### Performance Graphs for Frame Size 014 and 017

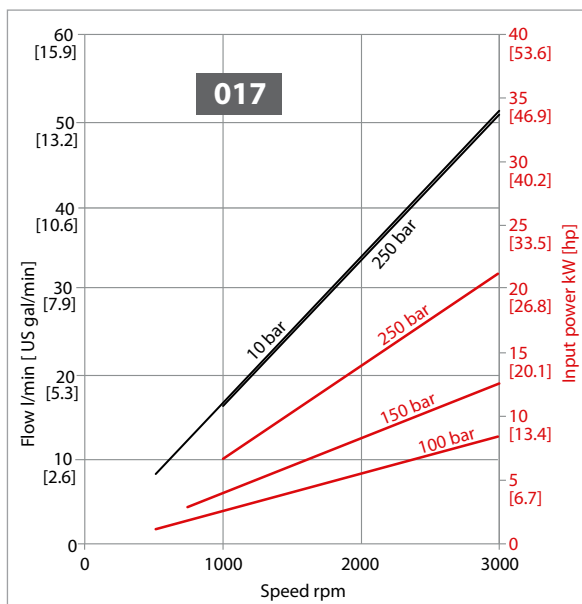
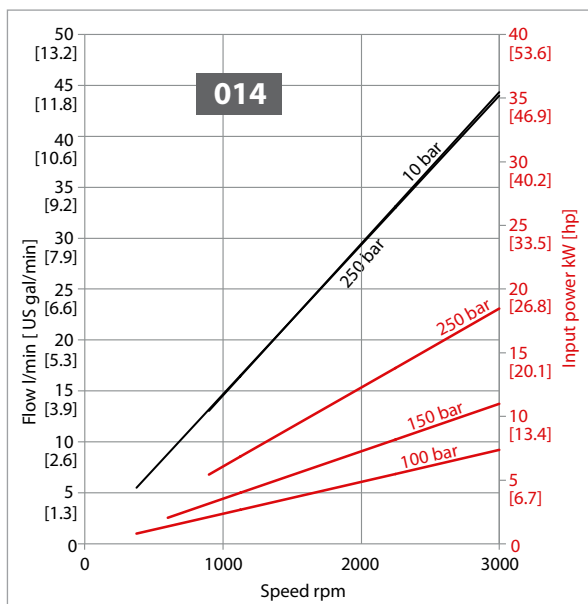

Pump Performance Graphs

Performance Graphs for Frame Size 019, 022 and 025

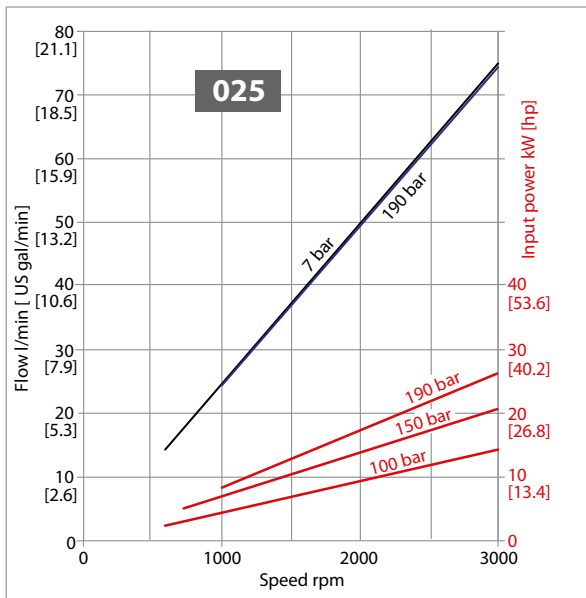
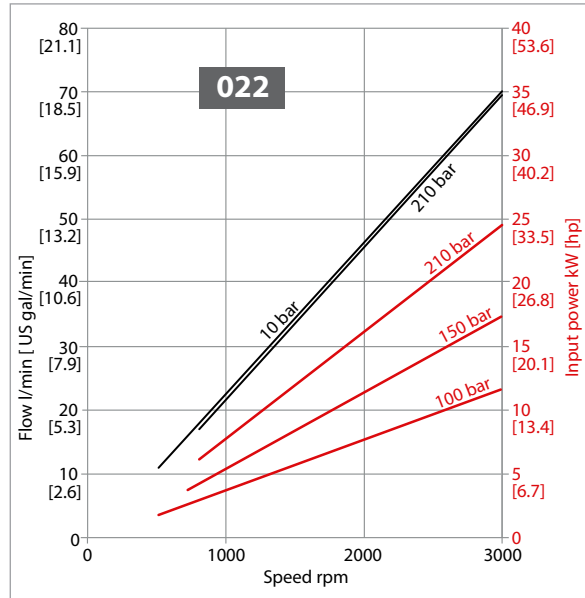
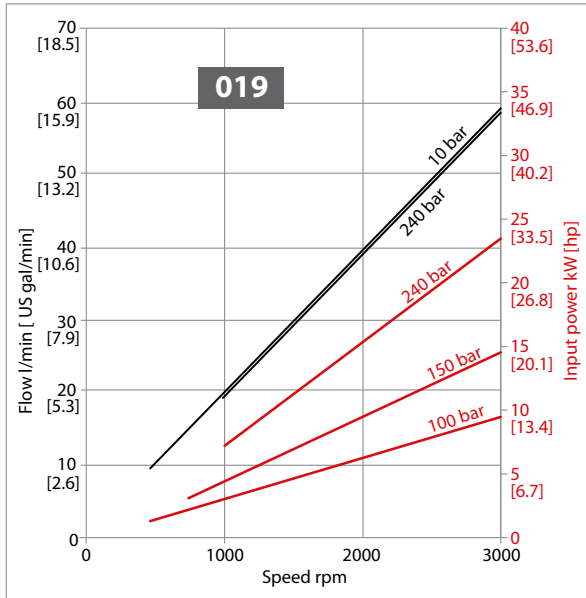

**Product Options**
**Standard Flange, Shaft and Ports Configuration Overview**

Code (single)	Code (tandem)	Flange		Shaft		Ports	
<b>01BA</b>	<b>01BQ</b>	Pilot Ø36.5 mm; 4 holes		Taper 1:8; M12x1.25 with Key 4		European 01, + pattern	
<b>02AA</b>	<b>02AG</b>	Pilot Ø80 mm; 4 holes German PTO		Taper 1:5; M12x1.25 with Key 3		German standard, x pattern	
<b>03CA</b>	Not available	Danfoss 03		Danfoss tang		German standard, x pattern	
<b>04AA</b>	<b>04AG</b>	Pilot Ø50 mm; 2 holes through body German PTO		Taper 1:5; M12x1.25 with Key 3		German standard, x pattern	
<b>05AA</b>	<b>05AG</b>	Pilot Ø50 mm; 2 holes through body German PTO		Taper 1:5; M12x1.25 with Key 3		German standard, x pattern	
<b>06GA</b>	Not available	SAE A pilot Ø82.55 mm; 2 holes		Ø15.875 mm [0.625 in] parallel		Threaded SAE; O- Ring boss	
<b>06SA</b>	<b>06SM</b>	SAE A pilot Ø82.55 mm; 2 holes		Spline SAE J498-9T-16/32DP		Threaded SAE; O- Ring boss	
<b>06SB</b>	<b>06SS</b>	SAE A pilot Ø82.55 mm; 2 holes		Spline SAE J498-11T-16/32D P		Threaded SAE; O- Ring boss	

Other combinations are available upon request.

**Product Options**
**Shaft Options**

Direction is viewed facing the shaft. Group 2 pumps are available with a variety of tang, splined, parallel, and tapered shaft ends. Not all shaft styles are available with all flange styles.

Model code section F



Shaft versus flange availability and torque capability

Shaft		Mounting flange code with maximum torque in N·m [lbf·in]					
Description	Code	01	02	03	04	05	06
Taper 1:5; M12x1.25 with Key 3	AA	–	140 [1239]	–	140 [1239]	140 [1239]	–
Taper 1:8; M12x1.25 with Key 4	BA	150 [1328]	–	–	–	–	–
Spline SAE J498-9T-16/32DP	SA	–	–	–	–	–	90 [796]
Spline SAE J498-11T-16/32DP	SB	–	–	–	–	–	150 [1328]
Parallel 15.875 [0.625]	GA	–	–	–	–	–	80 [708]
Danfoss Tang	CA	–	–	70 [620]	–	–	–

Other shaft options may exist. Contact your Danfoss representative for availability.

**! Caution**

Shaft torque capability may limit allowable pressure. Torque ratings assume no external radial loading. Applied torque must not exceed these limits, regardless of stated pressure parameters. Maximum torque ratings are based on shaft torsional fatigue strength.

The second section torque limit is equal to 70 N·m. Other configuration with higher rated torque are available upon request.



**Product Options**

**Pumps with integral relief valve • SHHP2EN and SHHP2IN**

Group 2 pumps are offered with an optional **integral relief valve** in the rear cover . This valve can have an internal (SHHP2IN) or external (SHHP2EN) drain.

This valve opens directing all flow from the pump outlet to the internal or external drain when the pressure at the outlet reaches the valve setting. This valve can be ordered preset to the pressures shown in the table below. Valve performance curve, rear cover cross-section and schematics are shown below.

*Integral relief valve performance graph*

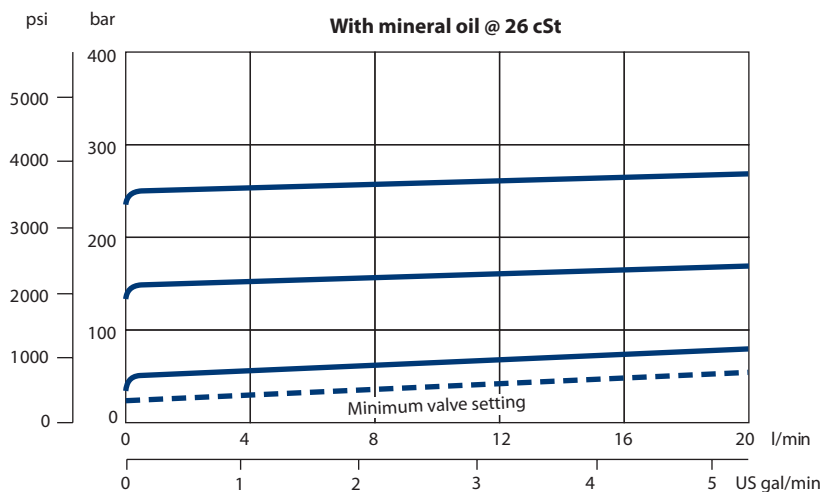

*Integral relief valve cross-section*

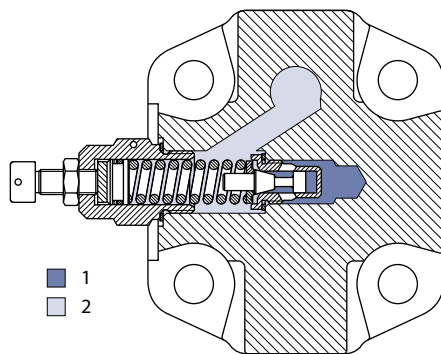

- 1.** Inlet
- 2.** Drain

**⚠ Caution**

When the relief valve is operating in bypass condition, rapid heat generation occurs. If this bypass condition continues, the pump prematurely fails. The reason for this is that it is a rule, not an exception. When frequent operation is required, external drain option (SHHP2EN) must be used.

**Product Options**

**Integral relief valve schematics**

*Integral relief valve with drain: internal (left) / external (right)*

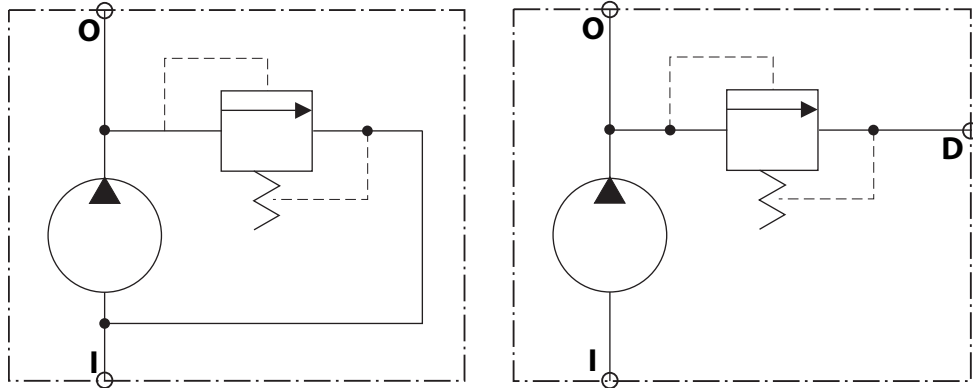

I – inlet  
O – outlet  
D – external drain

**Integral relief valve covers SHHP2EN and SHHP2IN**

*Dimensions (SAE flange); mm [in]*

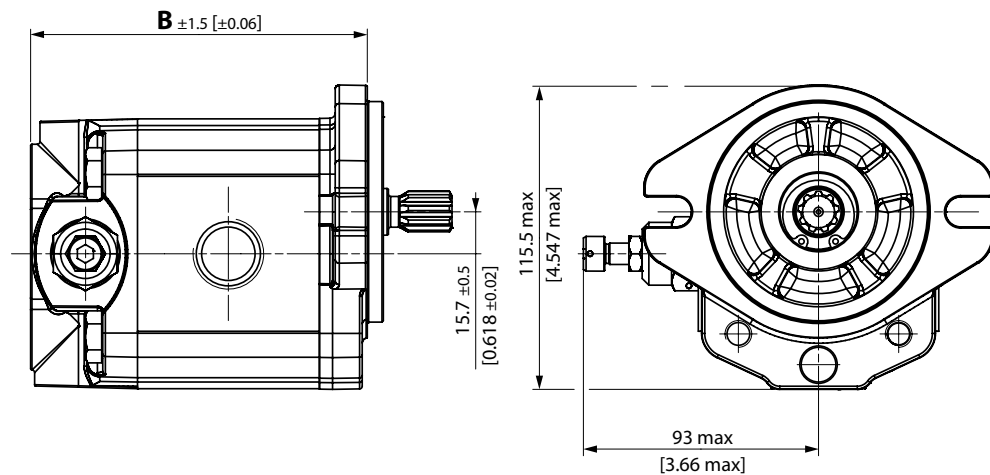

*SHHP2EN/IN dimensions*

Frame size	8,0	011	014	017	019	022
<b>B</b>	117.5 [4.63]	121.5 [4.78]	127.5 [5.02]	131.5 [5.18]	135.5 [5.33]	141.5 [5.57]

## Product Options

### Model Codes for Integral Relief Valve

The tables below detail the various codes for ordering integral relief valves in M section of the model code:



#### A – Family

<b>SHHP2EN</b>	Low Noise Group 2 Pump + External Drain RV*
<b>SHHP2IN</b>	Low Noise Group 2 Pump + Internal Drain RV

\* For this option please contact your Danfoss representative.

#### M1 – integral relief valves variant codes

<b>V</b>	With integral relief valve variant
----------	------------------------------------

#### M2 – Pump speed codes

Code	Pump speed for RV setting	Code	Pump speed for RV setting
<b>A</b>	Not defined		
<b>C</b>	500 min <sup>-1</sup> (rpm)	<b>I</b>	2250 min <sup>-1</sup> (rpm)
<b>E</b>	1000 min <sup>-1</sup> (rpm)	<b>L</b>	2500 min <sup>-1</sup> (rpm)
<b>F</b>	1250 min <sup>-1</sup> (rpm)	<b>M</b>	2800 min <sup>-1</sup> (rpm)
<b>G</b>	1500 min <sup>-1</sup> (rpm)	<b>N</b>	3000 min <sup>-1</sup> (rpm)
<b>K</b>	2000 min <sup>-1</sup> (rpm)	<b>O</b>	3250 min <sup>-1</sup> (rpm)

#### M3 – Pressure setting codes

Code	Pressure setting	Code	Pressure setting
<b>A</b>	No setting		
<b>B</b>	No valve	<b>P</b>	100 bar [1450 psi]
<b>C</b>	18 bar [261 psi]	<b>Q</b>	110 bar [1595 psi]
<b>D</b>	25 bar [363 psi]	<b>R</b>	120 bar [1740 psi]
<b>E</b>	30 bar [435 psi]	<b>S</b>	130 bar [1885 psi]
<b>F</b>	35 bar [508 psi]	<b>T</b>	140 bar [2030 psi]
<b>G</b>	40 bar [580 psi]	<b>U</b>	160 bar [2320 psi]
<b>K</b>	50 bar [725 psi]	<b>V</b>	170 bar [2465 psi]
<b>L</b>	60 bar [870 psi]	<b>W</b>	180 bar [2611 psi]
<b>M</b>	70 bar [1015 psi]	<b>X</b>	210 bar [3046 psi]
<b>N</b>	80 bar [1160 psi]	<b>Y</b>	240 bar [3480 psi]
<b>O</b>	90 bar [1305 psi]	<b>Z</b>	250 bar [3626 psi]

### Caution

For pressures higher than 210 bar or lower than 40 bar apply to your Danfoss representative.

**Dimensions and Data**
**SHHP2NN – 01BA**

Standard porting for 01BA; mm [in]

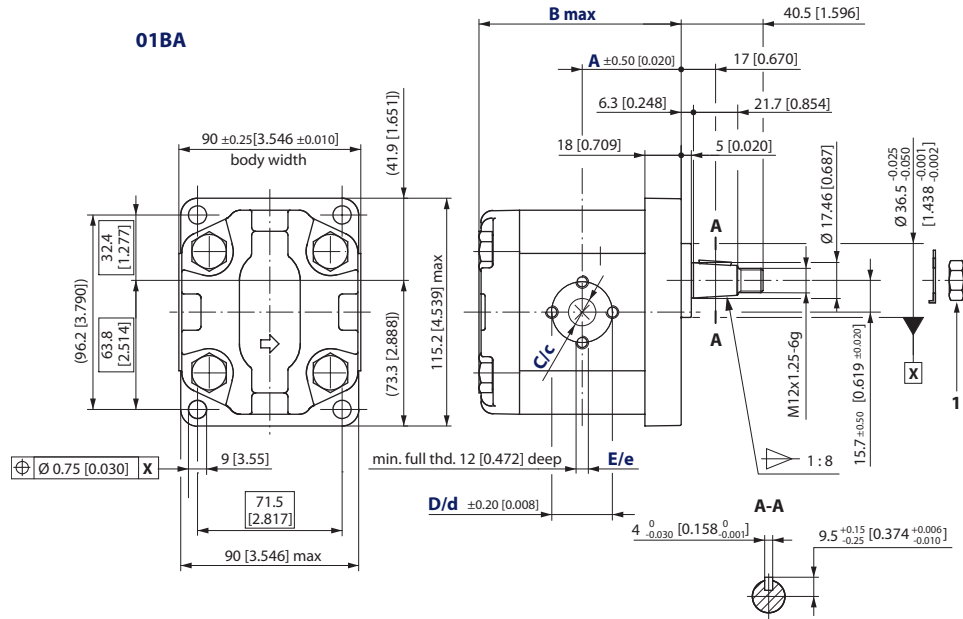

1. Nut and washer supplied with pump; recommended tightening torque 45-55 N•m.

SHHP2NN – 01BA dimensions

Frame size	6,0	8,0	011	014	017	019	022	025
Dimension	A	45 [1.772]	45 [1.772]	49 [1.929]	52 [2.047]	52 [2.047]	56 [2.205]	59 [2.323]
	B	93 [3.681]	97.5 [3.839]	101.5 [3.996]	107.5 [4.232]	111.5 [4.390]	115.5 [4.574]	121.5 [4.783]
Inlet	C	13.5 [0.531]			20 [0.787]			
	D	30 [1.181]			40 [1.575]			
	E	M6			M8			
Outlet	c	13.5 [0.531]						
	d	30 [1.181]						
	e	M6						

Model code example, maximum shaft torque

Flange/drive gear	Model code example	Maximum shaft torque
01BA	SHHP2NN/8,0LN01BAP1C3C3NNNN/NNNN	150 N•m [1328 lbf•in]

For further details on ordering, see the Model Code section.

**Dimensions and Data**

**SHHP2NN – 02AA**

Standard porting for 02AA; mm [in]

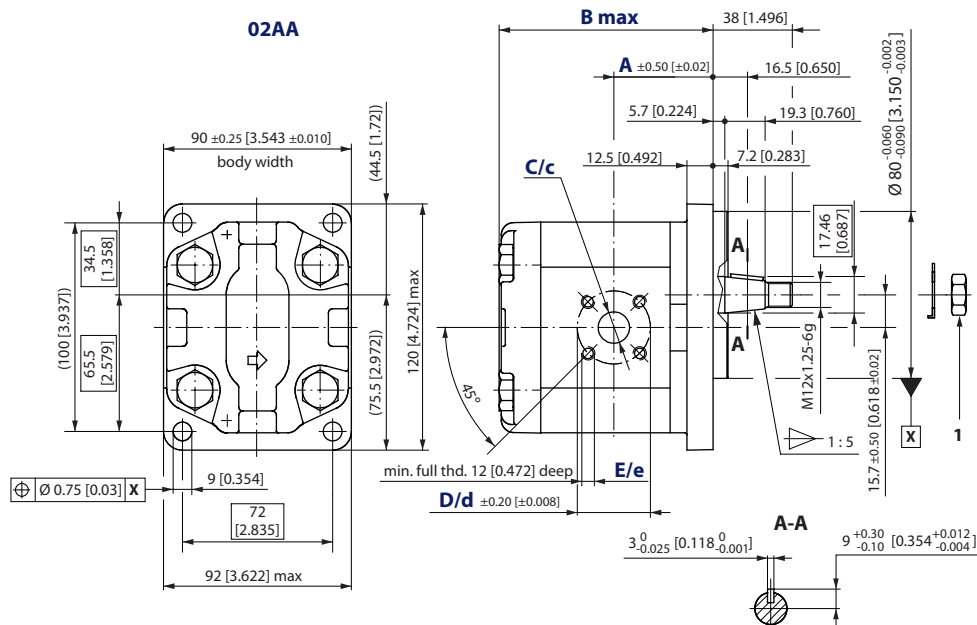

1. Nut and washer supplied with pump; recommended tightening torque 45-55 N•m.

SHHP2NN – 02AA dimensions

Frame size		6,0	8,0	011	014	017	019	022	025
Dimension	A	41.1 [1.618]	43.1 [1.697]	47.5 [1.870]	47.5 [1.870]	47.5 [1.870]	47.5 [1.870]	55 [2.165]	94.5 [2.539]
	B	96 [3.780]	100 [3.937]	104 [4.094]	110 [4.331]	114 [4.488]	118 [4.646]	124 [4.882]	128 [5.039]
Inlet	C	20 [0.787]							
	D	40 [1.575]							
	E	M6							
Outlet	c	15 [0.591]							
	d	35 [1.378]							
	e	M6							

Model code example, maximum shaft torque

Flange/drive gear	Model code example	Maximum shaft torque
02AA	SHHP2NN/017RN02AAP1B7B5NNNN/NNNN	140 N•m [1239 lbf•in]

For further details on ordering, see the Model Code section.

**Dimensions and Data**
**SHHP2NN – 03CA**

Standard porting for 03CA; mm [in]

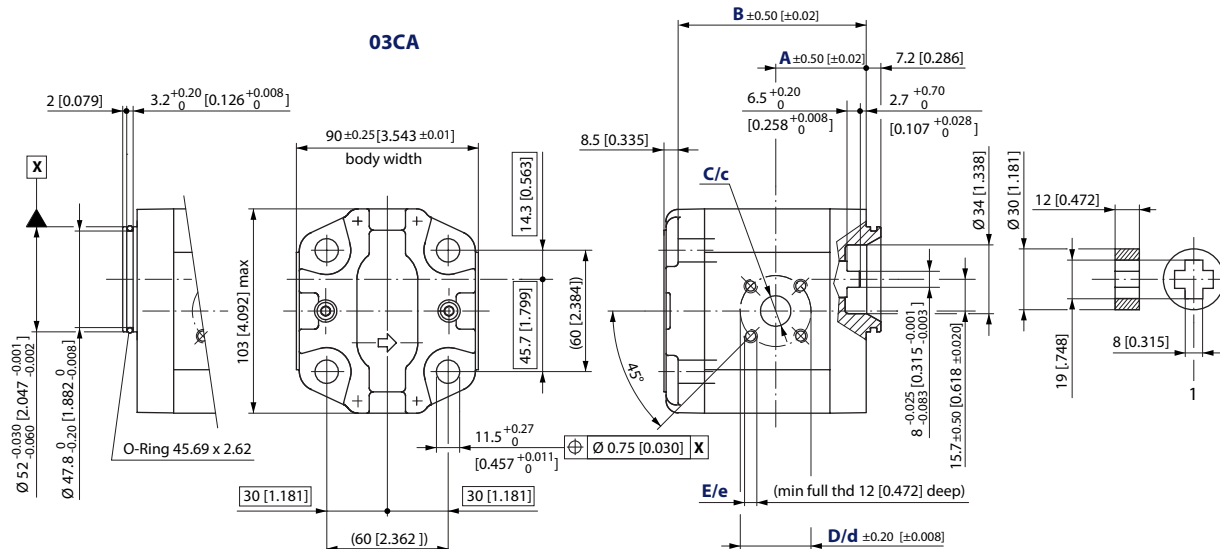
**1. Coupling supplied with pump**
**SHHP2NN – 03CA dimensions**

Frame size		6,0	8,0	011	014	017	019	022	025
Dimension	A	38.6 [1.520]	40.6 [1.598]	45 [1.772]				52.5 [2.067]	62 [2.441]
	B	85 [3.364]	89 [3.503]	93 [3.661]	99 [3.897]	103 [4.055]	107 [4.212]	113 [4.448]	117 [4.606]
Inlet	C	20 [0.787]							
	D	40 [1.575]							
	E	M6							
Outlet	c	15 [0.591]							
	d	35 [1.378]							
	e	M6							

**Model code example, maximum shaft torque**

Flange/drive gear	Model code example	Maximum shaft torque
03CA	SHHP2NN/014RN03CAP3B7B5NNNN/NNNNN	70 N•m [620 lbf•in]

For further details on ordering, see the Model Code section.

## Dimensions and Data

### SHHP2NN – 04/05AA

Standard porting for 04/05AA; mm [in]

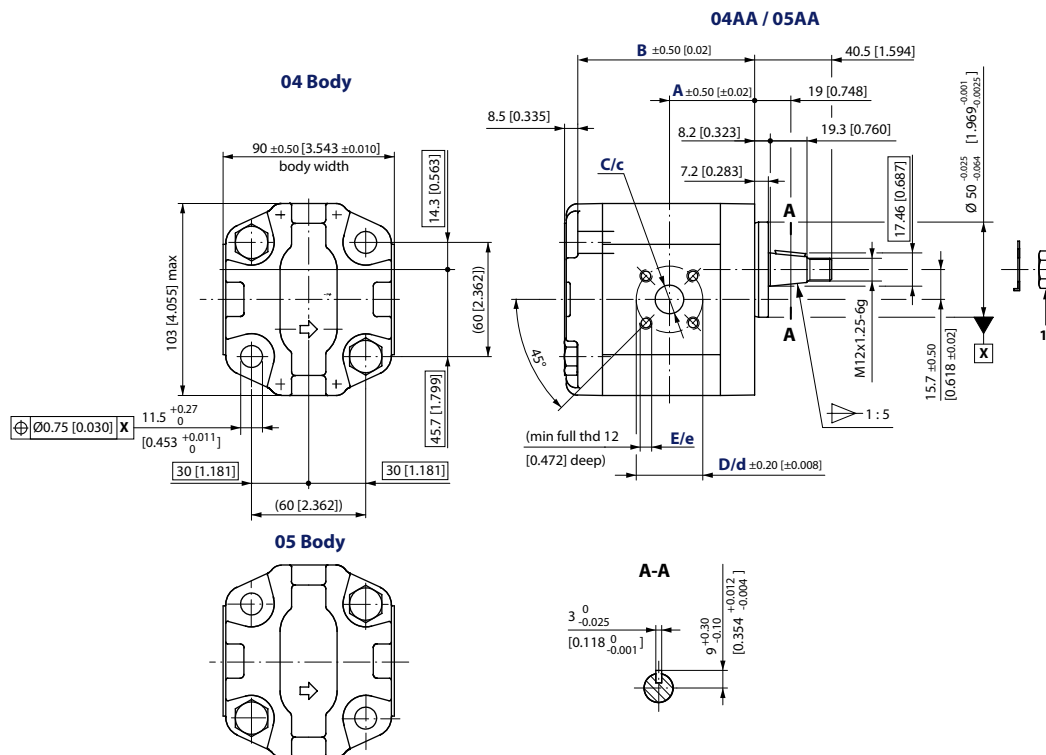

1. Nut and washer supplied with pump; recommended tightening torque 45-55 N•m.

SHHP2NN – 04/05AA dimensions

Frame size	6,0	8,0	011	014	017	019	022	025
Dimension	A	38.6 [1.520]	40.6 [1.598]	45 [1.772]			52.5 [2.067]	62 [2.441]
	B	85 [3.364]	89 [3.503]	93 [3.661]	99 [3.897]	103 [4.055]	107 [4.212]	113 [4.448]
Inlet	C	20 [0.787]						
	D	40 [1.575]						
	E	M6						
Outlet	c	15 [0.591]						
	d	35 [1.378]						
	e	M6						

Model code example, maximum shaft torque

Flange/drive gear	Model code example	Maximum shaft torque
04AA	SHHP2NN/8,0LN04AAP1B7B5NNNN/NNNNN	140 N•m [1239 lbf•in]
05AA	SHHP2NN/014RN05AAP1B7B5NNNN/NNNNN	

For further details on ordering, see the Model Code section.





**Dimensions and Data**
**SHHP2NN – 06SA..BxBxYY../.....**

Standard porting 06SA..Bx.. offset from center of the body; mm [in]

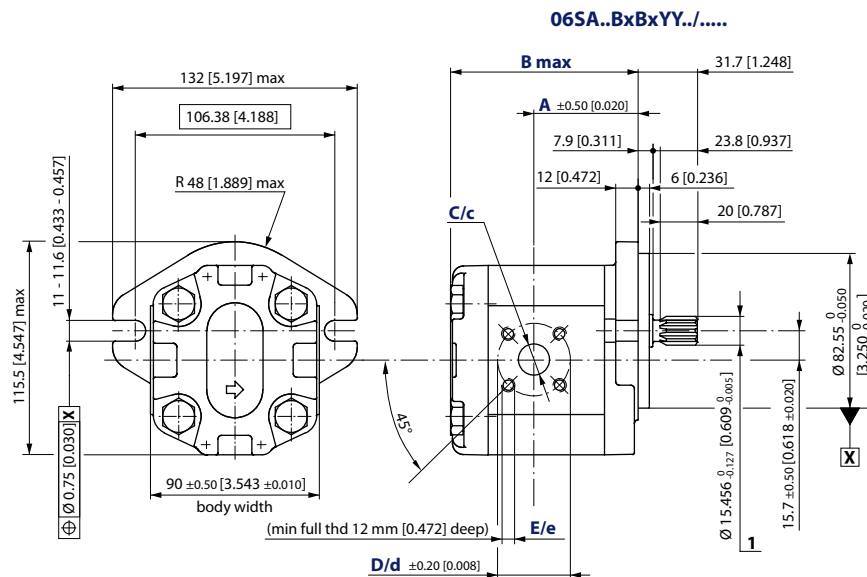

- Splined: SAE J498-9T-16/32DP; Flat root side fit (circular tooth thickness 0.127 mm [0.005] less than standard class 1 fit)

**SHHP2NN – 06SA..BxBxYY../..... dimensions**

Frame size	6,0	8,0	011	014	017	019	022	025	
Dimension	A	51.4 [2.023]	53.4 [2.102]	53.0 [2.087]	59.0 [2.322]	63.0 [2.480]	65.5 [2.579]	67.0 [2.637]	60.0 [2.326]
	B	93.5 [3.681]	97.5 [3.839]	101.5 [3.996]	107.5 [4.232]	111.5 [4.390]	115.5 [4.547]	121.5 [4.783]	125.5 [4.941]
Inlet	C	20 [0.787]							
	D	40 [1.575]							
	E	M6							
Outlet	c	15 [0.591]							
	d	35 [1.378]							
	e	M6							

**Model code example, maximum shaft torque**

Flange/drive gear	Model code example	Maximum shaft torque
06SA..BxBxYY../.....	SHHP2NN/019RN06SAP1B7B5YYNN/NNNNN	90 Nm [796 lbf in]

For further details on ordering, see the Model Code section.

### Products we offer:

- DCV directional control valves
- Electric converters
- Electric machines
- Electric motors
- Gear motors
- Gear pumps
- Hydrostatic motors
- Hydrostatic pumps
- Orbital motors
- PLUS+1® controllers
- PLUS+1® displays
- PLUS+1® joysticks and pedals
- PLUS+1® operator interfaces
- PLUS+1® sensors
- PLUS+1® software
- PLUS+1® software services, support and training
- Position controls and sensors
- PVG proportional valves
- Steering components and systems
- Telematics

**Danfoss Power Solutions** is a global manufacturer and supplier of high-quality hydraulic and electric components. We specialize in providing state-of-the-art technology and solutions that excel in the harsh operating conditions of the mobile off-highway market as well as the marine sector. Building on our extensive applications expertise, we work closely with you to ensure exceptional performance for a broad range of applications. We help you and other customers around the world speed up system development, reduce costs and bring vehicles and vessels to market faster.

Danfoss Power Solutions – your strongest partner in mobile hydraulics and mobile electrification.

### Go to [www.danfoss.com](http://www.danfoss.com) for further product information.

We offer you expert worldwide support for ensuring the best possible solutions for outstanding performance. And with an extensive network of Global Service Partners, we also provide you with comprehensive global service for all of our components.

### Hydro-Gear

[www.hydro-gear.com](http://www.hydro-gear.com)

### Daikin-Sauer-Danfoss

[www.daikin-sauer-danfoss.com](http://www.daikin-sauer-danfoss.com)

Local address:

**Danfoss  
Power Solutions (US) Company**  
2800 East 13th Street  
Ames, IA 50010, USA  
Phone: +1 515 239 6000

**Danfoss  
Power Solutions GmbH & Co. OHG**  
Krokamp 35  
D-24539 Neumünster, Germany  
Phone: +49 4321 871 0

**Danfoss  
Power Solutions ApS**  
Nordborgvej 81  
DK-6430 Nordborg, Denmark  
Phone: +45 7488 2222

**Danfoss  
Power Solutions Trading  
(Shanghai) Co., Ltd.**  
Building #22, No. 1000 Jin Hai Rd  
Jin Qiao, Pudong New District  
Shanghai, China 201206  
Phone: +86 21 2080 6201

Danfoss can accept no responsibility for possible errors in catalogues, brochures and other printed material. Danfoss reserves the right to alter its products without notice. This also applies to products already on order provided that such alterations can be made without subsequent changes being necessary in specifications already agreed. All trademarks in this material are property of the respective companies. Danfoss and the Danfoss logotype are trademarks of Danfoss A/S. All rights reserved.